

# HANDBOOK



**WORLD  
RUGBY™**

**Copyright © World Rugby 2017**

All rights reserved. The reproduction, distribution or transmission of all or part of the work, whether by photocopying or storing in any medium by electronic means or otherwise, without the written permission of World Rugby (application for which should be addressed to World Rugby), is prohibited.

**Published by World Rugby 2017**



# HANDBOOK

AS FRAMED BY  
WORLD RUGBY

---

**CLICK HERE TO DOWNLOAD THE FULL HANDBOOK**

**Click here to download Section 1**

<b>SECTION 1</b>	<b>WORLD RUGBY</b>	<b>7</b>
	Contents	9
	Council	11
	Executive Committee	12
	Committees	12
	Audit & Risk Committee	12
	Regional Committee	12
	Regulations Committee	13
	Rugby Committee	13
	Anti-doping Advisory Committee	13
	Budget Advisory Committee	14
	Medical Advisory Committee	14
	Women's Advisory Committee	14
	Designated Members for Clarifications in Law	14
	Judicial Panel/Appeals Panel Chairman	14
	World Rugby Membership	
	Unions in Membership	15
	Associate Members	19
	Regional Associations	20
	Contacts	21

**Click here to download Section 2**

<b>SECTION 2</b>	<b>Bye-Laws</b>	<b>23</b>
	1. Definitions	27
	2. Management and Control	31
	3. Objectives and Functions of World Rugby	33
	4. Participation in the Game	35
	5. Laws of the Game	37
	6. World Rugby	39
	7. Binding Agreement	41
	8. General Assembly	43
	9. The Council	45
	10. The Executive Committee	55

11. Standing Committees	61
12. Emergency Decisions	65
13. Other Committees	67
14. Membership	69
15. Interpretation	71

**Click here to download Section 3**

<b>SECTION 3</b>	<b>Regulations Relating to the Game</b>	73
	Contents	75
<a href="#">Click here to download this Regulation</a>	1. Definitions	77
<a href="#">Click here to download this Regulation</a>	2. Compliance with Regulations	83
<a href="#">Click here to download this Regulation</a>	3. Domestic Regulations	87
<a href="#">Click here to download this Regulation</a>	4. Player Status, Player Contracts and Player Movement	89
<a href="#">Click here to download this Regulation</a>	5. Agents	121
<a href="#">Click here to download this Regulation</a>	6. Anti-Corruption and Betting	123
<a href="#">Click here to download this Regulation</a>	7. Appearances, Communications, Advertising and Sponsorship	149
<a href="#">Click here to download this Regulation</a>	8. Eligibility to Play for National Representative Teams	151
<a href="#">Click here to download this Regulation</a>	9. Availability of Players	175
<a href="#">Click here to download this Regulation</a>	10. Medical	197
<a href="#">Click here to download this Regulation</a>	11. Advertising Within the Playing Enclosure	201
<a href="#">Click here to download this Regulation</a>	12. Provisions Relating to Players Dress	213
<a href="#">Click here to download this Regulation</a>	13. Broadcasting Rights	255
<a href="#">Click here to download this Regulation</a>	14. Ownership of Clubs	257
<a href="#">Click here to download this Regulation</a>	15. International Matches	259
<a href="#">Click here to download this Regulation</a>	16. Organisation of International Matches; International Tournaments; International Tours	265

Click here to download this Regulation	17. Discipline – Foul Play	269
Click here to download this Regulation	18. Disciplinary and Judicial Matters	323
Click here to download this Regulation	19. Mediation	341
Click here to download this Regulation	20. Misconduct and Code of Conduct	343
	21. Anti-Doping	357
	Schedule 1. Doping Control Procedural Guidelines	455
	Schedule 2. WADA Prohibited List	477
	Schedule 3(a). WADA International Standard for Therapeutic Use Exemptions (TUE)	487
Click here to download this Regulation	Schedule 3(b). World Rugby TUE Application Form	501
	Schedule 4. Acknowledgements and Agreement Form	503
	Schedule 5. Player Information Notice–Data Privacy	505
Click here to download this Regulation	22. Artificial Playing Surfaces	509
Click here to download this Regulation	23. Insurance	517
Click here to download this Regulation	24. Matters Not Provided For	521

**Click here to download Section 4**

<b>SECTION 4</b>	<b>General Regulations of World Rugby</b>	523
	Contents	525
	General Regulations	527

**Click here to download Section 5**

<b>SECTION 5</b>	<b>World Rugby Tours Agreement</b>	531
	Contents	533
	Tours Agreement	535



**WORLD  
RUGBY™**

# SECTION 1

**WORLD RUGBY**





## SECTION 1      **WORLD RUGBY**

Council	11
Executive Committee	12
Committees	12
Audit & Risk Committee	12
Regional Committee	12
Regulations Committee	13
Rugby Committee	13
Anti-doping Advisory Committee	13
Budget Advisory Committee	14
Medical Advisory Committee	14
Women’s Advisory Committee	14
Designated Members for Clarifications in Law	14
Judicial Panel/Appeals Panel Chairman	14
World Rugby Membership	15
Unions in Membership	15
Associate Members	18
Regional Associations	19
Contacts	20



## COUNCIL

<b>Chairman</b>	Bill Beaumont
<b>Argentina</b>	Agustín Pichot ( <i>Vice-Chairman</i> ) Carlos Araujo
<b>Scotland</b>	John Jeffrey Mark Dodson
<b>Ireland</b>	Pat Whelan Dr John O'Driscoll
<b>Wales</b>	Gareth Davies Anthony Buchanan
<b>England</b>	Jonathan Webb Ian Ritchie
<b>France</b>	Pierre Camou Jacques Laurans
<b>Australia</b>	Dr Brett Robinson Bill Pulver
<b>New Zealand</b>	Mark Robinson Steve Tew
<b>South Africa</b>	Mark Alexander Jurie Roux
<b>Canada</b>	Dr Pat Parfrey
<b>Italy</b>	Alfredo Gavazzi TBC
<b>Japan</b>	Dr Ichiro Kono
<b>Georgia</b>	George Nijaradze
<b>Romania</b>	Haralambie Dumitras
<b>USA</b>	Bob Latham
<b>Asia Rugby</b>	Trevor Gregory
<b>Oceania Rugby</b>	Richard Sapias
<b>Rugby Africa</b>	Abdelaziz Bougja
<b>Rugby Americas North</b>	Dennis Dwyer
<b>Rugby Europe</b>	Octavian Morariu
<b>Sudamérica Rugby</b>	Marcelo Rodriguez

## EXECUTIVE COMMITTEE

<b>Members</b>	<b>Bill Beaumont (<i>Chairman</i>)</b>
	Agustín Pichot ( <i>Vice-Chairman</i> )
	Pierre Camou
	Gareth Davies
	John Jeffrey
	Bob Latham
	Dr Brett Robinson
	Mark Robinson
	Pat Whelan
	Lord Mervyn Davies
	Wendy Luhabe
	Brett Gosper

## AUDIT & RISK COMMITTEE

<b>Members</b>	<b>Jacques Laurans (<i>Chairman</i>)</b>
	Carlos Araujo
	Abdelaziz Bougja
	Mark Dodson
	Trevor Gregory
	Jurie Roux
	Steve Tew

## REGIONAL COMMITTEE

<b>Members</b>	<b>Octavian Morariu (<i>Chairman</i>)</b>
	Abdelaziz Bougja
	Dennis Dwyer
	Trevor Gregory
	Marcelo Rodriguez
	Richard Sapias

## REGULATIONS COMMITTEE

**Members**            **Bob Latham (*Chairman*)**

Pierre Camou  
Porfirio Carreras  
Gareth Davies  
Bill Pulver  
Nino Sacca  
Ian Ritchie  
Steve Tew

## RUGBY COMMITTEE

**Members**            **John Jeffrey (*Chairman*)**

Anthony Buchanan  
Haralambie Dumitras  
Dr Brett Robinson  
Mark Robinson  
Nick Mallett  
*Player Representatives:*  
Rachael Burford  
Richie McCaw  
Paul O'Connell

## ANTI-DOPING ADVISORY COMMITTEE

**Members**            **Dr Brett Robinson (*Chairman*)**

Dr Felipe Contepomi  
Dr Daniel Eichner  
Associate Professor David Gerrard  
Dr Audrey Kinahan  
Graeme Mew  
Dr Margo Mountjoy  
Gregor Nicholson  
Christopher Quinlan QC

### BUDGET ADVISORY COMMITTEE

**Members**            **Jurie Roux (*Chairman*)**

Pierre Camou

Bob Latham

Mark Robinson

### MEDICAL ADVISORY COMMITTEE

**Members**            **Dr John O’Driscoll (*Chairman*)**

Dr Ichiro Kono

Dr Pat Parfrey

Dr Martin Raftery

Dr Brett Robinson

Dr Jonathan Webb

### WOMEN’S ADVISORY COMMITTEE

**Members**            **Bill Pulver (*Chairman*)**

Rachael Burford

Emilie Bydwell

Wang Shao-Ing

### DESIGNATED MEMBERS FOR CLARIFICATIONS IN LAW

**Members**            **John Jeffrey (*Chairman*)**

Dr John O’ Driscoll

Mark Robinson

Nick Mallet

*Player Representatives:*

Rachael Burford

Richie McCaw

Paul O’Connell

### JUDICIAL PANEL

Christopher Quinlan QC (*Chairman*)

### APPEALS PANEL CHAIRMAN

Bill Beaumont (*Chairman*)

## UNIONS IN MEMBERSHIP

<i>Country</i>	<i>Union/Federation</i>	<i>Year of Entry</i>
<b>Scotland</b>	Scottish Rugby Union	1886
<b>Ireland</b>	Irish Rugby Football Union	1886
<b>Wales</b>	Welsh Rugby Union	1886
<b>England</b>	Rugby Football Union	1890
<b>Australia</b>	Australian Rugby Union	1949
<b>New Zealand</b>	New Zealand Rugby Union	1949
<b>South Africa</b>	South African Rugby Union	1949
<b>France</b>	Fédération Française de Rugby	1978
<b>Argentina</b>	Union Argentina de Rugby	Mar 1987
<b>Canada</b>	Rugby Canada	Mar 1987
<b>Italy</b>	Federazione Italiana Rugby	Mar 1987
<b>Japan</b>	Japan Rugby Football Union	Mar 1987
<b>United States</b>	USA Rugby Football Union	Mar 1987
<b>Zimbabwe</b>	Zimbabwe Rugby Union	Mar 1987
<b>Fiji</b>	Fiji Rugby Union	Nov 1987
<b>Tonga</b>	Tonga Rugby Football Union	Nov 1987
<b>Romania</b>	Federatia Romana de Rugbi	Nov 1987
<b>Belgium</b>	Fédération Belge de Rugby	Mar 1988
<b>Chinese Taipei</b>	Chinese Taipei Rugby Football Union	Mar 1988
<b>Denmark</b>	Dansk Rugby Union	Mar 1988
<b>Ivory Coast</b>	Fédération Ivoirienne de Rugby	Mar 1988
<b>Malaysia</b>	Malaysian Rugby Union	Mar 1988
<b>Morocco</b>	Fédération Royale Marocaine de Rugby	Mar 1988
<b>Netherlands</b>	Nederlands Rugby Bond	Mar 1988
<b>Poland</b>	Polski Związek Rugby	Mar 1988
<b>Spain</b>	Federación Española de Rugby	Mar 1988
<b>Sweden</b>	Svenska Rugby Forbundet	Mar 1988
<b>Tunisia</b>	Fédération Tunisienne de Rugby	Mar 1988
<b>Samoa</b>	Samoa Rugby Union	Mar 1988
<b>Serbia</b>	Rugby Union of Serbia	Mar 1988
<b>Czech Republic</b>	Ceska Rugbyova Unie	Nov 1988

<i>Country</i>	<i>Union/Federation</i>	<i>Year of Entry</i>
<b>Hong Kong</b>	Hong Kong Rugby Football Union	Nov 1988
<b>Israel</b>	Israel Rugby Union	Nov 1988
<b>Korea</b>	Korea Rugby Union	Nov 1988
<b>Portugal</b>	Federação Portuguesa de Rugby	Nov 1988
<b>Sri Lanka</b>	Sri Lanka Rugby Football Union	Nov 1988
<b>Switzerland</b>	Fédération Suisse de Rugby	Nov 1988
<b>Germany</b>	Deutscher Rugby Verband	Nov 1988
<b>Paraguay</b>	Union de Rugby del Paraguay	Apr 1989
<b>Uruguay</b>	Union de Rugby del Uruguay	Apr 1989
<b>Singapore</b>	Singapore Rugby Union	Nov 1989
<b>Thailand</b>	Thai Rugby Union	Nov 1989
<b>Kenya</b>	Kenya Rugby Football Union	Mar 1990
<b>Namibia</b>	Namibia Rugby Union	Mar 1990
<b>Russia</b>	Rugby Union of Russia	Oct 1990
<b>Andorra</b>	Federació Andorrana de Rugby	Nov 1991
<b>Chile</b>	Federación de Rugby de Chile	Nov 1991
<b>Hungary</b>	Magyar Rögbi Szövetség	Nov 1991
<b>Latvia</b>	Latvia Rugby Federation	Nov 1991
<b>Luxembourg</b>	Fédération Luxembourgeoise de Rugby	Nov 1991
<b>Georgia</b>	Georgian Rugby Union	Feb 1992
<b>Lithuania</b>	Fédération Lithuanienne de Rugby	Apr 1992
<b>Bermuda</b>	Bermuda Rugby Union	Apr 1992
<b>Austria</b>	Osterreichischer Rugby Verband	Nov 1992
<b>Bulgaria</b>	Bulgarian Rugby Federation	Nov 1992
<b>Croatia</b>	Hrvatski Ragbijaški Savez	Nov 1992
<b>Trinidad &amp; Tobago</b>	Trinidad & Tobago Rugby Football Union	Nov 1992
<b>Ukraine</b>	National Rugby Federation of Ukraine	Nov 1992
<b>Norway</b>	Norges Rugby Forbund	Apr 1993
<b>Papua New Guinea</b>	Papua New Guinea Rugby Football Union	Oct 1993
<b>Tahiti</b>	Fédération Tahitienne de Rugby Française de Polynésie	Mar 1994



<i>Country</i>	<i>Union/Federation</i>	<i>Year of Entry</i>
<b>Moldova</b>	Federatia de Rugby din Moldovei	Mar 1994
<b>Bahamas</b>	Bahamas Rugby Football Union	Oct 1994
<b>Botswana</b>	Botswana Rugby Union	Oct 1994
<b>Cook Islands</b>	Cook Islands Rugby Union	Mar 1995
<b>Zambia</b>	Zambia Rugby Football Union	Mar 1995
<b>Guyana</b>	Guyana Rugby Football Union	Oct 1995
<b>Barbados</b>	Barbados Rugby Football Union	Oct 1995
<b>Brazil</b>	Associação Brasileira de Rugby	Oct 1995
<b>Slovenia</b>	Rugby Zveza Slovenie	Oct 1996
<b>Bosnia &amp; Herzegovina</b>	Ragbi Savez Republike Bosne	Oct 1996
<b>Jamaica</b>	Jamaica Rugby Football Union	Oct 1996
<b>China</b>	Chinese Rugby Football Association	Jan 1997
<b>Cayman Islands</b>	Cayman Rugby Union	July 1997
<b>Kazakhstan</b>	Kazakhstan Rugby Federation	July 1997
<b>Uganda</b>	Uganda Rugby Football Union	July 1997
<b>Madagascar</b>	Fédération Malagasy de Rugby	Jan 1998
<b>Monaco</b>	Fédération Monégasque de Rugby	Jan 1998
<b>Swaziland</b>	Swaziland Rugby Union	Jan 1998
<b>Guam</b>	Guam Rugby Football Union	Apr 1998
<b>Venezuela</b>	Federación Venezolana de Rugby Amateur	Oct 1998
<b>Cameroon</b>	Fédération Camerounaise de Rugby	Apr 1999
<b>Colombia</b>	Federación Colombiana de Rugby	Apr 1999
<b>India</b>	Indian Rugby Football Union	Apr 1999
<b>Niue</b>	Niue Rugby Football Union	Apr 1999
<b>Peru</b>	Union Peruana de Rugby	Apr 1999
<b>Senegal</b>	Fédération Sénégalaise de Rugby	Nov 1999
<b>Solomon Islands</b>	Solomon Islands Rugby Union Federation	Nov 1999
<b>Vanuatu</b>	Vanuatu Rugby Football Union	Nov 1999
<b>Malta</b>	Malta Rugby Football Union	Mar 2000
<b>Nigeria</b>	Nigeria Rugby Football Association	Mar 2001
<b>Finland</b>	Suomen Rugbyliitto	May 2001

<i>Country</i>	<i>Union/Federation</i>	<i>Year of Entry</i>
<b>St. Vincent &amp; The Grenadines</b>	St. Vincent & The Grenadines Rugby Union Football Club	Jun 2001
<b>Mexico</b>	Federación Mexicana de Rugby AC	Nov 2006
<b>Pakistan</b>	Pakistan Rugby Union	Nov 2008
<b>Philippines</b>	The Philippines Rugby Football Union	Nov 2008
<b>Mauritius</b>	Rugby Union Mauritius	May 2009
<b>American Samoa</b>	American Samoa Rugby Football Union	May 2012
<b>United Arab Emirates</b>	United Arab Emirates Rugby Federation	Nov 2012
<b>Indonesia</b>	Persatuan Rugby Union Indonesia	Nov 2013
<b>Uzbekistan</b>	Uzbekistan Rugby Union	Nov 2004
<b>Rwanda</b>	Fédération Rwandaise de Rugby	Apr 2004

---

**ASSOCIATE MEMBERS**

<i>Country</i>	<i>Union/Federation</i>	<i>Year of Entry</i>
<b>British Virgin Islands</b>	British Virgin Island Rugby Union	Jun 2001
<b>Tanzania</b>	Tanzania Rugby Union	Apr 2004
<b>Togo</b>	Fédération Togolaise de Rugby	Apr 2004
<b>Ghana</b>	Ghana Rugby Union	Apr 2004
<b>Mali</b>	Fédération Malienne de Rugby	Apr 2004
<b>Burundi</b>	Fédération Burundaise de Rugby	Apr 2004
<b>Azerbaijan</b>	Azerbaijan Rugby Union	Apr 2004
<b>Kyrgystan</b>	Kyrgystan Rugby Union	Nov 2004
<b>Mongolia</b>	The Mongolian Rugby Union	Nov 2004
<b>Lao</b>	Lao Rugby Federation	Nov 2004
<b>St. Lucia</b>	St. Lucia Rugby Football Union	Oct 1996
<b>Iran</b>	Iran Rugby Federation	Nov 2010
<b>Brunei</b>	Brunei Rugby Football Union	Nov 2013
<b>Costa Rica</b>	Federación de Rugby de Costa Rica	May 2014
<b>Cyprus</b>	Cyprus Rugby Federation	Nov 2014
<b>Guatemala</b>	Asociación Deportiva Nacional de Rugby	May 2016
<b>Slovenia</b>	Slovenská Rugbyová Únia	May 2016

## REGIONAL ASSOCIATIONS

Asia Rugby

Oceania Rugby

Rugby Africa

Rugby Americas North

Rugby Europe

Sudamérica Rugby



### **WORLD RUGBY**

World Rugby House  
8-10 Pembroke Street Lower  
Dublin 2  
Ireland

**t:** +353-1-240-9200  
**e:** [info@worldrugby.org](mailto:info@worldrugby.org)

#### **Chairman**

Bill Beaumont

**t:** +353-1-240-9270  
**e:** [myra.mcglynn@worldrugby.org](mailto:myra.mcglynn@worldrugby.org)

#### **CEO/Secretary General**

Brett Gosper

**t:** +353-1-240-9270  
**e:** [brett.gosper@worldrugby.org](mailto:brett.gosper@worldrugby.org)

#### **Head of Commercial, Broadcast and Marketing**

Murray Barnett

**t:** +353-1-240-9200  
**e:** [murray.barnett@worldrugby.org](mailto:murray.barnett@worldrugby.org)

#### **Head of Communications**

Dominic Rumbles

**t:** +353-1-240-9206  
**e:** [dominic.rumbles@worldrugby.org](mailto:dominic.rumbles@worldrugby.org)

#### **Head of Competitions and Performance**

Mark Egan

**t:** +353-1-240-9225  
**e:** [mark.egan@worldrugby.org](mailto:mark.egan@worldrugby.org)

**Head of Development and International Relations**

David Carrigy

t: +353-1-240-9280

e: david.carrigy@worldrugby.org

**Head of Finance**

Robert Brophy

t: +353-1-240-9211

e: robert.brophy@worldrugby.org

**Head of Human Resources**

Lisa Lowry

t: +353-1-240-9261

e: lisa.lowry@worldrugby.org

**Head of Legal and Legislative Affairs**

Alistair Maclean

t: +353-1-240-9256

e: alistair.maclean@worldrugby.org

**Head of Rugby World Cup**

Alan Gilpin

t: +353-1-240-9224

e: alan.gilpin@worldrugby.org

**Head of Technical Services**

Mark Harrington

t: +353-1-240-9294

e: mark.harrington@worldrugby.org



**WORLD  
RUGBY™**

# SECTION 2

## BYE-LAWS





---

<b>SECTION 2</b>	<b>Bye-Laws</b>	<b>23</b>
	1. Definitions	27
	2. Management and Control	31
	3. Objectives and Functions of World Rugby	33
	4. Participation in the Game	35
	5. Laws of the Game	37
	6. World Rugby	39
	7. Binding Agreement	41
	8. General Assembly	43
	9. The Council	45
	10. The Executive Committee	55
	11. Standing Committees	61
	12. Emergency Decisions	65
	13. Other Committees	67
	14. Membership	69
	15. Interpretation	71



## BYE-LAW 1. DEFINITIONS

1.1 For the purposes of these Bye-Laws the following terms have the meanings below assigned to them:

**Association** means an Association of national Rugby Unions recognised by the Council and elected to be a member of World Rugby by a majority of at least three quarters of the Council.

**Audit and Risk Committee** means the committee set out in Bye-Law 11.4

**Bye-Laws** means the Bye-Laws for the time being adopted by World Rugby and in force.

**Chairman** means the chairman of Council from time to time, who shall be a member of Council at the time of his election as Chairman.

**Chief Executive Officer/CEO** means the chief executive officer or secretary general of World Rugby and the Company from time to time.

**Chief Medical Officer** means the chief medical officer of World Rugby appointed by the Chief Executive Officer from time to time.

**Council** means World Rugby's Council which comprises representatives of Unions and Associations appointed as provided in the Bye-Laws and who comprise the committee that has the ultimate and supreme legislative authority in respect of the affairs of World Rugby. The powers of the Council are set out in Bye-Law 9.4.

**Common Association Constitution** means the Constitution approved by Council pursuant to which Associations are required to administer and govern their affairs, management and governance.

**Company** means World Rugby Limited, a private company limited by shares incorporated in Ireland through which the Executive Committee shall carry out its functions.

**Effective Date** means the effective date of commencement of these Bye-Laws being October 27, 2015 (without prejudice to the retrospective effect of Bye-Laws 16.1 and 16.2). Prior to such date the pre-existing Bye-Laws of World Rugby shall remain fully in force and effect.

**Executive Committee** means the committee set out in Bye-Law 10. The Executive Committee shall carry out its role and functions through the Company of which the members of the Executive Committee shall be directors.

**Foundation Union** means the Rugby Football Union, the Scottish Rugby Union, the Irish Rugby Football Union, the Welsh Rugby Union, the Australian Rugby Football Union, the New Zealand Rugby Football Union, the South African Rugby Football Union and the Fédération Française de Rugby.

**Game** means rugby football played in accordance with the Laws of the Game.

**Independent Vote Chair** means the independent chair of the voting process pursuant to Bye-Law 9.6.2(b).

**Initial Independent Delegates** means the persons appointed to fulfil the roles of the independent Chairman and Independent Member on the initial Nominations Committee by the Executive Committee pursuant to the transitional provisions set out in Bye-Law 11.6.5.

**International Match** means a Match played between National Representative Teams selected by Unions.

**Independence Criteria** means that the person has not held any position or been employed in any Union, Club and/or Rugby Body for at least three years prior to the time of appointment and desists from any such involvement throughout the duration of his tenure on the Executive Committee and/or Standing Committee.

**Independent Member** means a member of the Executive Committee and/or a Standing Committee who meets the Independence Criteria.

**Match** means a contest in which two teams compete against the other in playing the Game.

**Material Benefit** means money, consideration, gifts or other benefits whatsoever promised or given to a Person or at his direction, but does not include reimbursement of expenses incurred for reasonable travel, accommodation, subsistence or other expenses incurred in relation to the Game.

**National Representative Team** means a team selected by a Union to represent that Union.

**National Squad** means the group of players (of any number) selected by a Union from time to time from which players may be nominated to represent that Union's two Senior National Representative Teams.

**Nominations Committee** means the committee set out in Bye-Law 11.6.

**Officer** means any of the Chairman of Council, the Vice-Chairman of Council and the Chief Executive Officer from time to time and Officers shall mean such persons collectively.

**Other Committee** means a committee set out in or established under Bye-Law 13.

**Person** means a player, trainer, referee, touch judge, coach, selector, medical officer, physiotherapist or any other individual who is or has been at any time involved in the Game, or in the organisation, administration or promotion of the Game.

**Previous Bye-Laws** means the Bye-Laws of World Rugby in existence immediately prior to the Effective Date.

**Regional Committee** means the committee set out in Bye-Law 11.5.

**Regulations** means Regulations Relating to the Game and General Regulations binding on all Unions and Associations and which have already been passed by the Council or which may hereafter be passed by the Council under the powers herein contained.

**Regulations Committee** means the committee set out in Bye-Law 11.3.

**Representative** means a member of the Council.

**Rugby Committee** means the committee set out in Bye-Law 11.2.

**Standing Committee** means a committee set out in Bye-Law 11.

**Tours Agreement** means the agreement approved by the Council which provides for the terms under which a Union visits another Union or Unions.

**Union** means every national Rugby Union for the time being in membership of World Rugby.

**Vice-Chairman** means the vice-chairman of Council from time to time, who will be a Representative of either a Union or Association on Council.

**World Rugby** means the association of Unions and/or Associations, in membership of World Rugby in accordance with the Bye-Laws, formerly known as International Rugby Board.



---

**BYE-LAW 2. MANAGEMENT AND CONTROL**

- (a) The Council has the ultimate and supreme legislative authority in respect of the affairs of World Rugby which it shall exercise in accordance with these Bye-Laws. The Executive Committee is responsible for formulating and overseeing implementation of World Rugby's strategic plan and application of policy decisions in accordance with the provisions of these Bye-Laws.
- (b) Funds, securities and other property belonging to or at the disposal of World Rugby may be invested in any property or class of security or securities without any restriction whatsoever and shall be made in the names of nominees or the name of a nominee company as may from time to time be decided by the Council or the Executive Committee (as the case may be). The nominees or nominee company (as the case may be) shall have the custody of all securities and documents of title relating to the investments but such investments nevertheless remain at the disposal of World Rugby acting by the Council or the Executive Committee (as the case may be).
- (c) Without limiting the generality of the foregoing World Rugby acting by the Council (or the Executive Committee to the extent permitted by the memorandum and articles of association of the Company) shall have power to hold purchase or take on lease or licence any real or personal property and shall have power to authorise the sale, exchange, lease, mortgage, charge or other disposition of or dealing with any such property.
- (d) The Council or the Executive Committee (to the extent permitted by the memorandum and articles of association of the Company) shall have power on behalf of World Rugby to raise or borrow any sum or sums of money with or without security for any purpose which it considers necessary to further the objects of World Rugby and to secure the repayment of the same by mortgaging or charging any of World Rugby's property.
- (e) The Council may appoint one or more of its members or any nominee company (which may be the Company) to act in legal proceedings in the name of and on behalf of World Rugby on such terms (whether as to costs or otherwise) as the Council may determine.





---

**BYE-LAW 3. OBJECTIVES AND FUNCTIONS OF WORLD RUGBY**

- (a) Promoting, fostering, developing, extending and governing the Game.
- (b) Framing and interpreting the Bye-Laws, the Regulations and the Laws of the Game.
- (c) Deciding and/or settling all matters or disputes relating to or arising out of the playing of or the proposed playing of the Game or a Match or any dispute between two or more Unions relating to the application of the Regulations.
- (d) To regulate and co-ordinate arrangements to ensure that there is a fair and equitable programme of matches, tours and tournaments for Senior National Representative Teams of all Council Member Unions.
- (e) Controlling all other matters of an international character affecting the Game.
- (f) To prevent discrimination of any kind against a country, private person or groups of people on account of ethnic origin, gender, language, religion, politics or any other reason.



---

**BYE-LAW 4. PARTICIPATION IN THE GAME**

- (a) The Game is an open game where Persons may receive Material Benefit notwithstanding that for the majority of Persons the Game will remain a non-vocational leisure activity.
- (b) Pursuant to Bye-Law 3(b) the Council shall as and when it deems necessary frame and adopt Regulations which shall be binding on all Unions and their constituent bodies.
- (c) Subject to any legal requirements in the country of its jurisdiction a Union may pass additional more restrictive regulations provided that they are not in conflict with the Regulations. Such regulations shall have effect only within the jurisdiction of that Union.
- (d) Associations must comply fully with the Common Association Constitution as approved by the Council.



---

**BYE-LAW 5. LAWS OF THE GAME**

- (a) The Laws of the Game, or any alterations thereto or interpretations thereof, shall be promulgated by World Rugby in the English language and shall be binding and uniformly observed in all matches except that it shall be lawful for the Council to direct or authorise any Union to practise for experimental purposes only a specific variation from the Laws of the Game. Any such Union shall implement such direction or exercise such authority in accordance with any conditions that may be laid down by the Council and shall furnish to the Council such information as it may require regarding the results ascertained from the experiment.
- (b) The Council shall also be entitled as it deems fit to direct or authorise all Unions to practice for experimental purposes only a specific variation or series of variations from the Laws of the Game. All Unions shall implement such direction or exercise such authority in accordance with any conditions that may be laid down by the Council and shall furnish to the Council such information as it may require regarding the results ascertained from the experiment.
- (c) Alterations to the Laws of the Game, save for with respect to the Seven-a-Side Variations, and consideration of proposals in respect thereof shall, save where such change and/or proposal is based upon safety considerations and/or other unforeseeable and/or emergency circumstances, only be made on one occasion during the four-year period between each Rugby World Cup Finals with there being at least one year between the commencement of the Law amendments and the scheduled start of the Rugby World Cup Finals.
- (d) Alterations to the Laws of the Game – Sevens-a-Side Variations and consideration of proposals in respect thereof shall, save where such change and/or proposal is based upon safety considerations and/or other unforeseeable and/or emergency circumstances, only be made on one occasion during the four year period between each Summer Olympic Games with there being at least one year between the commencement of the Law amendments and the scheduled start of the Summer Olympic Games.



---

**BYE-LAW 6. WORLD RUGBY**

- (a) World Rugby shall consist of those Unions and Associations who are members of World Rugby pursuant to these Bye-Laws.
- (b) The Executive Committee shall initially consider applications for membership of World Rugby made by Unions and Associations. The Executive Committee is entitled to make recommendations to the Council as to whether the Union or Association should be admitted as a member and if so whether on the basis of full or associate membership. For the avoidance of doubt and notwithstanding any recommendation of the Executive Committee, Council has the ultimate authority to admit a Union and/or Association to membership of World Rugby and to determine whether such Union and/or Association shall be a full or associate member. It shall be a condition of obtaining membership of World Rugby that Unions or Associations meet the applicable membership criteria approved by Council from time to time.
- (c) Unions or Associations who wish to be considered for membership of World Rugby must demonstrate compliance with the World Rugby Membership Pathway and Membership Criteria established by Council from time to time and set out in detail at [www.worldrugby.org](http://www.worldrugby.org). Such criteria may change from time to time as determined by Council and without notice to non-members.
- (d) Without limiting the effect of Regulation 18.6.1(d) in relation to the full suspension and/or expulsion of a Union or Association in the event of a breach of the Bye-Laws and/or Regulations, Unions or Associations that do not meet membership criteria and/or other conditions governing their membership of World Rugby may have their membership provisionally suspended by the Executive Committee pending a meeting of the Council. Only the Council shall be entitled to fully suspend and/or expel a Union or Association from membership of World Rugby.





---

**BYE-LAW 7. BINDING AGREEMENT**

Membership of World Rugby by a Union or Association shall be effective as an agreement binding such Union or Association (which agreement requires such Union or Association to similarly by agreement bind its affiliated membership which such Union or Association undertakes to do) to abide by the Bye-Laws, Regulations and Laws of the Game and to accept and enforce all the decisions of World Rugby, Council and the Executive Committee (as the case may be) in respect of the playing and/or administration of the Game throughout the country or countries within the jurisdiction of such Union or Association. Any breach of this agreement or any conduct which may be prejudicial to the interests of World Rugby or of the Game shall render such Union or Association liable to disciplinary action in accordance with Regulation 18 of the Regulations Relating to the Game.



---

**BYE-LAW 8. GENERAL ASSEMBLY**

A General Assembly of World Rugby shall be held biennially at a venue and on a date determined by the Council for the transaction of the following business:

- (a) to consider and approve the minutes of the previous General Assembly;
- (b) to receive and consider a report from the Council;
- (c) to note the composition of committees of the Council;
- (d) to consider any other business referred to the General Assembly by the Council; and
- (e) to make recommendations to the Council as appropriate regarding the foregoing.

**8.1 Notice of General Assembly**

At least ten weeks' notice of the date of the General Assembly shall be given to Unions and Associations and a copy of the agenda and supporting papers shall accompany the notice of the General Assembly.

**8.2 Chairman**

The Chairman of the Council, or in his absence the Vice-Chairman of the Council, shall act as Chairman of any General Assembly.

**8.3 Permitted Attendees**

- (a) Attendees of the General Assembly shall be those delegates who are:
  - (i) in the case of each of the Unions or Associations represented on the Council, its representative or representatives of the Council;
  - (ii) in the case of each of the Unions or Associations not represented on the Council one delegate who must be or have been a member of the governing body of that Union or Association.
- (b) Notice of the names and addresses of delegates, signed by the Secretary of the Union or Association concerned, must be received by the Chief Executive Officer of World Rugby at least three weeks before the date of the General Assembly at which the delegate is to act.
- (c) No delegate shall represent more than one Union or Association.
- (d) No Union or Association shall be entitled to send a delegate to a General Assembly unless such a Union or Association shall have made to World Rugby all payments due under Bye-Law 9.12(a).

- (e) No Union or Association shall be entitled to send a delegate to a General Assembly if such a Union or Association is in breach (or alleged to be in breach) of Bye-Law 7 or is subject to sanction under Bye-Law 9.4(r).

#### **8.4 Proxies**

A Union or Association may appoint a proxy to attend the General Assembly in place of a duly appointed delegate who is unable to attend providing such proxy is:

- (a) a member of the Union or Association duly appointed as proxy by that Union or Association to attend the meeting; and
- (b) supplied with a nomination paper signed by the Secretary of the Union or Association concerned, authorising him to attend the General Assembly on the Union's or Association's behalf, and to record its vote on specified agenda items or on topics requiring a vote.

#### **8.5 Quorum**

The quorum of a General Assembly shall be such number of delegates who represent more than fifty per cent of the Unions and Associations.

#### **8.6 Voting**

- (a) Each Union or Association is entitled to one vote.
- (b) Decisions and recommendations shall be decided by a simple majority.
- (c) Voting shall be by ballot unless decided otherwise by a majority of the delegates present.

---

**BYE-LAW 9. THE COUNCIL****9.1 Representatives on Council**

The Council shall consist of:

- (a) Two Representatives from each of the Foundation Unions, each of which Representatives shall have one vote;
- (b) One Representative from each of the Unión Argentina de Rugby, the Canadian Rugby Union, the Federazione Italiana Rugby, the Japan Rugby Football Union, each of which Representatives shall have one vote; and
- (c) One Representative from each of the following Associations: Asia Rugby, Rugby Africa, Rugby Europe, Oceania Rugby, Sudamericana Rugby (Rugby Americas South) and Rugby Americas North, each of which Representatives shall have one vote; and
- (d) The Officers referred to in Bye-Law 9.7.
- (e) From immediately after the Annual Meeting of Council in May 2016 the following changes shall be made to the voting and membership structure:
  - (i) The Association Representatives shall have two votes;
  - (ii) Unions which have qualified for the Rugby World Cup Finals Tournament on two consecutive occasions in the assessment period (8 years) shall have one Representative who shall have one vote;
  - (iii) Unions which have qualified for the Rugby World Cup Finals Tournament on two consecutive occasions in the assessment period (8 years) and who play in a major Championship (being for this purpose the Six Nations or SANZAR Rugby Championships) shall have one Representative who shall have one vote;
  - (iv) Unions which have qualified for RWC on two consecutive occasions in assessment period (8 years) and satisfy the criteria below shall have one additional vote but no additional Representative:
    - a) contribute to the Game by having a Union audited average annual turnover greater than £20million<sup>1</sup> over the previous four year period (to reflect its investment in the Game); and

---

<sup>1</sup> The Nominations Committee shall have discretion in examining the accounts of an applicant Union to recommend to Council a suitable comparative currency index when determining compliance with this criteria;

- b) bid to host (as voted at Council) or hosts a major event in the assessment period (8 years) or is scheduled to do so in the succeeding 4 year period (major events being: a Rugby World Cup Finals Tournament, Rugby World Cup Sevens, Women's Rugby World Cup, U20/Junior World Championship, U20/Junior World Trophy and/or Sevens World Series); and
  - c) have in place a sustainable Women's fifteens programme with national team participation in the Women's Rugby World Cup or Rugby World Cup qualifiers in the assessment period (8 years); and
  - d) have in place a sustainable Men's sevens programme, Women's sevens programme, reflected by (at a minimum) participation in Association competitions and/or the Sevens World Series (male and female).
- (f) All new Unions wishing to join Council will also be subject to review and recommendation by the Nominations Committee and must comply with the criteria required for Eligibility for Consideration of Membership to Council (the "Criteria"). The Criteria may be reviewed from time to time but include the requirement to demonstrate compliance with the provisions below:
- (i) Fully comply with World Rugby Membership Criteria
  - (ii) Be in good standing with World Rugby (and in particular that it has filed and continues to file all appropriate paperwork / reports required by World Rugby and has paid all fees which are due for its membership or the renewal thereof)
  - (iii) Be a member of its Association recognised by Council
  - (iv) Be in good standing with its National Olympic Committee (NOC) and/or National Sports Ministry
  - (v) Be able to demonstrate that Good Governance practice is in operation including but not limited to in the following areas:
    - Constitution, Bye-Laws & Regulations Relating to the Game are fully applied;
    - Five years of unqualified audited accounts;
    - Five years of AGM Minutes provided;
    - Transparent links with membership evident;
    - That Unions have jurisdiction and control over players & the professional game in their Union territory; and
    - Comply with any National or regional legislation, in the area of good governance for sporting bodies.

The Representatives set out in (a) to (c) and (e) above shall be elected by their Unions or Associations (as the case may be).

The Officers shall be elected in accordance with the provisions of Bye-Law 9.7.

## **9.2 Composition**

- (a) Each Foundation Union shall be entitled to send two Representatives, who must be or have been a member of the governing body of that Union, to all meetings of the Council.
- (b) Unions and Associations, other than Foundation Unions, represented on the Council shall be entitled to send one Representative, who must be or have been a member of the governing body of that Union or Association, to all meetings of the Council.
- (c) The Officers shall be entitled to attend and speak at all meetings of the Council.
- (d) From immediately after the Annual Meeting of Council in May 2016 the following changes shall be made to the composition structure:
  - (i) Each Association Representative shall have two votes;
  - (ii) Unions, other than Foundation Unions, represented on Council shall be entitled to send the number of Representatives to which they are eligible and entitled in accordance with Bye-Law 9.1(e).

## **9.3 Quorum**

The quorum for any meeting of the Council shall be 50% of the Representatives (excluding the Chairman).

## **9.4 Powers of the Council**

As the ultimate and supreme legislative authority of World Rugby, Council has the power to make decisions on the following:

- (a) The ratification of the mission, strategy, goals and plan of World Rugby and the oversight of the implementation thereof by the Executive Committee;
- (b) The consideration and approval of the minutes of previous Council Meetings;
- (c) To elect the Chairman and Vice-Chairman in accordance with Bye-Law 9.6.2;
- (d) To elect seven Representatives to the Executive Committee and to approve two Independent Members of the Executive Committee proposed by the Nominations Committee in accordance with Bye-Law 10.2;

- (e) To receive a report from the Executive Committee and to give consideration to the actions taken by the Executive Committee since the last Council Meeting;
- (f) To ratify, or otherwise, as it considers appropriate, the emergency decisions taken by the Executive Committee under Bye-Law 12;
- (g) To receive and approve the audited group financial statements of World Rugby for the preceding financial year;
- (h) As and when appropriate at the Annual and Interim Meetings, to elect the Officers and seven members of the Executive Committee, to approve the nominations of the two Independent Members of the Executive Committee proposed by the Nominations Committee, and, in appropriate circumstances, to remove members of the Executive Committee;
- (i) To consider and approve, as appropriate, any amendment or alteration to:
  - (i) the Bye-Laws;
  - (ii) the Regulations;
  - (iii) the Laws of the Game which have been duly proposed and of which due notice shall have been given as provided in Bye-Laws 5, 9.7 and 9.8;
- (j) To receive reports from the Executive Committee on the work of the Standing Committees since the last Council Meeting;
- (k) To consider any proposals or business of which due notice shall have been given as provided for in Bye-Law 9.12;
- (l) To determine the date, venue and agenda for the General Assembly;
- (m) To determine the Host Union(s) for all Rugby World Cup Tournaments (Men's, Women's and Sevens);
- (n) To take such other decisions and/or steps necessary and/or incidental to the exercise of the above powers;
- (o) To appoint judicial and appeal personnel in accordance with Regulation 18;
- (p) At any meeting of the Council it shall have power, following a recommendation of the Executive Committee, to elect to membership of World Rugby any national Rugby Football Union. Such Union shall be proposed and seconded by and its election must be supported by a majority of at least three-quarters of the Representatives present;
- (q) Without prejudice to the generality of these Bye-Laws, the Council may expel or suspend from membership of World Rugby or impose



such other punishment or penalty, including a fine, as it considers fit on a Union or Association for any infringement of the Bye-Laws or the Regulations or for any conduct which in the opinion of the Council is prejudicial to the interests of World Rugby or of the Game or which may bring World Rugby or the Game or any Persons, Administrators or Officials into disrepute.

## **9.5 Constitutional Process**

### **9.5.1 Annual and Interim Meetings**

The Council shall meet biannually (“Annual Meeting” and “Interim Meeting”) normally in Dublin in March/April/May and October/November respectively to be determined by the Council. Provided, however, that they may be held at such other occasions, time or times and place or places as a majority of the Council may agree, or failing agreement, in Dublin on a date to be fixed by the Officers as defined in Bye-Law 9.6. The Annual and Interim Meetings shall have the same powers. The Annual and Interim Meetings shall be held for the transaction as appropriate of the business required in accordance with the Powers of Council set out in Bye-Law 9.4.

### **9.5.2 Special Meetings**

If so directed by the Council (or if so requested by no fewer than eight (8) Unions or Associations represented on the Council), the Chief Executive Officer shall convene a special meeting of the Council (“Special Meeting”) for any purpose. Additionally, the Chief Executive Officer shall convene a Special Meeting if so directed by the Executive Committee for the purpose of considering proposed alterations to the Bye-Laws, Regulations Relating to the Game, General Regulations or the Laws of the Game subject to Bye-Law 9.8(g) below. The purpose for which the Special Meeting is being convened shall be notified by the Chief Executive Officer to every Union and Association at least six (6) weeks prior to the date fixed for the Special Meeting unless the Council, in case of extreme urgency, agree by a three-quarter majority that a shorter period of notice may be given.

## **9.6 Officers**

### **9.6.1 Status of Chairman and Vice-Chairman**

- (a) Following election, the Chairman must relinquish any office or paid position within his Union and may not be the President, Vice-President, Chairman, Vice-Chairman, Treasurer or a Representative of his Union or Association or hold any comparable position.
- (b) The Chairman shall be afforded a period of six (6) months to relinquish any such office within his Union or Association, which Union or Association shall in turn be entitled to elect a replacement Representative to the Council.

- (c) The Officers shall be members of all Committees, sub-committees and advisory committees (including any associated working parties/sub-groups) of World Rugby, save for the Nominations Committee where appointments are specified and detailed in Bye-Law 11.6.
- (d) The Chairman shall only have a casting vote at any Council Meeting and Executive Committee meeting.
- (e) The Vice-Chairman role is not independent so the elected Vice-Chairman shall be one of the Representatives of his Union or Association and will not be in addition to that Union or Association's Council member(s).
- (f) If the Chairman shall cease in office then the Vice-Chairman elected pursuant to Bye-Law 9.6.2, shall assume the position of Chairman pro-tem and the Council shall elect a new Chairman and Vice-Chairman at its next meeting.
- (g) If the elected Vice-Chairman shall cease in office then the Chairman shall appoint another member of the Executive Committee to become Vice-Chairman until the next Council meeting.

#### **9.6.2 Election of Chairman and Vice-Chairman**

The Chairman and Vice-Chairman shall be elected initially from the Representatives usually but not necessarily at the Annual Meeting immediately following the quadrennial men's Rugby World Cup Tournament and for a period of four (4) years commencing on 1st July of the same calendar year as approved by the Executive Committee. They shall thereafter be eligible for re-election at the end of their term of office.

- (a) The voting procedure for the Officers shall be as follows:
  - (i) All candidates for Officer positions shall be proposed and seconded by members of Council.
  - (ii) In the event that more than one Candidate is proposed for an available position, the Council shall vote by secret ballot.
  - (iii) To be elected a candidate must achieve a simple majority of the votes held by the Representatives present and entitled to vote pursuant to Bye-Law 9.1 above.
  - (iv) If following a secret ballot none of the candidates have achieved a simple majority the candidate with the lowest number of votes will be eliminated and a new ballot will be taken. If two candidates with the lowest number of votes have an equal number of votes Council will hold a secret ballot to determine which candidate will proceed to the next round of voting. The voting shall continue until a candidate reaches a

simple majority or in the event of a tie the Chairman is called to use his casting vote.

- (v) In the event of a repeated tied vote, the Chairman shall have the casting vote providing he is not a candidate for the position in question.
  - (vi) If the Chairman is a candidate and unable to use the casting vote in the event of a tied vote Council must continue voting until a new Chairman is elected.
- (b) Where the incumbent Chairman and Vice-Chairman are both standing for re-election an Independent Vote Chair shall be appointed by the Executive Committee to manage this voting process.
- (c) To be admissible, all candidatures for the role(s) of Chairman and/or Vice-Chairman must be submitted to the Chief Executive Officer and fulfil the following conditions:
- (i) Be sent in writing duly signed by the candidate and his nominating Union no later than 60 days prior to the Annual Meeting referenced in 9.5.1 above;
  - (ii) Be accompanied by the names of the Representatives who are proposing and seconding the candidate.
- (d) World Rugby shall (i) call for nominations for Chairman and Vice-Chairman no later than 90 days prior to the Annual Meeting and (ii) circulate all Nominations received in compliance with Bye-Law 9.6.2(c) above to all Unions, Associations and Council no less than 45 days prior to the Annual Meeting.
- (e) For transitional purposes:
- (i) At the Annual Meeting of Council 2016 only, any candidate for the positions of Chairman or Vice-Chairman who has at that date service the maximum permitted term (under Bye-Law 10.3.1) on the Executive Committee shall, upon election by Council as Chairman or Vice-Chairman be permitted to serve a maximum of two terms, subject to re-election in accordance with these Bye-Laws).

### 9.6.3 **Chief Executive Officer**

The Chief Executive Officer shall be appointed by the Executive Committee on such terms and conditions as the Executive Committee shall from time to time determine.

## 9.7 Alterations to Bye-Laws, Regulations Relating to the Game, General Regulations and Laws of the Game

- (a) Subject to Bye-Law 12 until the time of the next Council meeting, no alterations to the Bye-laws, Regulations Relating to the Game or the Laws of the Game shall be made unless agreed by a three quarter majority of the votes of the Representatives present and entitled to vote pursuant to Bye-Law 9.1 at the Annual or Interim Meetings or at a Special Meeting;
- (b) Subject to Bye-Law 12 until the time of the next Council meeting, no alterations to the General Regulations shall be made unless agreed by a simple majority of the votes of the Representatives present and entitled to vote pursuant to Bye-Law 9.1 at the Annual or Interim Meetings or at a Special Meeting.
- (c) For the purposes of Bye-Law 9.7(a), the three quarter majority shall equate to 75% of the total votes cast inclusive of any abstentions. If a Representative fails to cast a vote(s) this will be considered as an abstention.
- (d) Voting in relation to individual changes to proposed alterations to the Bye-Laws, Regulations Relating to the Game, General Regulations and/or Laws of the Game shall be as follows:
  - (i) a simple majority of the votes of the Representatives present and entitled to vote pursuant to Bye-Law 9.1 shall be required for individual alterations to be made to the proposed alterations;
  - (ii) a final vote on the proposed alteration to the Bye-laws, Regulations Relating to the Game and/or Laws of the Game (following consideration of any individual alterations) shall require a three quarter majority of the votes of the Representatives present and entitled to vote pursuant to Bye-Law 9.1;
  - (iii) a final vote on the proposed alteration to a General Regulation (following consideration of any individual alteration) shall require a simple majority of the votes of the Representatives present and entitled to vote pursuant to Bye-Law 9.1.

## 9.8 Proposed Alterations to Bye-Laws, Regulations Relating to the Game, General Regulations and Laws of the Game

### (a) Annual Meeting

Subject to Bye-Law 5, proposed alterations to the Bye-Laws, Regulations Relating to the Game, General Regulations or Laws of the Game, to be considered at the Annual Meeting shall be sent by the Union, Association, Chairman of the Council, and the Executive Committee, Chairman of any Committee of the Council proposing such alteration or the Chief Executive Officer to the Chief Executive

Officer not later than 15th January in any year and shall be forwarded by the Chief Executive Officer to each Union and Association within 14 days thereafter.

(b) **Interim Meeting**

Subject to Bye-Law 5, proposed alterations to the Bye-Laws, Regulations Relating to the Game, General Regulations or Laws of the Game, to be considered at the Interim Meeting shall be sent by the Union, Association, Chairman of the Council, Chairman of any Committee of the Council and the Executive Committee proposing such alteration or the Chief Executive Officer to the Chief Executive Officer not later than 1st July in that year and shall be forwarded by the Chief Executive Officer to each Union and Association within 14 days thereafter.

(c) Generally any alterations proposed in accordance with (a) and (b) above shall state in respect of each separate proposal:

- (i) the precise wording of the proposed alteration,
- (ii) the reasons for the proposed alteration, and
- (iii) any consequential amendments.

(d) Subject to Bye-Law 5, any proposed amendments to such proposals must reach the Chief Executive Officer no later than 25th February in respect of the Annual Meeting and 31st August in respect of the Interim Meeting, in the relevant year and these will then be forwarded by him to each Union and Association by 15th March and 14th September respectively in the relevant year.

(e) Subject to Bye-Law 5, where any proposals for alterations are to be dealt with at a Special Meeting the latest dates for receiving proposals and proposed amendments to them shall be determined by the Council and notified by the Chief Executive Officer to every Union and Association.

(f) Subject to Bye-Law 12 until the time of the next Council meeting, no alterations to the Bye-Laws, Regulations Relating to the Game, General Regulations or Laws of the Game shall be made without due notice as provided for in the Bye-Laws, unless it is an alteration consequential on or arising from some other proposed alteration of which due notice has been given, and unless three-quarters of the Representatives present consent to the matter being considered without due notice.

(g) The Council, in considering any duly submitted proposal to alter the Bye-Laws, Regulations Relating to the Game, General Regulations or Laws of the Game and proposed amendments thereto may modify, alter and amend such proposals provided there is a three quarters majority of the votes of the Representatives present and entitled to vote pursuant to Bye-Law 9.1 at the Annual or Interim

Meetings or at a Special Meeting has been obtained, and such modified, altered or amended proposals shall thereafter be incorporated as part of the Bye-Laws, Regulations Relating to the Game, General Regulations or Laws of the Game.

### **9.9 Notice of Other Business**

Notice of any other business which falls within the purview of Council to be dealt with at the Annual or Interim Meetings (save for proposals pursuant to Bye-Law 9.7), shall be sent to the Chief Executive Officer not later than 31st January in respect of the Annual Meeting and 31st August in respect of the Interim Meeting in the relevant year and the Chief Executive Officer shall forward such notice to every Union and Association by 14th February and 14th September respectively in the relevant year.

### **9.10 Finance**

- (a) The Council and the Executive Committee (as the case may be) shall have control of the funds and property of World Rugby, and in addition to the powers contained in Bye-Law 2 and without limiting the generality of the foregoing the Council shall have the power to fix from time to time the amount of the subscription to be paid to World Rugby by a Union and Association;
- (b) Audited accounts of World Rugby and of its associated entities where required shall be made up to the 31st December in each year and shall be signed by the Chairman and the CEO;
- (c) All expenses incurred in connection with attendance at meetings of the General Assembly, Council, Executive Committee or any Standing Committee, Advisory Committee of the Council, including working parties or sub-groups or advisory groups, shall be defrayed in such manner as the Council shall from time to time determine;
- (d) World Rugby's income shall accrue from the subscriptions paid by Unions and Associations pursuant to Bye-Law 9.12(a), from World Rugby's investments and securities, and from any other income source.

---

**BYE-LAW 10. THE EXECUTIVE COMMITTEE****10.1 Composition of Executive Committee**

- 10.1.1 Subject to the transitional provisions set out in Bye-Law 16 as approved by the Executive Committee, the Executive Committee shall comprise of the Officers, seven other members elected by the Council from the Representatives and two Independent Members proposed by the Nominations Committee and approved by the Council. No Union or Association (excluding, for the avoidance of doubt, the Union of the Chairman) shall have more than one representative on the Executive Committee. The Executive Committee shall be chaired by the Chairman. No employee or contractor of a Union can be elected to the Executive Committee.
- 10.1.2 The Executive Committee will carry out its functions as an incorporated entity through the Company. The members of the Executive Committee from time to time shall be directors of the Company and World Rugby Development Limited and may also be directors of other companies in the World Rugby group of companies. All members of the Executive Committee shall act in accordance with their fiduciary duties and in accordance with applicable laws and shall, for the avoidance of doubt, recuse themselves from any decision in which they have a conflict of interest.
- 10.1.3 The Executive Committee may, from time to time, establish Other Committees, working parties, sub-groups and advisory groups as it considers necessary.

**10.2 Appointment of the Executive Committee**

- 10.2.1 The Chairman and Vice-Chairman shall be elected in accordance with Bye-Law 9.6.2.
- 10.2.2 The Chief Executive Officer shall be appointed in accordance with Bye-Law 9.6.3.
- 10.2.3 Seven other Members of the Executive Committee shall be elected by the Council from the Representatives in accordance with the procedure set out in Bye-Law 10.2.4 below.
- 10.2.4 The voting procedure for the seven Members of the Executive Committee elected from the Representatives shall be as follows: Representatives will be proposed and seconded by another Representative. In the event that more than one Representative is proposed for an available position on the Executive Committee, the Council shall vote by secret ballot in accordance with the votes of the Representatives present and entitled to vote pursuant to Bye-Law 9.1. The Representative(s) with the lowest number of votes shall drop out. The Representative(s) with the highest number of votes shall be appointed. In the event of the Representatives with the lowest number of votes being tied, this procedure will be repeated by the Council, again voting by secret ballot until all positions on the

Executive Committee have been filled. In the event of a repeated tied vote, the Chairman shall have the casting vote.

- 10.2.5 The two Independent Members of the Executive Committee shall be proposed by the Nominations Committee and, subject to the approval of Council, appointed to the Executive Committee. In the event that Council does not approve the proposal(s) of the Nominations Committee, the Nominations Committee shall make further proposal(s) until such time as the Council approves two Independent Members of the Executive Committee. A person appointed as an Independent Member must continue to meet the Independence Criteria throughout the duration of such appointment and shall immediately report to the Chairman any actual and/or potential failure to comply therewith. The Chairman and/or his nominee may conduct an investigation into compliance with the Independence Criteria which may also result in disciplinary and/or other action.

### **10.3 Terms of Office of the Executive Committee**

- 10.3.1 In accordance with Bye-Law 9.6.2, the Chairman and Vice-Chairman shall serve on the Executive Committee for a period of four (4) years. The other Members of the Executive Committee (save the Chief Executive Officer) shall be eligible to serve as a Member of the Executive Committee for a period of four (4) years.

The other Members of the Executive Committee (save the Chief Executive Officer) shall be elected and/or approved, as applicable, usually but not necessarily at the Annual Meeting immediately following the quadrennial men's Rugby World Cup Tournament and for a period of four (4) years commencing on July 1 of the same calendar year. The Members of the Executive Committee, including the Vice-Chairman, elected from the Representatives by the Council shall only be entitled to remain Members of the Executive Committee if they remain Representatives on the Council as appointed by their respective Union or Association. Subject to the foregoing as applicable, Members of the Executive Committee may be re-elected and/or re-approved for a further period of membership of the Executive Committee up to a maximum of twelve years in aggregate.

The Chief Executive Officer shall remain a Member of the Executive Committee for the duration of his tenure.

- 10.3.2 Should a vacancy occur on the Executive Committee, subject to Bye-Law 9.6.1(f), the Chairman shall appoint a replacement on an interim basis until the position can be formally filled at the next Council meeting subject to the following:
- (a) where the vacancy relates to one of the seven Representatives, the Chairman shall appoint a replacement from the Representatives; and



- (b) where the vacancy relates to one of the two Independent Members, the Chairman shall appoint a replacement who has been proposed by the Nominations Committee.

The person filling the vacancy following such Council meeting shall be a member of the Executive Committee until the term of the Executive Committee ceases as set out in Bye-Law 10.3.1 or, as applicable.

#### **10.4 Roles, Powers and Responsibilities of the Executive Committee**

The roles, powers and responsibilities of the Executive Committee shall be:

- (a) The formulation and implementation, in conjunction with management, of the mission, strategic goals and plans of World Rugby subject to ratification by Council;
- (b) The approval of the annual business plan and budgets;
- (c) The monitoring of the implementation of the mission, strategic goals and plans and annual business plan, operational plan and budgets of World Rugby and assessment of performance against key performance indicators;
- (d) The appointment of persons to, and removal of persons from, Standing Committees, advisory groups and working parties and the supervision of such Standing Committees, advisory groups, working parties and World Rugby trading companies, excluding Rugby World Cup Limited and its associated entities subject to paragraph (e) below. The Executive Committee shall receive reports from the Rugby Committee and Regulations Committee in relation to proposed Law and Regulation changes respectively, upon which it may comment to Council without amending the recommendations of the relevant Standing Committee in this respect only;
- (e) The appointment of persons to, following proposals from the Nominations Committee, and removal of persons from, the Board of Rugby World Cup Limited. The Board of Rugby World Cup Limited shall be accountable to the Executive Committee and the Executive Committee shall receive reports from the Board of Rugby World Cup Limited but for the avoidance of doubt the Executive Committee shall have no power to overrule any decision of the Board of Rugby World Cup Limited;
- (f) The formulation and implementation of good corporate governance principles and practices;
- (g) To ensure that World Rugby operates as an effective business and member services organisation;
- (h) To appoint a firm of chartered accountants to conduct the audit for the ensuing year;

- (i) To recruit, remove, monitor, evaluate performance and determine delegations of authority and accountabilities of the Chief Executive Officer;
- (j) To approve expenditure, contracts and commitments that fall outside the authority of the Chief Executive Officer;
- (k) To ensure that there is a sound system of internal control and risk management policy and process in place to identify and manage risk;
- (l) To ensure that appropriate codes and policy frameworks exist to promote effective governance of World Rugby through clear written and regular review and updating of:
  - (i) The policies of World Rugby;
  - (ii) Strategic, business and annual operational plans;
  - (iii) Standing orders and terms of reference for committees and advisory groups;
  - (iv) Procedures and protocols for the operation of World Rugby Companies excluding Rugby World Cup Limited and its associated entities;
  - (v) Clearly defined and delegated powers/limits of authority for decision making for the Executive Committee, Standing Committees and staff;
  - (vi) Risk and audit policies (including without limitation through the Audit and Risk Committee established pursuant to Bye-Law 11);
  - (vii) Standard operating policies and procedures;
- (m) Between Council Meetings, to deal with any emergency matters pursuant to Bye-Law 12;
- (n) Subject to paragraph (m) above, to discharge such other responsibilities that do not fall within the constitutional, legal or statutory jurisdiction of the Council or other person/entity under the Bye-Laws required to ensure the effective management and operation of World Rugby;
- (o) To receive and approve the audited financial statements of the Company for the preceding financial year;
- (p) To suspend a Union or Association from membership of World Rugby in accordance with Bye-Law 14(c);
- (p) To approve World Rugby Medical Policy. The Chief Medical Officer shall have the right to attend and address Executive Committee

---

meetings in relation to medical matters and to raise such issues as he thinks fit for consideration by the Executive Committee;

- (q) To determine the Host Union(s) for all World Rugby tournaments save for Rugby World Cup Tournaments (Men's, Women's and Sevens);
- (r) To approve the International Matches and Tours Schedule.

**10.5 Meetings of the Executive Committee**

- 10.5.1 The Executive Committee shall meet in person at least twice per year and at such other times as appropriate in person or utilising technology.
- 10.5.2 Decisions of the Executive Committee shall be taken by simple majority, each Member of the Executive Committee having one vote and in addition the Chairman also having a casting vote in addition to his deliberative vote.



## **BYE-LAW 11. STANDING COMMITTEES**

### **11.1 Establishment of Standing Committees**

11.1.1 Subject to the transitional provisions set out in Bye-Law 16, the Executive Committee will establish five Standing Committees namely:

- (i) The Rugby Committee;
- (ii) The Regulations Committee;
- (iii) The Audit and Risk Committee;
- (iv) The Regional Committee; and
- (v) The Nominations Committee.

11.1.2 The Executive Committee may appoint any person, including without limitation Representatives, to the Rugby Committee, Regulations Committee and Audit and Risk Committee. The composition of the Nominations Committee shall be in accordance with Bye-Law 11.6 below.

11.1.3 In addition to the Other Committees as set out in Bye-Law 13, Standing Committees may establish sub-committees, advisory groups and working groups for specific purposes and subject to the approval of the Executive Committee.

11.1.4 The terms of reference of each Standing Committee shall be determined by the Executive Committee from time to time.

### **11.2 Rugby Committee**

11.2.1 The Executive Committee shall appoint a Chairman of the Rugby Committee who shall be a Representative.

### **11.3 Regulations Committee**

11.3.1 The Executive Committee shall appoint a Chairman of the Regulations Committee who shall be a Representative.

### **11.4 Audit and Risk Committee**

11.4.1 The Executive Committee shall appoint a Chairman of the Audit and Risk Committee who shall be a Representative.

### **11.5 Regional Committee**

11.5.1 The Executive Committee shall appoint a Chairman of the Regional Advisory Committee who shall be a Representative.

## 11.6 Nominations Committee

- 11.6.1 The Executive Committee shall appoint an independent person, who shall be one of the Independent Members of the Executive Committee to be the independent Chairman of the Nominations Committee (subject to Bye-Law 11.6.5).
- 11.6.2 The Nominations Committee shall comprise three further members (subject to Bye-Law 11.6.5):
- (a) The Chairman;
  - (b) An Independent Member; and
  - (c) A Representative from the Executive Committee elected by the Executive Committee.
- 11.6.3 The roles, powers and responsibilities of the Nominations Committee shall be:
- (a) To identify and propose to Council Independent Members for membership of the Executive Committee;
  - (b) To identify and propose to the Executive Committee persons for appointment to Standing Committees, advisory groups and working parties;
  - (c) To identify and propose to the Executive Committee Representatives for appointment as Chairmen of Standing Committees;
  - (d) In consultation with the Chairman of the relevant Standing Committee, to draft job specifications for members of such Standing Committee for approval by the Executive Committee and, where requested by the Executive Committee, to shortlist and interview candidates for membership of Standing Committees and provide reports and recommendations to the Executive Committee;
  - (e) To identify and propose to the Executive Committee persons for appointment to the Board of Rugby World Cup Limited; and
  - (f) In consultation with the Chairman of the Board of Rugby World Cup Limited, to draft job specifications for members of the Board of Rugby World Cup Limited for approval by the Executive Committee and, where requested by the Executive Committee, to shortlist and interview candidates for membership of such Board and provide reports and recommendations to the Executive Committee.
- 11.6.4 Members of the Nominations Committee shall be appointed to such role for a period of four years, subject to the Executive Committee's right to remove any member and/or such member no longer meeting the applicable criteria set out in Bye-Law 11.6.1 and/or 11.6.2, which may be renewed for a further [one/two/etc.] period[s] by the Executive Committee. In the event of the

retirement, resignation and/or incapacitation of any member of the Nominations Committee between Executive Committee meetings the remaining members of such Nominations Committee shall continue to fulfil their obligations pursuant to these Bye-Laws subject to any alternate direction of the Executive Committee. The Executive Committee shall appoint a replacement for any such former member of the Nominations Committee in accordance with these Bye-Laws at its earliest convenience and such replacement shall serve the remainder of the term of the member who he is replacing.

**11.6.5** For transitional purposes:

- (a) The Executive Committee constituted under the Previous Bye-Laws shall appoint Initial Independent Delegates to fulfil the roles of the initial independent Chairman pursuant to Bye-Laws 11.6.1 and/or 11.6.2(b). For the purposes of these Bye-Laws, Initial Independent Delegates, independent Chairman and Independent Members shall be read interchangeably with respect to the initial Nominations Committee.
- (b) The Executive Committee constituted under the Previous Bye-Laws shall appoint a member of that Executive Committee to the initial Nominations Committee pursuant to Bye-Law 11.6.2(c).
- (c) In the event that the Initial Independent Delegates appointed as the Independent Member pursuant to the transitional provisions set out in this Bye-Law 11.6.5 is not appointed as an Independent Member on the first occasion of the exercise of Bye-Law 10.2.5 and/or if the Executive Committee member appointed pursuant to Bye-Law 11.6.5(b) ceases to be a member of the Executive Committee such person(s) shall cease membership of the Nominations Committee at such time and the Executive Committee shall appoint replacement(s) in accordance with these Bye-Laws at its earliest convenience.





---

**BYE-LAW 12. EMERGENCY DECISIONS****12.1 Power of Executive Committee to make emergency decisions**

12.1.1 Between Council Meetings, the Executive Committee may deal with any emergency matters or otherwise matters of an urgent nature that would ordinarily be dealt with by Council under Bye-Law 9.4 in accordance with the procedure set out in this Bye-Law 12 (excluding changes to the Bye-Laws).

12.1.2 Decisions taken by the Executive Committee pursuant to this Bye-Law 12 shall only have effect until the next Council meeting at which the Executive Committee shall report to the Council with respect to the emergency or urgent nature of the matter and the decision taken. Council may ratify the decision or substitute its own decision in its discretion save that where any decision being ratified relates to a change of the Laws or Regulations such decision would require the minimum number of votes from Council as applicable pursuant to Bye-Law 9.7.

**12.2 Emergency decisions which do not require a change of Law or Regulation**

The Executive Committee may make decisions in relation to any emergency and/or urgent matter that would ordinarily be within the purview of Council under Bye-Law 9.4 (excluding changes to the Bye-Laws, Laws or Regulations) as it sees fit by simple majority.

**12.3 Emergency decisions which require a change of Law**

Subject to Bye-Law 5(c) and (d), the Executive Committee may make decisions in relation to any genuine emergency and/or urgent matter which relates to a Law(s) which cannot properly be held over until the next Council meeting and which have the support of each of the Chairman, the Rugby Committee Chairman and the Chief Executive and a three-quarters majority of the Executive Committee.

**12.4 Emergency decisions which require a change of the Regulations Relating to the Game**

The Executive Committee may make decisions in relation to any genuine emergency and/or urgent matter which relates to a Regulation(s) Relating to the Game which cannot properly be held over until the next Council meeting and which have the support of each of the Chairman, the Regulations Committee Chairman and the Chief Executive and a three-quarters majority of the Executive Committee.

**12.5 Emergency decisions which require a change of the General Regulations**

The Executive Committee may make decisions in relation to any genuine emergency and/or urgent matter which relates to a General Regulation(s)

which cannot properly be held over until the next Council meeting and which have the support of each of the Chairman, the Regulations Committee Chairman and the Chief Executive and a simple majority of the Executive Committee.

---

## **BYE-LAW 13. OTHER COMMITTEES**

### **13.1 Establishment of Other Committees**

13.1.1 Subject to the transitional provisions set out in Bye-Law 16, at its first opportunity following the Effective Date, the Executive Committee and/or Standing Committees with the approval of the Executive Committee will establish Other Committees from time to time which will include:

- (i) The Women's Rugby Advisory Committee;
- (ii) The Anti-Doping Advisory Committee;
- (iii) The Rugby Athlete's Commission;
- (iv) The Budget Advisory Committee; and
- (v) The Laws Clarification Group.

The Other Committees shall have such remit and terms of reference as set out in this Bye-Law 13 or as otherwise approved by the Executive Committee. The Other Committees shall meet with such frequency as approved by the relevant Committee to whom they report.

### **13.2 Women's Rugby Advisory Committee**

13.2.1 Following a recommendation from the Nominations Committee after consultation with the Chairman of the Rugby Committee, the Rugby Committee shall appoint the members of the Women's Rugby Advisory Committee including a Chairman who shall be a Representative who is also a member of the Rugby Committee. Such appointments shall be confirmed annually

13.2.2 The Women's Rugby Advisory Committee shall report to the Rugby Committee and is responsible for the supervision of, and recommendations in relation to, the women's rugby strategy as formulated by the Rugby Committee.

### **13.3 Anti-Doping Advisory Committee**

13.3.1 Following a recommendation from the Nominations Committee after consultation with the Chairman of the Regulations Committee, the Regulations Committee shall appoint the members of the Anti-Doping Advisory Committee including a Chairman who shall be a Representative who is also a member of the Regulations Committee. Such appointments shall be confirmed annually.

13.3.2 The Anti-Doping Advisory Committee shall report to the Regulations Committee.

**13.4 Rugby Athlete's Commission**

13.4.1 The Rugby Committee shall appoint the members of the Rugby Athlete's Commission in accordance with the composition confirmed by Council including a Chairman who shall be a Representative, who is also a member of the Rugby Committee. Such appointments shall be confirmed annually.

13.4.2 The Athlete's Commission shall report to the Rugby Committee.

**13.5 Budget Advisory Committee**

13.5.1 The Executive Committee shall appoint the members of the Budget Advisory Committee including a Chairman who shall be a Representative.

13.5.2 The Budget Advisory Committee shall report to the Executive Committee.

**13.6 Laws Clarification Group**

13.6.1 The Rugby Committee shall appoint the members of the Laws Clarification Group including a Chairman who shall be a Representative who is also a member of Rugby Committee. Such appointments shall be confirmed annually.

13.6.2 The Laws Clarification Group shall report to the Rugby Committee.

---

**BYE-LAW 14. MEMBERSHIP**

- (a) Membership of World Rugby is open to National Rugby Unions based in a country where such Unions are solely responsible for governing Rugby's sporting, technical and general organisation and implementation of all rugby related matters and which meet the World Rugby Membership Pathway and Membership Criteria established by Council from time to time and set out in detail at [www.worldrugby.org](http://www.worldrugby.org).
- (b) Unions must ensure that elections to their governing body(ies) take place pursuant to a free and independent democratic process which conforms with applicable national legislation and the requirements of the Common Association Constitution.
- (c) A Union or Association may be suspended (but not expelled) from World Rugby membership or reverted to associate membership status by the Executive Committee as an interim measure pending the next meeting and decision of Council (taken in accordance with Bye Law 14(d) below) for any reason that the Executive Committee determines is appropriate.
- (d) A Union or Association may be expelled or suspended from World Rugby membership or reverted to associate membership status (temporarily or on a permanent basis) by Council for any reason that Council determines to be appropriate provided that it is supported by a majority of at least three quarters of the Representatives present at the Council meeting.
- (e) A Union may be suspended or expelled from World Rugby membership pursuant to World Rugby Bye-Laws and/or Regulations if state authorities interfere in its affairs in such a manner that:
  - (i) it may no longer be considered as fully responsible for the organisation of rugby related matters in its territory;
  - (ii) in the opinion of Council or the Executive Committee it is no longer in a position to perform its constitutional and regulatory tasks in an appropriate manner.



---

**BYE-LAW 15. INTERPRETATION**

- (a) In the event of a doubt arising at any time on a matter not provided for in, or as to the meaning or construction of the Bye-Laws, the Council shall be requested to determine the same.
- (b) These Bye-Laws and any Regulations Relating to the Game, General Regulations or Laws of the Game made pursuant thereto shall in all respects be governed by and construed in accordance with English Law, and any dispute arising there under shall be subject to the exclusive jurisdiction of the English Courts.
- (c) English shall be the official language of World Rugby.
- (d) Unless the context otherwise requires in these Bye-Laws the masculine gender shall include the feminine gender and the singular shall include the plural and vice versa.







**WORLD  
RUGBY™**

# SECTION 3

## REGULATIONS RELATING TO THE GAME



## SECTION 3      Regulations Relating to the Game

Contents	73
1. Definitions	75
2. Compliance with Regulations	77
3. Domestic Regulations	83
4. Player Status, Player Contracts and Player Movement	87
5. Agents	89
6. Anti-Corruption and Betting	121
7. Appearances, Communications, Advertising and Sponsorship	123
8. Eligibility to Play for National Representative Teams	149
9. Availability of Players	151
10. Medical	175
11. Advertising Within the Playing Enclosure	197
12. Provisions Relating to Players Dress	201
13. Broadcasting Rights	211
14. Ownership of Clubs	255
15. International Matches	257
16. Organisation of International Matches; International Tournaments; International Tours	259

....

17. Discipline – Foul Play	269
18. Disciplinary and Judicial Matters	323
19. Mediation	341
20. Misconduct and Code of Conduct	343
21. Anti-Doping	357
Schedule 1. Doping Control Procedural Guidelines	455
Schedule 2. WADA Prohibited List	477
Schedule 3(a). WADA International Standard for Therapeutic Use Exemptions (TUE)	487
Schedule 3(b). World Rugby TUE Application Form	501
Schedule 4. Acknowledgements and Agreement Form	503
Schedule 5. Player Information Notice–Data Privacy	505
22. Artificial Playing Surfaces	509
23. Insurance	517
24. Matters Not Provided For	521

## REGULATION 1. DEFINITIONS

1.1 For the purposes of these Regulations the terms below shall have the following meanings assigned to them unless the context otherwise requires.

**Age of Majority** is deemed to be acquired on a Person's 18th birthday.

**Agent** means an agent or adviser acting on behalf of a Person, Union, Rugby Body or Club in relation to that Person's, Union's, Rugby Body's or Club's activity in the Game.

**Appeal Committee** has the meaning given to it in Regulation 18.3.

**Appeal Panel** means a panel of individuals from which Appeal Committees may be selected in accordance with Regulation 18.3.

**Appeal Tribunal** has the meaning given to it in Regulation 17.6.

**Association** means an association of Unions recognised by the Council.

**Broadcasting Rights** has the meaning given to it in Regulation 13.1.

**Bye-Laws** means the Bye-Laws for the time being adopted by World Rugby and in force.

**CEO** means Chief Executive Officer of World Rugby appointed by the Council.

**Citing Commissioner** has the meaning given to it in Regulation 17.13.1(a).

**Clearance** means the written consent (in the standard form) authorising a Player to participate in the Game in a New Union at the request of such New Union and signed by:

- (a) the Player's Current Union;
- (b) the Union for whom the Player plays International Matches where such Player has represented that Union in a Match covered by Regulation 8.3 or 8.4;
- (c) the New Union.

**Contract Player** has the meaning given to it in Regulation 4.5.7.

**Core (mandatory) Concussion Player Welfare Standards** means the standards that apply to access temporary replacement to undertake a HIA which are contained in the HIA Protocol. The Protocol is available for elite level match day medical staff [here](#).

**Council** means World Rugby's Executive Council which comprises representatives of Unions and Associations appointed as provided in the Bye-Laws and which manages and controls the affairs of World Rugby.

**Club** means a body or organisation affiliated directly or indirectly to a Union.

**Cross-Border Matches** means Matches between teams from different Unions below National Representative Team level organised under the jurisdiction of a Union or recognised Tournament Organiser or other Rugby Body.

**Current Union** means the Union with which a Player is Registered.

**Designated Release Events** means Union Designated Release Events and Combined Teams Designated Release Events.

**Disciplinary Committee** has the meaning given to it in Regulation 17.

**Disciplinary Officer** means the person appointed by World Rugby on its behalf to investigate, present and enforce (as appropriate) World Rugby Regulations and to administer in particular Regulations 6 (Wagering), 17 (Discipline – Foul Play) and 20 (Misconduct).

**Disciplinary Tribunal** means any appointed Judicial Officer, Judicial Committee, Disciplinary Committee, Appeal Officer and/or Appeal Committee.

**Dual Registration** means registration with two Unions in the circumstances permitted under Regulation 4.5.8 and 4.5.9.

**Game** means rugby football played in accordance with the Laws of the Game.

**GRTP Programme** means the Graduated Return To Play programme of World Rugby (contained in the World Rugby Concussion Guidance), which incorporates a progressive exercise programme that introduces a player safely back to the sport in a step-wise fashion. The programme is available [here](#).

**HIA Protocol** means the Head Injury Assessment Protocol of World Rugby developed to support Law 3.11 (Temporary Replacement for Head Injury Assessment in elite adult matches, which have been approved in advance by World Rugby) and Regulation 10.1 (Concussion). The Protocol is available for elite level match day medical staff [here](#).

**Host Union** means the Union under whose jurisdiction an International Match is played.

**Home Ground** has the meaning given to it in Regulation 2.1.4.

**Home Union** means the Union with which a Player is or was first Registered, or, if different, the Union where a Player was trained or developed.

**International Match** means any match played between National Representative Teams selected by Unions whether at 15-a-side or an abbreviated version of the Game.

**International Tournament** means a tournament in which teams representing Unions at any level meet to participate in a Series of Matches whether at 15-a-side or an abbreviated version of the Game.

**International Tour** means a Match or Series of Matches in which a team representing a Union at any level participates against a National Representative Team and/or other Rugby Bodies or Clubs in the jurisdiction of another Union.

**IOC** means the International Olympic Committee being an association created by the Congress of Paris of June 1894 and which is entrusted with the control and development of the Modern Olympic Games pursuant to the Olympic Charter.

**Judicial Committee** has the meaning given to it in Regulation 18.2.

**Judicial Officer** has the meaning given to it in Regulation 17.3.1(c).

**Judicial Panel** means a panel of individuals from which Judicial Officers and Judicial Committees may be selected in accordance with Regulation 18.2.

**Match** means a Game in which two teams compete against each other.

**Material Benefit** means money, consideration, gifts or any other benefits whatsoever promised or given to a Person or any other individual, body corporate, partnership (or any other entity or body whether incorporated or not) at his direction in respect of such Person's participation in the Game, but shall not include bona fide reimbursement of expenses incurred for reasonable travel, accommodation, subsistence or other expenses incurred solely and directly in relation to the Game.

**Match Official** means a referee and/or a touch judge and shall include, when appointed, a Citing Commissioner and/or the fourth official.

**Minor** shall mean a person who has not reached the Age of Majority as referred to in World Rugby Regulations

**National Olympic Committee** means the body recognised by the International Olympic Committee as having responsibility within their respective territories for developing, promoting and protecting the Olympic movement in accordance with the Olympic Charter.

**National Representative Team** means a team selected by a Union to represent that Union.

**National Squad** means the group of Players (of any number) selected by a Union from time to time from which Players may be nominated to represent that Union's two senior National Representative Teams.

**New Union** means the Union with which a Player wishes to become Registered.

**Non-Contract Player** has the meaning given to it in Regulation 4.5.7.

**Olympic Charter** means the codified document which embodies the fundamental principles of Olympism, the rules and bye-laws of the International Olympic Committee and which governs the organisation, action and operation of the Olympic movement and sets out the conditions for the celebration of the Olympic Games.

**Olympic Events** means those events set out in Regulation 8.6 and Schedule 2 to Regulation 8 (reflecting the current Olympic cycle).

**Person** means a Player, trainer, referee, touch judge, coach, selector, medical officer, physiotherapist or any other individual who is or has been at any time involved in the Game, or in the organisation, administration or promotion of the Game.

**Player** means a player of the Game who is a Non-Contract Player or a Contract Player.

**Registered/Registration** means registered with a Union, whether directly, or indirectly via registration with a Club or other Rugby Body affiliated to such Union.

**Regulations** means Regulations Relating to the Game binding on all Unions and Associations and which have been passed by the Council or which may hereafter be passed by the Council under the powers contained in the Bye-Laws.

**Regulations Committee** means the Committee appointed pursuant to Regulation 2.2.

**Residence** means the place or location in which a Player has his primary and permanent home and Resident shall be construed accordingly.

**Rugby Body** means a provincial union, district, state, group of Clubs, Tournament Organiser, or similar organisations, recognised by and/or affiliated directly or indirectly to a Union.

**Series of International Matches** means two or more Matches at International level played between National Representative Teams selected by Unions.

**Series of Matches** means two or more Matches.

**Standard Dual Registration Forms** means the standard form used by a Student and/or Serviceman's Home Union to permit the Student or Serviceman to register with a second Union pursuant to Regulations 4.5.8 and 4.5.9.

**The British and Irish Lions** means "The Lions – A team comprising of Players selected from England, Ireland, Scotland and Wales".

**The Combined Team of the Pacific Island Unions** means a combined team comprising of Players selected from the Pacific Island Unions of Fiji, Samoa and Tonga.



**Tournament Organiser** means any entity that arranges, organises and has administrative responsibility for a tournament or Series of Matches (whether international or below international level). The Tournament Organiser must be recognised as such by the Union(s) in whose territories the relevant tournament or Series of Matches are played and/or whose affiliated teams or National Representative Teams participate in such tournament or Series of Matches.

**Tours Agreement** means the agreement approved by the Council which provides for the terms under which a Union visits another Union or Unions.

**Union(s)** means every national rugby Union for the time being in membership of World Rugby.

**World Rugby** means World Rugby, being the association of Unions or Associations in membership of World Rugby in accordance with the Bye-Laws, formerly known as the International Rugby Board.

**World Rugby Sevens Tournament** means the Rugby World Cup Sevens (Finals and Qualifying Matches), the World Sevens Series and such other Sevens Tournaments that World Rugby shall from time to time designate.

- 1.2 Unless the context otherwise requires in these Regulations the masculine gender shall include the feminine gender and the singular shall include the plural and vice versa.
- 1.3 In these Regulations, reference to a Law is a reference to a Law of the Game.
- 1.4 In the event of any inconsistency between the Council's Tours Agreement and these Regulations, these Regulations shall prevail.
- 1.5 In the event of any inconsistency between the Laws of the Game and these Regulations, the Laws of the Game shall prevail.
- 1.6 In these Regulations, reference to the secretary of a Union shall include the Chief Executive Officer appointed by a Union or such other person acting in a similar capacity and vice versa.
- 1.7 These Regulations shall be interpreted in accordance with Regulation 2.1.6.



## REGULATION 2. COMPLIANCE WITH REGULATIONS

### 2.1 Compliance

2.1.1 A Union or Association is deemed to have full knowledge of the content of these Regulations.

A Union or Association must ensure that it complies with these Regulations and must further ensure that it takes appropriate action to inform each and every one of its members of the terms of the Regulations and the obligation to comply with the same. World Rugby may from time to time issue guidelines in relation to the implementation of these Regulations. Any breach(es) of such guidelines may render a Union, Rugby Body, Club or Person responsible for such breach(es) liable to sanctions.

A Person must ensure that he complies with the World Rugby Code of Conduct and Players must ensure that they comply with Regulation 8. Breaches of these provisions will be dealt with in accordance with Regulation 18.

2.1.2 A Club or Rugby Body may only be affiliated to one Union and shall be subject to the jurisdiction of the bye-laws, rules and regulations of that Union. A Club or Rugby Body may only be affiliated to the Union within whose geographical boundaries its Home Ground is situated and shall only be entitled to play in Matches organised, recognised or sanctioned by that Union, unless specific approval has been given by both Unions. No Club or Rugby Body shall be entitled to change the location of its Home Ground or the name by which its senior teams are known, without the prior written consent of the Union to which it is affiliated.

2.1.3 A Club or Rugby Body that wishes to change its Home Ground to a location outside of the geographical boundaries of the Union to which it is affiliated must, before taking any steps to effect such a change, obtain written permission from the secretary of the Union to which it is affiliated, who in turn, subject to permission being granted by his Union, will seek the agreement of the secretary of the other Union.

2.1.4 For the purposes of Regulations 2.1.4 and 2.1.5, Home Ground shall mean the ground within the geographical boundaries of the Union to which the Club or Rugby Body is affiliated, at which the Club or Rugby Body's senior team plays its home fixtures and which is approved by the Union to which the Club or Rugby Body is affiliated.

2.1.5 A Union may consent or direct that a Club plays a home fixture at a ground other than its Home Ground, provided such ground is within the geographical boundaries of the Union.

2.1.6 These Bye-Laws and any Regulations Relating to the Game, General Regulations or Laws of the Game made pursuant thereto shall in all respects be governed by and construed in accordance with English Law,

and save as otherwise provided herein, any dispute arising thereunder shall be subject to the exclusive jurisdiction of the English Courts.

## **2.2 Regulations Committee**

2.2.1 The Council shall appoint on an annual basis a committee of representatives (“the Regulations Committee”) from Unions and/or Associations represented on the Council. The Regulations Committee shall rule on matters of interpretation and/or implementation of these Regulations referred to it by the CEO. The quorum of the Committee shall be three. Upon referral of a matter to it the Committee shall be entitled to regulate its own procedures save that the rulings of the Committee shall be made by majority.

2.2.2 In the event of any dispute or uncertainty in respect of the interpretation or implementation of these Regulations, a Union or Association may make a written request for clarification to the CEO. On receipt of such a request, the CEO must (1), whether personally or through a designee attempt to resolve the dispute or uncertainty by a ruling to the satisfaction of the parties concerned; or (2) refer the matter to the Regulations Committee for a ruling; or (3) refer the matter to a Judicial Officer or Judicial Committee for adjudication under Regulation 18.2(d). If the CEO or his designee fails to resolve the dispute or uncertainty to the satisfaction of the parties within 28 days of receipt of the request, the CEO shall refer the matter to the Regulations Committee in accordance with (2) above or to a Judicial Officer or Judicial Committee in accordance with (3) above.

2.2.3 Any ruling made by the Regulations Committee, the CEO or his designee shall, be intimated in writing to the Union or Association concerned giving full reasons for the Committee or CEO or designee’s decision or ruling as soon as it is made, subject to any appeal under 2.2.4 below bind all Unions and Associations unless and until otherwise determined at a meeting of the Council.

### **2.2.4 Appeals**

A Union/Association which has been the subject of a decision or ruling by the Regulations Committee or by the CEO shall have the right of appeal against such a decision to the Council of World Rugby (which body for this appeal hearing may not include any member of the Regulations Committee which heard the original matter), but only if a Notice of Appeal is lodged with the CEO within 14 days of receipt of notification by the Union or Association of the decision of the Regulations Committee.

### **2.2.5 Appeals arising from Regulation 8.7**

A Union and/or Player who has been the subject of a decision by the Regulations Committee in respect of Olympic eligibility shall have the right of appeal against such decision to the Eligibility Appeals Committee, if a Notice of Appeal is lodged with the CEO within 14 days of receipt of notification by the Union and/or Player of the decision of the Regulations Committee.

---

The Olympic Eligibility Appeals Committee shall comprise of three persons selected by the Judicial Panel Chairman in consultation with the World Rugby Chairman. The Chairman of the Eligibility Appeals Committee shall be a lawyer of at least 10 years standing or a serving or retired judge with previous experience in sports eligibility proceedings and/or sports arbitration and two other members drawn from the World Rugby Judicial Panel and/or World Rugby Standing Committees and/or other legally qualified persons with previous experience in sports arbitration proceedings, provided such persons are neutral of the Union(s), Player(s) or parties concerned.



---

### REGULATION 3. DOMESTIC REGULATIONS

Provided that the same are not in conflict with these Regulations and subject to conformity with the relevant legal systems a Union may make and adopt other more restrictive regulations. Such domestic regulations shall have effect only within the jurisdiction of that Union.





### **REGULATION 4. PLAYER STATUS, PLAYER CONTRACTS AND PLAYER MOVEMENT**

- 4.1** The Game is open to all and Persons may receive Material Benefit notwithstanding that for the majority of those participating in the Game will remain a non-vocational leisure activity.
- 4.2** The provisions of this Regulation 4 deal with the status and eligibility of Players and the movement of Players from one Union to another.
- 4.3** Subject to Regulation 4.4 below, each Union shall provide its own system for the movement of Players within its jurisdiction. Such system shall be governed by appropriate regulations and shall be provided to World Rugby on request.
- 4.4** The regulations referred to in Regulation 4.3 above shall include the Regulations and observe the general principles set out in Regulations 4.5, 4.8.1 and 4.9 below.
- 4.5** **Status of Players and Contracts for Material Benefit**
- 4.5.1** Subject to Regulation 4.5.10:
- (a) a Player may receive Material Benefit from a Union;
  - (b) a Union may permit any Rugby Body or Club in membership of that Union to provide Material Benefit to any Player;
  - (c) any Player receiving Material Benefit from a Union, Rugby Body or Club must have in place a written agreement with such Union, Rugby Body or Club.
- 4.5.2** If a Union grants such permission as is referred to in 4.5.1 (b) above, then prior to any written agreement between a Rugby Body or Club and a Player taking effect within that Union, the written agreement must:
- (a) be agreed by the relevant parties;
  - (b) be concluded for a pre-determined period; and
  - (c) be in a form approved by the Union as notified in writing to the Rugby Body or Club.
- A copy of such written agreement shall be provided to the Union concerned and, on demand, made available to World Rugby.
- 4.5.3** Only written agreements (excluding financial terms) in a form approved in writing and distributed by the Union within whose territory the Player is Registered shall be used by Rugby Bodies and/or Clubs and recognised by the Union and/or World Rugby.
- 4.5.4** Only Players with written agreements that are in a form approved and distributed by the Union concerned shall be eligible to participate in competitions organised, recognised or sanctioned by that Union.

- 4.5.5 No Union, Rugby Body or Club shall enter in any written agreement and/or arrangement of any kind that provides for and/or in any way facilitates third party influence and/or control over a Player's playing relationship with his Union, Rugby Body or Club and/or his Registration.
- 4.5.6 Only a Player who is currently Registered with a Union shall be able to participate in competitions organised, recognised or sanctioned by that Union<sup>1</sup>.
- 4.5.7 Players who are Registered and are currently receiving, or who have received, Material Benefit shall be regarded as Contract Players (save for those Players who are no longer classified as Contract Players in accordance with the provisions of Regulation 4.8.1 below). All other Players who are Registered shall be regarded as Non-Contract Players.
- 4.5.8 A Player may not be registered simultaneously with more than one Union unless he is classified as a student that has reached the age of majority and is in full time education ("Student") or has reached the age of majority and is a full time member of the armed services ("Serviceman") and has the prior written permission of his Home Union for Dual Registration<sup>2</sup>. The status of a Player shall be determined by the Home Union of the Student and/or Serviceman.
- 4.5.9 For the purposes of Regulation 4.5.8, the Home Union of the Player has absolute discretion to refuse a Student or Serviceman (as the case may be) permission for Dual Registration. Only players that are Students or Servicemen are entitled to apply for permission for Dual Registration. Where a Student or Servicemen is granted permission for Dual Registration by their Home Union:
- (a) The Dual Registration will not amount to a Clearance under Regulation 4.6 and must be:
    - (i) For no longer than twelve months;<sup>3</sup> and
    - (ii) By way of a Standard Dual Registration Form.

---

<sup>1</sup> In respect of the lowest levels of its competitive structure only, a Union or Association may make a written application to the CEO for approval not to apply Regulation 4.5.6. A Union or Association must set out, in full, the reasons for the application and shall provide such further information. Documents and/or any other assistance that the CEO may deem necessary for the proper consideration of the application. The CEO shall have absolute discretion in relation to the approval or refusal of any such application by a Union or Association and the decision of the CEO, including, but not limited to any conditions of approval, shall be final and binding. The CEO may at his absolute discretion withdraw any approval granted to any Union or Association pursuant to this provision. For the avoidance of doubt, any application made pursuant to this provision shall only be considered by the CEO if it relates to the lowest levels of a Union or Association's competitive structures. Disputes arising out of Regulation 4 will, preferably, be adjudicated on by member(s) of the Judicial Panel who are experienced in player issues, including but not limited to training and development, and may include eminent ex-players.

<sup>2</sup> NB: An attempt has been made to define Student and Servicemen narrowly. Operational experience will demonstrate whether further refinement to these Regulations is necessary to achieve the underlying purpose of this amendment.

<sup>3</sup> Consideration may need to be given to imposing a limitation on the number of times a Player may apply for Dual Registration. In practice this may present difficulties due to the length of degree courses and uncertainty with regard to Servicemen's tours of duty.

- (b) The Union with which the Player is first Registered retains all rights in relation to the Player concerned including, but not limited to, the right to seek compensation in respect of the Player pursuant to Regulation 4.7.
- 4.5.10 When leaving his Current Union, a Player shall not be treated as a Contract Player unless he was Registered as such with that Union.
- 4.5.11 Each Union shall maintain a register of all Contract Players and all Dual Registered Players under its jurisdiction and shall provide access to and/or copies of such register (or any part thereof) on demand, to World Rugby.
- 4.5.12 No Union, Rugby Body or Club shall enter into an agreement with any Player which enables the Player to receive Material Benefit unless:
- (a) such Player has reached the age of contractual majority within the jurisdiction of such Union, Rugby Body, or Club; or
  - (b) in the case of Players under the age of contractual majority who are aged 16 years or over, unless such Material Benefit takes the form of a non refundable financial grant to be applied only for the purposes of a Player's academic and/or vocational training for a period of 12 months or longer.
- 4.5.13 Each Union is entitled to establish appropriate regulations relating to the registration and development of Players below the age of contractual majority within the jurisdiction of such Union.<sup>4</sup>
- 4.5.14 Any regulations established by a Union pursuant to Regulation 4.5.13 above must be provided to World Rugby on request by World Rugby.

### **4.6 Movement of Players Between Unions**

- 4.6.1 A Player leaving or proposing to leave his Current Union to play in another Union shall not be Registered or eligible to participate in competitions organised, recognised or sanctioned by that New Union until the New Union has received the original version (or a facsimile copy of the original version) of a Clearance.<sup>5</sup>
- 4.6.2 A copy of a Clearance should be provided to World Rugby on request by the New Union and a further copy must remain in the possession of the Player's Current Union.

---

<sup>4</sup> To assist the Unions World Rugby may issue guidelines to Unions on the development and registration of young players.

<sup>5</sup> Clearance means the written consent (in the standard form) authorizing a Player to participate in the Game in a New Union at the request of such New Union and signed by:

- (a) the Player's Current Union;
- (b) the Union for whom the Player plays International Matches where such Player has represented that Union in a Match covered by Regulation 8.3 or 8.4; and
- (c) the New Union.

- 4.6.3 A Player's Current Union shall not consent to the issue of a Clearance if that Player is under suspension on disciplinary grounds, unless such suspension is for a period of five weeks or less and the New Union has confirmed in writing that a suspension for an equal period of the balance of the suspension will be imposed on the Player in the competition(s) for which the New Union is to register him.
- 4.6.4 A Player's Current Union shall be entitled to refuse to give its consent to the issue of a Clearance if the Player concerned has not fulfilled any of his obligations under the terms of his contract with his Current Union, Rugby Body or Club.
- 4.6.5 Save in the circumstances set out in Regulations 4.6.3 and 4.6.4 above, a Player's Current Union shall not be entitled to refuse to give its consent to the issue of a Clearance.
- 4.6.6 A Contract Player's current Union shall indicate on the Clearance the period of rest the Contract Player has received in the preceding 12 months.
- 4.6.7 Disputes relating to the issue of a Clearance shall be referred, by Unions or Associations only, to the CEO who shall, via the Judicial Panel Chairman, or his designee, refer such disputes to a Judicial Officer or Judicial Committee to be dealt with in accordance with Regulation 18.10.

#### **4.7 Compensation for Player Development**

- 4.7.1 A Contract Player shall not move to another Union, Rugby Body or Club during the period of his written agreement unless the Union, Rugby Body or Club to which he is contracted, the Union, Rugby Body or Club he is proposing to join, and the Player himself all concur. Any compensation to be paid in such cases shall be agreed between the relevant parties concerned.
- 4.7.2 In recognition of the investment made by Unions, Rugby Bodies or Clubs (as the case may be) in the training and/or development of Players, when:
- (a) a Contract Player whose written agreement has expired enters into a written agreement for the first time with a Union, Rugby Body or Club outside his Home Union, his Home Union (or Rugby Body or Club in membership of his Home Union as the case may be) shall, be entitled to compensation for his training and/or development;
  - (b) a Non-Contract Player enters into a written agreement for the first time with a Union, Rugby Body or Club outside his Home Union, his Home Union (or Rugby Body or Club in membership of his Home Union as the case may be) shall be entitled to compensation for his training and/or development; and
  - (c) a Non-Contract Player moves outside his Home Union and retains his status as a Non-Contract Player, then, subject to Regulation 4.8.3, the Player's Home Union (or Rugby Body or Club in

membership of his Home Union, as the case may be) shall have no claim to compensation.

4.7.3 Disputes over which Union constitutes a Player's Home Union for the purposes of determining entitlement to compensation for a Player's training and development may be referred, by Unions or Associations only, to the CEO who shall via the Judicial Panel Chairman, or his designee, refer such disputes to a Judicial Officer or Judicial Committee to be dealt with in accordance with the provisions of Regulation 18.10. In determining such entitlement, the Judicial Officer or Judicial Committee shall, in particular, take into account the following factors:

- (a) the length of time the Player trained with the relevant Union, Rugby Body or Club;
- (b) actual training costs incurred by the relevant Union, Rugby Body or Club;
- (c) the quality and regularity of the training undertaken; and
- (d) the progress of the Player during his time at the relevant Union, Rugby Body or Club.

4.7.4 The amount of compensation payable pursuant to Regulation 4.7.2, shall be calculated in accordance with Figure 1 below:

**Figure 1**

$$A = B \times C$$

Where A = the compensation payable;

B = the Standard Annual Development Investment of £5,000<sup>6</sup>;

C = the number of years, between the ages of 17 and 23, a player has spent in development programmes of the Current Union.

For illustrations of the formula see Section 7 of the Explanatory Note to Regulation 4.

4.7.5 The Standard Annual Development Investment figure represents the average level of per Player funding attributable to development programmes in World Rugby High Performance and Performance Unions.

The factors below constitute a guide to what is included within the Standard Annual Development Investment:

- (a) Actual and identifiable training costs in relation to Player development incurred by the Union, Rugby Body or Club (as the case may be) including, but not limited to:

---

<sup>6</sup> The level of Standard Annual Development Investment is subject to annual review of the Regulations Committee.

- (i) proportionate salary or compensation paid to coaches;
  - (ii) board and lodging;
  - (iii) proportionate costs of training infrastructure (for example, hire of facilities, equipment);
- (b) Other general costs that can be attributed, either in full or in part, to a Player's rugby education, training and development; and
- (c) Assembly costs for next senior fifteen-a-side National Representative Team, senior National Representative Sevens Team and National Age Grade Teams.

For the avoidance of doubt, the following items are specifically excluded from the Standard Annual Development Investment:

- (d) Medical and non-rugby specific costs (e.g., school fees and other education costs);
- (e) Domestic and international competition costs; and
- (f) Assembly costs for domestic club teams and international club teams.

4.7.6 The number of years a Player has spent in development programmes of the Current Union is a key component of the calculation. It is recognised that there is a defined period in which Unions invest in Player development, and this is deemed to be between the ages of 17 and 23. During the defined development period therefore, there is a maximum of seven years investment in Player development.

4.7.7 Any disagreement over the fee payable pursuant to Regulation 4.7.2 and Figure 1 for such Player's training and/or development, may be referred, by Unions or Associations only, to the CEO who shall via the Judicial Panel Chairman, or his designee, refer such disputes to a Judicial Officer or Judicial Committee to be dealt with in accordance with the provisions of Regulation 18.10.

4.7.8 Any disagreement between the relevant parties regarding the payment of compensation for the training and/or development of a Player, shall not affect a Player's playing activity and Clearance may not be refused for this reason.

4.7.9 Compensation for a Player's training and development shall be paid by the Rugby Body or Club (as the case may be) to which the Player is proposing to move, to the Player's Home Union.

4.7.10 Each Union shall be entitled to establish its own regulations for the distribution of compensation monies received by it to Rugby Bodies and Clubs in its membership or otherwise.

4.7.11 When compensation for a Player's training and development is payable by a Rugby Body or Club, then the Union with which such Rugby Body or

Club is affiliated shall, in the event of default or non-performance by such Rugby Body or Club be liable for the payment of the compensation as principal debtor.

### **4.8 Change of Player Status**

4.8.1 A Player who has been Registered as a Contract Player will continue to be classified as a Contract Player until a period of 12 months has elapsed from the date such Player competed in his last Match when registered as a Contract Player.

4.8.2 Subject to Regulation 4.7.2(a), if, within three years of the date on which a Contract Player competed in his last Match when registered as a Contract Player, he enters into a written agreement in a different Union, then his Home Union (or Rugby Body or Club in membership of his Home Union) shall be entitled to compensation for his training and/or development.

4.8.3 Subject to Regulation 4.7.2(b) if, within three years of the date on which a Non-Contract Player moves outside his Home Union he enters into a written agreement in a different Union then his Home Union (or Rugby Body or Club in membership of his Home Union, as the case may be) shall be entitled to compensation for his training and/or development.

4.8.4 Prior to a Player's status changing pursuant to Regulation 4.8.2 or 4.8.3 above, the Union to which the Player is about to become Registered shall notify the Player's Home Union.

### **4.9 Approaches to Players**

4.9.1 No Union, Rugby Body, Club, Agent or any other Person or entity, whether acting on its own account or on behalf of any third party, shall induce or attempt to induce any Contract Player or other Person who has a written agreement with a Union, Rugby Body or Club to leave his Union, Rugby Body or Club unless the prior written consent of that Union, Rugby Body or Club has been obtained.

### **4.10 Disputes Personnel**

4.10.1 Disputes arising out of Regulation 4 will, preferably, be adjudicated on by member(s) of the Judicial Panel who are experienced in player issues, including but not limited to training and development, and may include eminent ex-players.

## SECTION 1. GUIDELINES FOR UNIONS ON THE DEVELOPMENT OF YOUNG PLAYERS

### A. Introduction – Mission

To assist Unions in devising programmes for the development and training of young players within their jurisdiction World Rugby has developed Guidelines on the development of young players, incorporating a Young Player Protocol and an Explanatory Note on compensation for young player training and development activities.

In producing the Guidelines the objective of World Rugby is to:

- (i) encourage Unions, Clubs, Rugby Bodies, schools and colleges to attract as many young players as possible to participate in the sport of Rugby Union without prejudice to their educational needs;
- (ii) to encourage the introduction of coaching and training programmes that promote the development of young players; and
- (iii) Reward Unions, Clubs and Rugby Bodies that make a commitment and investment in developing future generations of Rugby Union players.

### B. Integrated Approach

Unions, Clubs and Rugby Bodies should work and liaise closely with schools, colleges and Clubs, at all levels, to ensure that Rugby Union is perceived as a positive experience for potential young players. Unions, Clubs and Rugby Bodies should also work to establish and maintain good relationships with local schools, colleges and community centres to encourage participation and to help minimise the potential for conflict between the interests and activities of school/representative rugby and Club rugby, paying particular regard to the dangers of over-commitment to one activity.

### C. Licensed Training Centres

Unions may operate, and/or sanction, Rugby Bodies or Clubs in their membership to operate, Licensed Training Centres in which young players may receive coaching and training services. Unions should develop application forms to be completed by Rugby Bodies and Clubs in their membership who wish to operate a Licensed Training Centre. The number of Licensed Training Centres in a Union and the conditions pursuant to which permission to run a Licensed Training Centre may be granted by a Union shall be determined by that Union. However, the Fundamental Requirements set out in section D below should be satisfied before a Union may operate and/or sanction a Licensed Training Centre to be operated by a Rugby Body or Club within its jurisdiction.

A Union may only operate, or arrange to have operated, a Licensed Training Centre and/or conduct any other development, training or playing programme within its own geographical boundaries. Rugby Bodies or



Clubs may only operate or arrange to have operated Licensed Training Centres and/or conduct any other development, training or playing programme within the geographical boundaries of the Union to which the Rugby Body or Club is affiliated.

Unions must undertake an annual review of the performance of each Licensed Training Centre within its jurisdiction to determine whether that Training Centre should maintain its status as a Licensed Training Centre. In addition to Licensed Training Centres, Unions should encourage and promote participation in Rugby Union and the development of young players via other means.<sup>7</sup> This may include, but should not be limited to, mini-rugby, junior rugby and age-grade rugby organised by Clubs or Rugby Bodies registered with the Union. Any such matches or related coaching/training activities must be properly regulated to ensure that the health and welfare of young players is properly protected at all times. In this respect Unions should have regard, in particular, to the Fundamental Requirements set out in section D below including, but not limited to:

- (a) implementing proper Child Protection policies that ensure any persons having contact with minors have been properly vetted/ screened to ensure their suitability to participate in playing/training activities involving minors; and
- (b) the provision of appropriate medical and first aid facilities.

#### **D. The Fundamental Requirements**

Licensed Training Centres must:

1. Develop programmes that concentrate not only on physical and technical training and development of young players, but also focus on the broader educational, personal and welfare needs of such players.
2. Ensure that Licensed Training Centre personnel/operatives liaise with parents or legal guardians of young players to design programmes that operate in the best interests of a player's educational, technical, academic and social needs.
3. Aim to provide players with an effective Rugby education having regard to their age and playing capabilities.
4. Develop coaching and training programmes that have as their first priority, the interests of players, in particular, their health, safety and welfare.
5. Ensure that coaching staff, parents (or legal guardians) and players maintain the highest ethical standards at all times and adhere to the World Rugby Young Players' Protocol.
6. Devise and apply effective policies of 'Child Protection'. These policies should include appropriate procedures for the recruitment of qualified

---

<sup>7</sup> Unions should note, however, that only players properly registered as Associate Players in Licensed Training Centres will be covered by the Compensation Scheme set out in section 3 of these Guidelines

- coaches and other adults having contact with minors, based on vetting/screening and registration processes.
7. Engage coaches and adult staff that are well trained and committed to their continuing development as coaches.
  8. Provide suitable, safe facilities for the coaching and development of minors, including proper medical and first aid facilities.
  9. Have readily available during training sessions and/or matches, persons (coaches or others) who are able to administer emergency first aid treatment to young players.
  10. Have in place appropriate insurance cover for all players, coaches and staff engaged in any Licensed Training Centre activity.
  11. Apply effective monitoring schemes designed to ensure that playing and training timetables for young players are properly regulated to avoid overplaying and/or over-training.
  12. Adopt policies that prevent players travelling long distances and/or giving a disproportionate amount of time to training and development programmes to the detriment of the players' academic or other recreational activities.
  13. Ensure that Licensed Training Centre personnel inform parents (or legal guardians), schools and other interested parties how they intend to train and develop a player and seek to ensure that training programmes complement, and do not prejudice, other educational and/or vocational training that the young player is receiving or may receive.
  14. Endeavour, in consultation with Unions, Clubs, Rugby Bodies, schools and colleges, to set a maximum number of competitive matches that young players should play in any one season as part of a structured season. The number of competitive matches should be determined, in part, by a player's age.
  15. Provide for a maximum ratio of players to coaches which preferably shall be 30:1.
  16. Carry out an annual review of the progress of Licensed Training Centre players and regularly report on each player's progress and activities to that player and his parents or legal guardians.
  17. Take such steps as are necessary to ensure that all players adhere to the World Rugby Code of Conduct and receive appropriate guidance on drug education.
  18. Ensure that in all matches within Licensed Training Centres and/or any training activities, coaches and other Licensed Training Centre personnel arrange a reasonably even matching of opponents.
  19. Ensure that the Laws of the Game (including any variation of the Laws issued by World Rugby or Unions for young players in particular age

categories) are followed, and particular emphasis is given to those Laws that are necessary for player safety.

20. Ensure that young players displaying injury are never encouraged to continue playing.
21. Take steps to ensure that violent actions are discouraged at all times (where appropriate, players must be advised that their on-field activities can lead to prosecution and/or civil action off the field).
22. Ensure that equipment is not only issued and used correctly, but also checked frequently for deterioration that may lead to unsafe situations.

#### **E. Movement of Young Players**

When establishing and/or reviewing their policies for youth development and formulating the conditions pursuant to which a Union operates, or sanctions a Rugby Body or Club to operate a Licensed Training Centre, Unions must be aware that, for compensation to be claimed for a player's training and development if a young player moves from one Union to another, that player must be registered as an Associate Player in a Licensed Training Centre and it will be necessary for the claimant to have complied with (and demonstrate compliance with) these Guidelines.

If Unions elect not to operate Licensed Training Centres and the Associate Player registration scheme or do not allow their Rugby Bodies or Clubs to do so (or if Licensed Training Centres do not meet appropriate standards) Unions, Rugby Bodies or Clubs will not be entitled under these Guidelines to claim compensation in respect of a player's training and development.

## SECTION 2. YOUNG PLAYERS PROTOCOL

### A. Introduction

1. World Rugby for and on behalf of its members recognises the importance of the development of the Game of Rugby Union in all Unions throughout the world.
2. Unions, Rugby Bodies and Clubs must promote the playing of the Game and be encouraged to identify, train and develop young players in order to broaden participation and improve standards in emerging Unions as well as the more developed Unions.

### B. Associate Players

3. The rationale behind the Associate Player Scheme set out in this Protocol, is to reward and protect Unions, Rugby Bodies or Clubs who invest time and resources in developing young players in Licensed Training Centres.
4. In accordance with Section 1 of the Guidelines, Unions may operate or allow Rugby Bodies or Clubs within their jurisdiction, to operate Licensed Training Centres. If a Union, Rugby Body or Club operates a Licensed Training Centre then the Union within which that Licensed Training Centre is established may allow the Licensed Training Centre to register players as Associate Players, provided such players receive regular and frequent coaching and training services through that Licensed Training Centre.
5. Subject to the regulations of the Union in which the Licensed Training Centre is situated, the Licensed Training Centre (for and on behalf of the Union, Rugby Body or Club who is Licensed to run the Licensed Training Centre) shall hold the Associate Player's registration. By retaining an Associate Player's registration, Unions, Rugby Bodies or Clubs who operate Licensed Training Centres will be able to preserve a right to claim compensation in respect of the financial investment made in that player's training and development.
6. Compensation for the investment made in Associate Players may be payable whether the player is transferred before acquiring the status of a Contract Player or if his registration should be transferred while he is still an Associate Player. Any compensation payable in such circumstances should reflect, and be based on the factors set out in paragraph 13 of Section 3 of these Guidelines, in particular, the actual investment made by a Union, Rugby Body or Club in a player registered with a Licensed Training Centre. This will include the quality, regularity/frequency of training and coaching received.
7. The Licensed Training Centre registration scheme for Associate Players is designed to provide an incentive to improve the training and development of young players. Unions, Rugby Bodies or Clubs who operate Licensed Training Centres will know that they are likely to receive an equitable reward for their youth development activities either in the form of that player's services or, should the player move whilst registered as an

Associate Player in a Licensed Training Centre, compensation for the training and development of that player.

**C. Prohibitions**

8. Equally important to encouraging the development of young players throughout the world, raising standards and broadening the Game's playing base in all Unions, is the agreement of all Unions, their members and their constituents to accept and apply this Protocol.
9. An essential component of the Protocol is the prohibition on the unauthorized approach to and/or "poaching" of young players either within a Union and/or between Unions.
10. Unions (and/or their members) who make unauthorised approaches to young players and/or poach or attempt to poach young players shall be subject to sanction.
11. This Protocol requires Unions to impose appropriate sanctions on their members who make any unauthorised approaches to young players and/or poach or attempt to poach young players either within a Union or between Unions. Unions who fail to impose sanctions on members or constituents who fail to adhere to the Protocol and the spirit of the Protocol render themselves liable to sanctions.
12. In order to take advantage of the Associate Player scheme it is necessary for Unions, Rugby Bodies or Clubs, as the case may be, to invest in effective training and development programmes. World Rugby believes that Licensed Training Centres and the Associate Player compensatory scheme provides the appropriate mechanism to protect the interests of Unions, Rugby Bodies, Clubs and players. It will allow the monitoring of a player's progress and the protection of his broader educational interests whilst providing an appropriate degree of control over youth development to be exercised at Union level.

**D. The Training and Development Bargain**

13. Unions must ensure that Licensed Training Centres are properly structured and offer players a meaningful opportunity to develop their skills. Unions must impose and enforce licensing conditions on Licensed Training Centres that require the highest ethical and playing standards to be applied and the Fundamental Requirements set out in Section 1 maintained.
14. If the benefits to a player (for example, in terms of regular/frequent good quality coaching and training activities) cannot be demonstrated, then there is a risk that provisions designed to protect the investment made by Unions, Rugby Bodies or Clubs in that young player's training and development will be by-passed or deemed unenforceable. It is necessary, therefore, to demonstrate that there is, in effect, a discernible "bargain" between the Associate Player and the Union, Rugby Body or Club operating the Licensed Training Centre in question.

15. The Union, Rugby Body or Club provides “consideration” through the Licensed Training Centres in the form of regular/frequent training, coaching, practice matches, provision of medical care and related matters (all of which protect the Player’s health and welfare whilst maximising an Associate Player’s potential to take up the Game professionally). The Associate player commits himself “contractually” to the Licensed Training Centre via his registration as an Associate Player.
16. When dealing with minors it is necessary to ensure that all arrangements, in particular, contractual/registration arrangements which, through a Licensed Training Centre, tie an Associate Player to a Union, Rugby Body or Club, are framed and seen to work for the player’s benefit. If not, such arrangements may be voidable and are unlikely to be accepted by the players, parents (legal guardians), schools or colleges.
17. World Rugby considers that Licensed Training Centres, properly regulated by Unions, that apply high standards of coaching and training and provide other benefits to young players, including educational support, will attract a growing number of new participants and, by rewarding investment in training and coaching of young players, encourage greater youth development activity.
18. World Rugby shall, with the assistance Unions, monitor the operation of Licensed Training Centres and the Associate Player scheme to assess its effectiveness in meeting World Rugby objectives. World Rugby may issue further Guidelines or vary, revoke or supplement the above from time to time.

### SECTION 3. COMPENSATION FOR THE TRAINING AND DEVELOPMENT OF YOUNG PLAYERS

1. The Guidelines set out below have been developed to encourage Unions, Rugby Bodies and Clubs to invest in the development of young players and To help ensure that Unions, Rugby Bodies and Clubs, as the case may be, are properly compensated for their investment in the future of the game.
2. As part of their general youth development activities Unions should develop centrally administered licensing schemes for Training Centres. Such licensing schemes must, as a minimum requirement, ensure that there is compliance with the Fundamental Requirements set out in Section 1 of the Guidelines. For young players who receive regular/frequent coaching and training services in a Licensed Training Centre, Unions should establish an “Associate Player” scheme. Licensed Training Centres should be allowed, through their Union’s central registration programme, to register young players who are receiving regular training and/or coaching services in Licensed Training Centres as Associate Players.
3. Under an Associate Player scheme, players over the age of 16, but under the age of majority, who are receiving regular/frequent training and/or coaching services in a Licensed Training Centre, may be registered in that Licensed Training Centre as an Associate Player.
4. Unions should develop a standard Associate Player Registration Form for use by Licensed Training Centres within their jurisdiction. This form must be signed by the player, the players’ parent(s) (or person with parental responsibility) and the player’s head teacher or equivalent person with overall responsibility for the player’s education. All the parties must agree before a player acquires the status of an Associate Player. The form must set out, as clearly as possible, the relevant regulations, governing Associate Players and the obligations on both the player and the Licensed Training Centre.
5. Each Union should prescribe a maximum number of Associate Players that a Licensed Training Centre may register, the recommended number being 30 (although this number may be exceeded at the discretion of a Union where, for example, a Union has only one Licensed Training Centre within its Jurisdiction.)
6. If a player signs and is registered as an Associate Player with a Licensed Training Centre he shall not be entitled to become an Associate Player with another Licensed Training Centre (and/or be registered to play or train with a Union, Rugby Body or Club in any other capacity), unless the Licensed Training Centre to which he is currently registered agrees in writing.
7. Associate Players’ registrations will only be valid for one calendar year from the date the Associate Player Registration Form was signed and the player was registered, unless the Licensed Training Centre elects to retain

the Associate Player's registration for a further calendar year or, in the case of a player who has reached the age of majority (or will do so within 6 months), the Associate Player has been offered a contract by the Union, Rugby Body or Club operating the Licensed Training Centre, pursuant to which he will receive Material Benefit.

8. Subject to paragraph 7 above, an Associate Player's registration will expire one calendar year from the date he signed the Associate Player Registration Form and was registered as an Associate Player. After this calendar year has expired the player may join another Licensed Training Centre as an Associate Player or be registered with a Union, Rugby Body or Club in another capacity.
9. An Associate Player who is registered with a Licensed Training Centre shall be entitled, at any time, to apply to the Licensed Training Centre for cancellation of his registration as an Associate Player. In the event of such an application, an Associate Player cannot be registered with a Licensed Training Centre (and may not be registered with or play or train for a Union Rugby Body or Club for a period of 6 months from the date of the application), except with the consent of the Licensed Training Centre with which he was registered as an Associate Player, and/or on payment of compensation to that Licensed Training Centre by the Licensed Training Centre, Union, Rugby Body or Club for whom the player wishes to register. If an Associate Player believes that the Licensed Training Centre that he is registered with is in breach of its obligations and/or failing to provide appropriate training and development activities, the Associate Player may apply to the Union that licenses the Centre in question and request that his registration be cancelled. The Union should undertake an investigation into such application and, where appropriate, refer the matter to its relevant body for adjudication.
10. If an Associate Player's registration is transferred from one Licensed Training Centre to another, or the player is registered with a Union, Rugby Body or Club in another capacity, the Union, Rugby Body or Club responsible for funding/operating the Licensed Training Centre, at which the player received regular training and coaching services and was registered as an Associate Player, is entitled to make a claim for compensation for the training and development of the Associate Player. When the Union, Rugby Body or Club responsible for the operation of a Licensed Training Centre believes that it is entitled to compensation then the Union, Rugby Body or Club, as the case may be, must complete a standard form setting out the basis of the claim and submit it to the relevant Union, Rugby Body or Club. It should then seek to agree the amount of compensation as soon as possible.
11. Associate Players approaching or attaining majority may, where appropriate, be offered a contract pursuant to which he will receive Material Benefit, and sign as Contract Players, with the Union, Rugby Body or Club operating the Licensed Training Centre. Such offers may only be made within the 6 months before the player acquires the age of majority. If the Associate Player rejects the offer to become a Contract



Player with the Union, Rugby Body or Club (as the case may be) that operated the Licensed Training Centre that he is registered with as an Associate Player (and in which he received his training/coaching services) then, if that player elects to move to another Union, Rugby Body or Club as a Contract Player within 12 months from the date of the offer made through the Licensed Training Centre with which he is registered as an Associate Player the Union, Rugby Body or Club that funded/operated the Licensed Training Centre shall be entitled to claim compensation for that Associate Player's training and development.

12. The amount of compensation, if any, payable pursuant to paragraphs 9, 10 or 11 above shall be agreed between the relevant parties. If no agreement can be reached between the relevant parties within 28 days from the request for compensation, the relevant Union, Rugby Body or Club having jurisdiction over and/or responsible for the funding of the Licensed Training Centre(s) should refer the matter to the body designated by the Union or World Rugby (as the case may be) who shall set the appropriate level of compensation, if any, for that player's training and development.
13. If a dispute over the payment of compensation for the registration of an Associate Player arises and such dispute is between Licensed Training Centres or Rugby Bodies or Clubs within the Jurisdiction of one Union, then the dispute should be dealt with by that Union having Jurisdiction over those Licensed Training Centre(s), Rugby Bodies or Clubs. If the dispute concerns Licensed Training Centres or Rugby Bodies or Clubs in different Unions then the matter shall be adjudicated on by the CEO or his designee(s). The CEO or his designee(s) shall be entitled to regulate its own procedures provided the parties are allowed to make representations and have a reasonable opportunity to present their case. For the avoidance of any doubt, any dispute over the payment of compensation for the training and development of an Associate Player shall not prevent that player from moving, subject to paragraph 9 above, and/or where that player is in breach of the Associate Player regulations.
14. In determining the amount of compensation, if any, in respect of an Associate Player's training and development the following factors shall be taken into account:
  - (a) Actual training costs in relation to the player incurred by the relevant Union, Rugby Body or Club operating the Licensed Training Centre during the period of the player's registration with the Licensed Training Centre. Training costs shall include, but not be limited to:
    - (i) proportionate salary or compensation paid to coaches;
    - (ii) board and lodging;
    - (iii) proportionate costs of training infrastructure (for example, hire of facilities, equipment);
  - (b) Medical costs expended on the player;

- (c) Non-rugby related expenditure in respect of a player provided by the Licensed Training Centre (for example, schooling and academic expenses);
  - (d) Other general costs that can be attributed, either in full or in part, to the player's rugby education, training and development.
  - (e) National Representative Team appearances of the player (at all age levels);
  - (f) Age of the player; and
  - (g) Length of time the player trained in the Licensed Training Centre.
15. In the event that a Licensed Training Centre(s) and/or Union, Rugby Body or Club (as the case may be) are dissatisfied with the ruling on compensation when an Associate Player moves from one Union to another Union, then that body may appeal provided such appeal is received by the CEO within 14 days of the decision of the original decision by the CEO or his designee being communicated to the parties. The CEO may refer the appeal to an adjudicatory body made up of Appeal Panel Members who shall be responsible for regulating the procedure adopted on such an appeal, provided that the relevant parties are given a reasonable opportunity to make representations and present their case. The decision of that adjudicatory body shall be final and binding on the parties.

---

## EXPLANATORY NOTE. REGULATIONS GOVERNING PLAYER STATUS AND PLAYER MOVEMENT

### Introduction

World Rugby is committed to attracting new Players to the Game and raising playing standards at all levels and in all member Unions. It is of fundamental importance to the future growth and development of the Game that all Member Unions, Rugby Bodies and Clubs are enabled and encouraged to attract new generations of Players to the Game within their own jurisdiction. In order to promote this development, encourage both mature and emerging Unions to identify, train and develop Rugby Players, World Rugby has agreed Regulations governing international Player movement. Regulation 4 is intended to:

- (a) Encourage Unions, Rugby Bodies and Clubs at all levels to identify and develop young Players;
- (b) Broaden the Game's playing base in all Unions;
- (c) Ensure appropriate compensation in the event of players developed within one Union moving to play in another Union;
- (d) Promote stability and facilitate the monitoring of international Player movement;
- (e) Create an effective mechanism to redistribute resources throughout the Game;
- (f) Identify the principles which Unions are encouraged to follow when introducing and/or developing their domestic intra-Union player movement, training and development compensation schemes.

### Ambit of this Explanatory Note

Regulation 4 incorporates a compensation scheme that provides in certain circumstances for the payment of compensation to reflect the investment in the training and development of Rugby Players.

### International

This Explanatory Note (and the forms appended to it) have been prepared for use by Unions (and their members) to explain the mechanics of Regulation 4, in particular the compensation scheme, and to assist in the introduction and the ongoing implementation of Regulation 4.

### Domestic

Regulation 4 relates, principally, to the movement of Players between Unions; however, for that to be fully effective an appropriate domestic set of rules is also required. Thus Regulation 4.3 requires:

- (a) Each Union to provide appropriate regulations for the movement of players within their jurisdiction. Unions are responsible for ensuring that their members are properly informed about the way in which Regulation 4 operates and are responsible for introducing internal player movement regulations based on the principles within Regulation 4 that properly reward their constituents for their player identification, training and development activities.
- (b) Each Union to register, thereafter, its regulations with World Rugby. World Rugby considers that the principles enshrined in the compensation system within Regulation 4 are appropriate to achieve the vital objectives of encouraging and providing compensation for the identification, training and development of young players, and that as such they represent best practice. Accordingly, the regulations of Unions for the movement of players are expected, as far as reasonably practical, to incorporate the principles of compensation set out in Regulation 4. World Rugby may monitor the player movement regulations of Unions to verify that the regulations proposed by Unions are appropriate and that the compensation mechanism substantially complies with the principles of Regulation 4. It is essential that all Unions in membership of World Rugby recognise the important role that they have to play in the effective implementation of Regulation 4. This Explanatory Note should not be read in isolation. The Explanatory Note is not a substitute for the Regulation and must be read in conjunction with Regulation 4.

## **1. Determining a Player's Status**

- 1.1 The status of a Player is a key factor in determining whether any compensation for his training and development is payable.
- 1.2 Under Regulation 4 there are two categories of Player Contract and Non-Contract Players. A Player is a Contract Player if he is currently receiving, or has previously received Material Benefit. All other Players are Non-Contract Players.<sup>8</sup>
- 1.3 A Contract Player must have or have had a written agreement with his Club, Union or other Rugby Body that pays him Material Benefits.

---

<sup>8</sup> *Players may not enter into written agreements until they have reached the age of contractual majority within the relevant jurisdiction. However, there is an exception for Players over 16 if the Material Benefit received by the Player under the written agreement takes the form of a non-refundable financial grant to be applied only for the purposes of the Player's academic and/or vocational training for a period of twelve months or longer. Each Union should establish its own regulations relating to the registration and development of young Players. Such regulations should provide that the relevant body responsible for the training and development of the player has the first option on a Player's professional services when he acquires the age of majority. World Rugby may issue guidelines to assist this process.*

1.4 Each Union must develop standard form written agreements for use by itself or its Clubs and Rugby Bodies, (as appropriate) and Players within their jurisdiction.<sup>9</sup>

1.5 Each Club or Rugby Body must submit copies of all written agreements with Players to its Union.

## **2. Obtaining a Clearance**

2.1 Under Regulation 4 a Clearance system will continue to be operated by World Rugby. Any Player leaving his Current Union will not be eligible to participate in competitions organised, recognised or sanctioned by a New Union unless he has received a Clearance to do so.

2.2 Clearances will only be accepted in the standard form set out in Appendix 1 and signed by the appropriate parties.

2.3 Where the Contract Player has not been registered with his current Union for a period of 12 months or more, then the current Union shall specify on the Clearance the period of rest the Contract Player has obtained during the period for which the Contract Player was with the current Union. "Rest" for the purposes of the Clearance shall mean the period during which the Contract Player did not participate in any Match(es) and shall not include injury periods.

2.4 A Clearance is not provisional in nature. It remains valid pursuant to Regulation 4 until it is replaced by a subsequent Clearance.

## **3. The Significance of Existing Written Agreements**

3.1 Regulation 4 distinguishes between the movement of Players during the course of a written agreement, and the movement of Players who are either Non-Contract Players or Contract Players whose written agreement has expired.

3.2 A Contract Player may only move to another Union, Rugby Body or Club during the period of a written agreement if his existing Union, Rugby Body or Club, the Union, Rugby Body or Club he is proposing to join and the Player concur.

## **4. The principles of Compensation for Training and Development**

4.1 In recognition of the investment made by Unions, Rugby Bodies and Clubs (as the case may be) in the training and development of Rugby Players, Regulation 4 provides that, in certain circumstances, compensation for the investment in a Player's training and development may be payable in respect of Non-Contract Players or Contract Players whose written agreement has expired.

---

<sup>9</sup> *Standardisation of Player written agreements serves a number of different purposes. The Union's and World Rugby's Regulations are expressly accepted by all Players, Rugby Bodies and Clubs. In addition, Unions can maintain a centralised register of Contract Players in order to monitor Player movement and identify the status of a Player at any given time, thereby easing the administration of Regulation 4. It will also assist Unions to apply internal compensation systems incorporating the principles and policies set out in Regulation 4.*

- 4.2 The trigger for a compensation claim is the movement of a Player for the first time outside of his Home Union (i.e. the Union with which the Player is, or was first Registered or, if different, the Union where a Player was trained or developed).
- 4.3 Under Regulation 4 compensation is only payable when a Player moves outside of his Home Union for the first time and enters into a written agreement, either immediately or within 3 years, to play rugby in another Union.
- 4.4 Compensation is based on the Standard Annual Development Investment representing the investment that a Union, Rugby Body or Club can demonstrate has been made in a Player's training and development and the other factors set out in Regulation 4.7.5.
- 4.5 In effect, a Union, Rugby Body or Club should be properly reimbursed for its "research and development" efforts in respect of Players. It is essential, therefore, that appropriate records of a Player's progress are maintained.
- 4.6 The quality of training and development invested in a Player will not only improve that Player's prospects of playing the Game full time it will also raise playing standards in general.
- 4.7 The compensation scheme should provide an incentive for all Unions, Rugby Bodies and Clubs to increase and improve their training and development programmes with appropriate support from their Unions and World Rugby.<sup>10</sup>

## **5. When can Compensation be Claimed?**

- 5.1 The Union, and/or Rugby Body and/or Club who trained and developed a Player is entitled to claim compensation on the transfer of a Player's registration in the following circumstances only:
- 5.1.1 when a Contract Player, whose written agreement has expired, enters into a written agreement for the first time with a Union, Rugby Body or Club outside his Home Union (Regulation 4.7.2(a));
- 5.1.2 when a Non-contract Player enters into a written agreement for the first time with a Union, Rugby Body or Club outside his Home Union (Regulation 4.7.2(b));

---

<sup>10</sup>The general principles of international Player movement are illustrated diagrammatically in Appendix 2.

5.1.3 if a Contract Player does not enter into a written agreement immediately, but enters into a written agreement outside his Home Union within 3 years of the date on which he competed in his last match as a Contract Player in his Home Union (Regulation 4.8.2);

5.1.4 if a Non-Contract Player does not enter a written agreement immediately, but enters into a written agreement for the first time with a Union, Rugby Body or Club outside his Home Union, within 3 years of the date on which he moved outside his Home Union, (Regulation 4.8.3).

## 6. How should Compensation be Claimed?

6.1 When a Union, Rugby Body or Club believes that it is entitled to compensation under Regulation 4 then the Union, Rugby Body or Club (as the case may be) must:

6.1.1 Complete the World Rugby Player Movement Compensation Claim Form in full (see Appendix 3). The form must be certified.

6.1.2 Send the fully completed and certified form, to the Union, Rugby Body or Club to whom the Player proposes to move.

6.1.3 Seek to agree the amount of compensation payable as soon as possible.

6.2 If the amount of compensation, if any, cannot be agreed between the relevant parties within 28 days of Clearance having been given to a Player, one of the Unions involved may refer the matter to World Rugby. (If the dispute involves a Rugby Body or Club then the Rugby Body or Club (as the case may be) should refer the matter to their Union and ask that the Union refer the matter to World Rugby.)<sup>11</sup>

6.3 An independent expert(s) shall consider the case promptly and determine the amount of compensation payable, if any. The independent expert(s) will regulate the procedure on such a referral and may elect to deal with the case on the basis of written representations alone. NB. The original World Rugby Player Movement Compensation Claim Form, (see 8(a)(i) above) must, be submitted in evidence to the independent expert(s) in all cases.

## 7. How is Compensation Calculated?

7.1 Compensation is calculated using the formula in Regulation 4.7.4.

7.2 The actual amounts payable at the conclusion of each development year, pursuant to the calculation of Figure 1 in Regulation 4.7.4, are shown in the Figure 2 below: Compensation payable (£) at age of transfer relative to the number of years involved in High Performance development programmes.

---

<sup>11</sup>Unions should provide appropriate bodies to adjudicate on disputes between their own constituents over compensation payable when a player moves within that Union. Preferably, those making the decisions should be players with experience in player development issues.

		Years in Development Programme						
		1	2	3	4	5	6	7
Age at transfer	17	5,000	-	-	-	-	-	-
	18	5,000	10,000	-	-	-	-	-
	19	5,000	10,000	15,000	-	-	-	-
	20	5,000	10,000	15,000	20,000	-	-	-
	21	5,000	10,000	15,000	20,000	25,000	-	-
	22	5,000	10,000	15,000	20,000	25,000	30,000	-
	23	5,000	10,000	15,000	20,000	25,000	30,000	35,000
	24	-	-	-	-	-	-	-
	25	-	-	-	-	-	-	-
	26	-	-	-	-	-	-	-
	27	-	-	-	-	-	-	-
	28	-	-	-	-	-	-	-
	29	-	-	-	-	-	-	-
	30	-	-	-	-	-	-	-
21	-	-	-	-	-	-	-	

Where a Player transfers during a development year, the amount of compensation payable will be pro-rated by month.

Illustration 1:

Joe Smith transfers from Union A to Union B at the age of 22, having been in Union A's High Performance development program since he was 17 (five years). Union B must pay development compensation to Union A of £25,000:

$$\begin{aligned} \text{Compensation} &= \text{£}5,000 \times 5 \text{ years} \\ &= \text{£}25,000 \end{aligned}$$

Illustration 2:

If the Player in Illustration 1 stayed with Union A, before transferring from Union A to Union B at the age of 27, then no compensation would be payable to compensate for his development. This is because his age at transfer is over 23.

Illustration 3:

John Jones enters Union C's High Performance development program aged 19 and transfers to Union D after just one year, aged 20. Union D must pay development compensation to Union C of £5,000:

$$\begin{aligned} \text{Compensation} &= \text{£}5,000 \times 1 \text{ year} \\ &= \text{£}5,000 \end{aligned}$$



## Illustration 4:

If the player in illustration 3 stayed in Union C's development program, before transferring to Union D midway through his fourth year, the compensation payable would instead be:

$$\begin{aligned}\text{Compensation} &= \text{£}5,000 \times 3 \text{ \& } 6/12 \text{ years} \\ &= \text{£}17,500\end{aligned}$$

## Illustration 5:

Paul Williams enters Union E's High Performance development program aged 18 and completes two full years. He then withdraws from the program for personal reasons, three-quarters of the way into his third year and subsequently misses the fourth year. He re-enters the program in his fifth year, before transferring to Union F after six months, aged 22. The compensation payable from Union F to Union E is:

$$\begin{aligned}\text{Compensation} &= \text{£}5,000 \times [(2 \text{ \& } 9/12)+(0 \text{ \& } 6/12)] \\ &= \text{£}5,000 \times 3.25 \\ &= \text{£}16,250\end{aligned}$$

## Illustration 6:

If the Player in illustration 5 did not re-enter the development program, and was thus a non-contract Player at the time of transfer, the compensation payable from Union F to Union E would be:

$$\begin{aligned}\text{Compensation} &= \text{£}5,000 \times 2.75 \\ &= \text{£}13,750\end{aligned}$$

**8. Payment**

Once compensation has been agreed between the relevant parties, monies shall be paid by the Player's New Union, Rugby Body or Club to the Player's Home Union. Each Union shall be entitled to distribute such monies to Rugby Bodies and Clubs in its membership as it sees fit.<sup>12</sup>

**9. Enforcement**

When a Rugby Body or Club is required to pay compensation for a Player's training and development (or is ordered to do so) the Union to which the Rugby Body or Club is affiliated, in the event of default by the Rugby Body or Club is liable for the payment of the compensation as principal debtor.

---

<sup>12</sup>This centralised system is designed to allow Unions to determine how funds should be allocated out of any compensation payment. It recognises the different structure of Rugby in different Unions and allow Unions to agree appropriate arrangements with their constituent members bodies.

---

**APPENDIX 1. CLEARANCE**

1. Name of Player: ..... (*"Player"*)  
(*Surname*) (Forenames)  
Address of the Player: .....  
.....  
.....
2. Name of Union, Rugby Body or Club with which the Player is Registered currently:  
.....
3. Name of Union with which Player is affiliated:  
..... (*"Current Union"*)
4. Name of Union for which the Player is eligible to play in International Matches:  
.....
5. Highest level at which the Player has played whilst Registered in Current Union (*e.g. International/Representative (state level), Club or other Rugby playing organisation (state level)*):  
.....
6. Union within which the Player proposes to Register and play:  
..... (*"New Union"*)
7. If the Player is a Contract Player, the date on which his written agreement within his Current Union came/will come to an end (A copy of the Player's current/most recent contract must be attached to this Clearance).  
.....
8. In the preceding 12 months the Contract Player has obtained the following period of rest:  
[ ] weeks and [ ] days – rest from any Match(es) and/or team training  
[ ] weeks and [ ] days – rest from any Match participation (excluding periods of injury)
9. The date of the Contract Player's last Match was:  
.....  
(*Date*) (Teams)

## DECLARATION OF CURRENT UNION

1. The information set out above is true and correct in every respect.
2. The Player is not currently under suspension on disciplinary grounds (which, for the avoidance of doubt, shall include any Doping Offence) for a period of more than five weeks. The New Union has agreed that any current suspension of the Player shall apply to matches played under its jurisdiction.
3. If the Player is a Contract Player, the Player has no outstanding obligations under the terms of his written agreement with his Union, Rugby Body or Club.

Signed by:

.....  
(Signature)

.....  
(Print Name)

An authorised signatory on behalf of:

..... Dated: .....

.....  
(Name of Current Union)

Acknowledged and agreed by:

.....  
(Signature)

.....  
(Print Name)

An authorised signatory on behalf of:

..... Dated: .....

.....  
(Name of Current Union)

Acknowledged and agreed by:

.....  
(Signature)

.....  
(Print Name)

An authorised signatory on behalf of:

..... Dated: .....

.....  
(Name of Union for whom the Player is eligible to play in International Matches  
(if different from Current or New Union)).

1. Regardless of the signature and dating of this Clearance, this Clearance shall only become effective when:
  - (i) the New Union has received an original version (or a facsimile copy of the original version) of the Clearance;
  - (ii) the Player's written agreement with his Current Union has expired or been terminated; and
  - (iii) the Player's Registration within his Current Union has been cancelled.

Capitalised terms used in this Clearance shall have the meaning given to them in the World Rugby Regulations Relating to the Game (as amended from time to time).

---

**APPENDIX 2. THE PRINCIPLES OF INTERNATIONAL  
PLAYER MOVEMENT****1. Regulation 4.7.1 - Contract Player moves during contract.**

Existing Contract

New Contract

All 3 parties must agree to the move

New Club/Union and Current Club/Union to agree compensation (if any)

**2. Regulation 4.7.2(a) - Out-of-contract Player enters into written  
agreement outside his Home Union for first time.**

Once-only compensation fee payable by New Contract Club/Union to Home Union for Player's training and development ("Home Union" means the Union with which a Player is first registered or, if different, the Union where he was trained and developed)

Contract Player Current

Club/Union

New Club/Union

Contract Player Home Union

New Club/Union

**3. Regulation 4.7.2 (b) - Non-Contract Player enters into written  
agreement with Club/Union outside of his Home Union for first time.**

New Contract Once-only compensation fee payable by New Club/Union to Home Union for Player's training and development

**4. Regulation 4.7.2 (c) - Non-Contract Player moves to another Union  
and retains his status as a Non-Contract Player.**

No Contracts

No compensation payable

Amateur Player

New Club/Union

Current Club/Union

Home Union Non-Contract Player

New Club/Union

---

**APPENDIX 3. INTERNATIONAL PLAYER MOVEMENT  
COMPENSATION CLAIM FORM**

**1. Player details:**

Surname: ..... Forename(s): .....

Address: .....

.....

..... Tel: .....

Age: ..... Date of Birth: .....

Current Union: ..... Home Union: .....

**2. Player's Union/Rugby Body/Club [please delete] completing this form ("the Claimant"):**

Name: .....

Address: .....

.....

..... Tel: .....

Union: .....

**3. Player Status:**

(a) Is the Player registered with his current Union? Yes No

(b) Is the Player a registered Contract Player? Yes No

(c) Is the Player a registered Non-Contract Player? Yes No

Date of registration with Union: .....

Date of registration as a Contract Player: .....

**4. Has the Player entered into a written agreement with a Union, Rugby Body or Club OUTSIDE HIS HOME UNION before?**

Yes No

**5. State the amount of compensation claimed by the Claimant for the Player's training and/or development:**

Amount: .....

**6. In respect of your claim for compensation for this Player please provide a history of the Players career to date including the following information:**

(a) Proportion of salary(ies) or compensation paid to Coach(es):

.....  
.....

(b) Board and lodging:

.....  
.....

(c) Proportion of travel costs to away matches:

.....  
.....

(d) Proportion of cost of training and development infrastructure (eg. hire / construction of facilities/equipment):

.....  
.....

(e) Medical costs expended on the Player:

.....  
.....

(f) Non-rugby related expenditure in respect of the Player provided by the Union, Rugby Body or Club, as the case may be, (for example schooling and academic expenses):

.....  
.....

(g) Other general costs that can be attributed, either in full or in part, to the player's rugby education, training and development.<sup>13</sup>

.....  
.....

Please continue on a separate sheet if necessary.

---

<sup>13</sup>Do not include expenses attributable to playing, training and development activities that formed part of the Player's general academic education.

**7. Please provide the following information:**

(a) Playing experience of the Player (e.g. National representative appearances of the Player at all age levels; senior appearances with the Claimant):

.....  
.....

(b) Length of time the Player trained with the Claimant:

.....  
.....

Other (please state):

.....  
.....  
.....  
.....

Please continue on a separate sheet if necessary.

**Declaration:**

I am authorised on behalf of the Claimant to certify that the information contained in this form is correct.

I do so in the knowledge that the Claimant may be called upon by World Rugby to further justify and verify the information contained in this form and that any incorrect or misleading information will render the Claimant liable to sanction by World Rugby and/or the Claimant's Union.

Signed:

.....  
(Signature) (Print Name)

Official capacity:

..... Date: .....



### REGULATION 5. AGENTS

- 5.1** Each Union is responsible for the authorisation and regulation of Agents acting on behalf of its members (or Persons within its jurisdiction) and Agents operating under that Union's jurisdiction. Each Union shall establish appropriate regulations to govern and authorise the activity of Agents. Such regulations shall be registered with World Rugby. In any event, all regulations established by a Union in respect of Agents, must contain the general principles set out in Regulation 5.1.1 to 5.1.10 below:
- 5.1.1** An Agent shall abide, in all respects, by these Regulations and the Bye-Laws and the regulations of other relevant national Unions;
- 5.1.2** An Agent shall not act for more than one party in any transaction and shall disclose in writing to his principal any formal or informal relationship which the Agent has, or has had, with any other party to a transaction;
- 5.1.3** In all discussions, negotiations and transactions relating to any Person, an Agent shall act in good faith and disclose in writing the identity of the Person, Union, Rugby Body or Club for whom the Agent is acting;
- 5.1.4** An Agent shall not take any steps to induce, or any steps which are intended to induce, any Person to act in breach of his written agreement with any Union, Rugby Body or Club;
- 5.1.5** Agents shall conduct themselves at all times in an ethical manner and shall observe the highest standards of integrity and fair dealing;
- 5.1.6** Agents should have in place appropriate professional liability insurance with a reputable insurer to an appropriate level;
- 5.1.7** Agents approved by Unions to act, and/or licensed by Unions may not transfer such approval and/or licence which should be deemed to be strictly personal to the individual Agent concerned;
- 5.1.8** Unions shall be entitled to take disciplinary action against Agents and impose, in appropriate cases, disciplinary sanctions including the ability to prevent an Agent from acting within its jurisdiction;
- 5.1.9** Agents should comply with best accounting practice and make available books and records to relevant authorities, as appropriate, for audits or other relevant purposes;
- 5.1.10** Each Union shall procure jurisdiction for World Rugby to adjudicate on cases arising out of international transactions and/or a breach of Agent Regulation which is of an international nature, and to take such action and impose and enforce such penalties, as are appropriate in relation to the Agent, Club and/or Rugby Body concerned, such penalties and/or action to include, but not be limited to:

- (i) A reprimand, censure, caution;
- (ii) A fine;
- (iii) A suspension of the entitlement to act as an Agent;
- (iv) Withdrawal of entitlement as an Agent;
- (v) Such other sanction as may be appropriate in the particular circumstances.

**5.2** Each Union should, as far as it is reasonably practicable, require that all contracts between Players and Agents, and any variation thereof, shall be in writing, shall not be capable of remaining in force for a period exceeding two years, shall only be assignable or transferable with the player's written consent and shall clearly state the basis upon which the Agent is to be remunerated. The basis on which any such remuneration is to be calculated must be reasonable. An Agent shall only accept fees or other remuneration from the person or principal by whom he is engaged.

## REGULATION 6. ANTI-CORRUPTION AND BETTING

### 6.1 Introduction and Scope

- 6.1.1 World Rugby is committed to making all efforts within its power to preserve the fundamental character of sporting competition as an honest test of skill and ability and to prevent corrupt gambling practices from undermining the integrity of the Game. These Anti-Corruption Regulations establish a set of regulations and a scheme of enforcement and sanctions to apply across the Game at International and Contract Player level and provide guidance to Unions in respect of their domestic regulations.
- 6.1.2 World Rugby recognises that education is a key element to the effective implementation of these Anti-Corruption Regulations. Further, World Rugby, all Unions and Rugby Bodies shall within their means and scope of responsibility and in co-operation with each other, plan, implement, evaluate and monitor information and education programmes for anti-corruption purposes within the Game.
- 6.1.3 World Rugby has adopted these Anti-Corruption Regulations in recognition of the following fundamental imperatives in the Game:
- (a) All Matches shall be contested on a level-playing field, with the outcome and all aspects of each Match to be determined solely by the merits of the competing Players and teams and their respective coaching, medical and other player support personnel.
  - (b) Public confidence in the authenticity and integrity of the sporting contest is of paramount importance. If that confidence were to be undermined the Game would be fundamentally affected.
  - (c) Technology, popularity, television, the number and form of Matches and the expansion of betting markets has led to a significant increase in the amount and different types of Bets being placed on the Game. Gamblers may place legal Bets from remote locations, including within Match venues, via internet, telephone and on-site bookmakers in various jurisdictions, including while a Match is in play. These developments raise the potential for persons not connected with the Game to attempt to corrupt persons within the Game and for persons in the Game to seek to gain from corrupt gambling.
  - (d) Inherently, any persons involved in this type of Misconduct may act across different competitions and will ordinarily go to great lengths to keep their activities secret from World Rugby, Unions, competent authorities and the public. In order to protect the integrity of the Game World Rugby requires the power to obtain information and records from persons involved in the Game at the elite level and to share information with Unions, police and other competent authorities and relevant third parties as appropriate.

- (e) Persons who are or who seek to be involved in the Game shall be of suitable character reflecting the integrity, reputation and spirit of the Game. They shall be responsible for adhering to the letter and spirit of these Anti-Corruption Regulations.
- (f) These Anti-Corruption Regulations shall be interpreted and applied by reference to the fundamental sporting imperatives set out in this Regulation 6.1.3 in preference of any strict legal and/or technical interpretation which may be proposed.

These Anti-Corruption Regulations reflect the Olympic Movement Code on the Prevention of the Manipulation of Competitions as appropriate in the context of the Game.

6.1.4 All Connected Persons are automatically bound by and required to comply with all of the provisions of these Anti-Corruption Regulations. Accordingly, by their involvement in the Game Connected Persons shall be deemed to have agreed:

- (a) That it is their responsibility to read and ensure that they understand all of the provisions of these Anti-Corruption Regulations and to comply therewith. Further, that each of them has a duty to inform all of their associates (which may include family and non-family members) as appropriate of the scope and application of these Anti-Corruption Regulations to them.
- (b) To submit to the authority of World Rugby and their Union to adopt, apply, monitor and enforce these Anti-Corruption Regulations.
- (c) To submit to the exclusive jurisdiction of any Judicial Officer and/or Judicial Committee and/or Appeal Committee appointed to hear and determine charges brought by World Rugby and/or a Union and/or to address other issues pursuant to these Anti-Corruption Regulations.
- (d) Not to bring any proceedings in any court or other forum which are inconsistent with the foregoing submission to the jurisdiction of a Judicial Officer and/or Judicial Committee and/or Appeal Committee appointed in accordance with World Rugby Regulations.

6.1.5 All Connected Persons shall where requested by a Union, Rugby Body or World Rugby (or their authorised representative(s)) for the purposes of applicable data protection and other laws and applicable purposes relating to or in connection with these Anti-Corruption Regulations be obliged to and shall consent in writing to the collection, processing, disclosure and use of information (including without limitation personal information) relating to themselves and their activities.

6.1.6 There shall be no statute of limitations applicable to these Anti-Corruption Regulations. Unions shall use their best endeavours to ensure that All Connected Persons including in particular Contract Players and Contract Player Support Personnel shall continue to be bound by and are required to comply with these Anti-Corruption Regulations for a period of six months following the cessation of their duties in relation to the Game.

6.1.7 Conduct prohibited under these Anti-Corruption Regulations may also be a criminal offence and/or a breach of other applicable laws and/or regulations in certain jurisdictions. These Anti-Corruption Regulations are intended to supplement such laws and regulations as further rules of conduct for those involved in the Game. They are not intended, and should not be interpreted, construed and/or applied, to prejudice and/or undermine in any way the application of such laws and/or regulations. Connected Persons must comply with all applicable laws and regulations at all times. World Rugby acknowledges that cooperation with public authorities by it and Unions and Associations, in particular law enforcement and sports betting entities, is crucial.

## 6.2 Definitions

The definitions set out below apply to these Anti-Corruption Regulations. In the event of any inconsistency between these definitions and those set out in Regulation 1, then these definitions shall prevail for the purposes of this Regulation.

**Anti-Corruption Breach** Any breach of these Anti-Corruption Regulations. For the avoidance of doubt an Anti-Corruption Breach shall also constitute Misconduct.

**Anti-Corruption Officer** The person, or his nominee, appointed from time to time as Anti-Corruption Officer of World Rugby.

**Attempt** An act(s) and/or omission(s) which is more than mere preparation and which constitutes a real and substantial step(s) (individually or cumulatively) towards the commission of an Anti-Corruption Breach (in circumstances where, save for the Attempt itself, the Anti-Corruption Breach was not committed and/or completed and notwithstanding whether the person(s) involved was aware that the act(s) and/or omission(s) may amount to an Anti-Corruption Breach). Where an Attempt is renounced by the perpetrator by way of making a report to the Anti-Corruption Officer prior to such Attempt being discovered by a third party this may be taken into account by the Judicial Officer, Judicial Committee and/or Appeal Committee to reduce the sanction which may otherwise have been applicable. Renunciation and/or withdrawal shall not be relevant save where the foregoing conditions are met nor shall prevention and/or impossibility and/or ineptitude be relevant in relation to an Attempt.

**Benefit** Any direct and/or indirect monetary and/or non-monetary bribe(s), gain(s), benefit(s), gift(s) and/or advantage(s), including, without limitation, winnings and/or potential winnings as a result of a Bet(s). The foregoing shall not include official prize money and/or legitimate contractual payments connected to rugby-related services, sponsorship or endorsements and/or similar payments.

**Bet** Placing, accepting, laying and/or otherwise entering into any form of wager, bet and/or financial speculation in the expectation of a prize of monetary value, subject to a future occurrence related to an Event (or any aspect thereof). The foregoing shall include, without limitation, a wager, bet

and/or financial speculation on a number of events or occurrences (for example, a multi or accumulator bet). A **Prohibited Bet** shall be any conduct in contravention of Regulation 6.3.1.

**Connected Person** Any International Player, Contract Player, International Match Official, Contract Player Support Personnel, any coach, trainer, selector, health professional, analyst, team official, administrator, owner, shareholder, director, executive, staff member and/or any other person involved with and/or engaged in relation to the Game by a Union or its National Representative Team and shall include any Union/Association/World Rugby panel of Match Officials at International Match and/or Contract Player level, Disciplinary Personnel, any Agent and/or representative of an International Player, Contract Player or Contract Player Support Personnel and/or family member and/or associate of any of the foregoing (to the extent that such family member/associate falls under the jurisdiction of a Union, Rugby Body and/or World Rugby) and/or any other individual or entity involved in the organisation, administration and/or promotion of the Game at International Match and/or Contract Player level and/or the training of persons participating in the Game at International Match and/or Contract Player level.

**Connected Event** An Event with which a Connected Person and/or the National Representative Team and/or Union/Association/World Rugby Match Official panel (as applicable) is involved with, connected to or engaged with. For the avoidance of doubt where the Event is, for example, an International Match forming part of an International Tournament and/or Series of International Matches, every other International Match in that International Tournament and/or Series of International Matches shall also be a Connected Event.

**Contract Player Support Personnel** A Connected Person who is involved with and/or engaged by a Contract Player, a Club, Rugby Body, team and/or Event which includes Contract Players and shall include the teammates and opponents of Contract Players, the Match Officials and Disciplinary Personnel appointed to an Event which includes Contract Players, the support personnel of such Contract Players and Match Officials and the directors, officers and personnel of Unions, Clubs and Rugby Bodies which engage Contract Players (and including without limitation the owners of Clubs and Rugby Bodies, save where the owner is a Union).

**Disciplinary Personnel** A Judicial Officer, Citing Commissioner, Disciplinary Committee, Appeal Committee, Judicial Committee and/or Post-Hearing Review Body member, disciplinary officer, and/or anti-doping and/or other disciplinary personnel.

**Event** A Match, tournament, Series of Matches, league, and/or competition at any level of the Game including, for the avoidance of doubt, a Connected Event.

**Fix** Fixing, contriving in any way and/or otherwise influencing improperly the outcome of an Event and/or any aspect of an Event and/or being party to any effort to fix, contrive in any way and/or otherwise influence improperly

the outcome or any aspect of an Event. The foregoing shall include, without limitation, improperly ensuring that a particular incident(s) takes place or does not take place during an Event(s) or at a particular time or juncture during an Event(s) and improperly manipulating the scoring or any other aspect of an Event(s).

**Inside Information** Any non-public information relating to any Event including any aspect thereof that a Connected Person possesses by virtue of his position within the Game. Such information includes, but is not limited to, relevant information regarding a Participant(s), conditions, tactic(s) and/or strategy(ies), selection, injury(ies), and/or any other information relating to the likely performance of a Participant(s) and/or outcome of an Event including any aspect thereof, and/or any other relevant information in relation to an Event which is known by a Connected Person(s) but which is not already published or a matter of public record, which is not readily acquired by an interested member of the public and/or disclosed according to the rules and regulations governing the Event.

**International Player** A Player who participates in an International Match(es).

**Match Official** A referee, assistant referee, touch judge, television match official, in-goal referee, fourth and fifth match official and any other person involved in the officiating of a Match. An **International Match Official** is a Match Official who officiates (or has officiated) in an International Match(es).

**Mobile Communications Device** Any device, electronic or otherwise, which may be used to communicate with another person remotely and without significant delay including, without limitation, telephones, computers, pagers, personal digital assistants, tablet computers, handheld transceivers and any similar device hereinafter invented.

**Multi-Sport Games** The Olympic Games (including the Youth Olympic Games), the Commonwealth Games (including the Youth Commonwealth Games), the Pan-Pacific Games, the Asian Games and all other similar events featuring the Game along with at least two other sports.

**Participant** A Player, Match Official, Union, National Representative Team and/or team involved in an Event(s).

**Provisional Suspension** has the meaning set out in Regulation 6.8.2.

**Suspension** A suspension of a Connected Person for a specified period of time as determined and imposed by a Judicial Officer or Judicial Committee or Appeal Committee from involvement with the Game as set out in Regulation 6.10.5(d).

**Substantial Assistance** To be entitled to any benefit pursuant to Regulation 6.10.4(g), a Connected Person must: (a) fully disclose in a signed witness statement all information that he possesses in relation to an Anti-Corruption Breach(es); and (b) cooperate with the investigation and adjudication of any case related to that information, including, for example,

presenting testimony at a hearing if requested to do so by World Rugby and/or a Union. Further, the information provided must be credible and must comprise an important part of any case that is initiated or, if no case is initiated, must have provided a sufficient basis on which a case could have been brought.

**Unsuitable Conduct** Corruption and/or conduct involving dishonesty and/or fraud (including without limitation where the person is the subject of an investigation with respect to these Anti-Corruption Regulations) save where the person: (i) has been found in accordance with the process set out in Regulation 6.9 and 6.11 (as applicable) not to have committed an Anti-Corruption Breach; and/or (ii) has completed a sanction(s) (including without limitation a Provisional Suspension) pursuant to these Anti-Corruption Regulations, including all rehabilitation, education and other requirements, as applicable; and/or (iii) has completed an equivalent or higher sanction under other regulations and/or laws (including without limitation in relation to another sport) to that which would reasonably have been imposed had the matter been heard pursuant to these Anti-Corruption Regulations (taking into account, as appropriate, relevant jurisprudence); and (iv) has been sufficiently rehabilitated.

**Unsuitable Person** A person so deemed pursuant to Regulation 6.4.

### 6.3 Anti-Corruption Breaches

A Connected Person commits an Anti-Corruption Breach if he engages in and/or Attempts to engage in any of the conduct set out in Regulations 6.3.1 to 6.3.4 and/or commits any other breach of the requirements of these Anti-Corruption Regulations. Accordingly, it is not necessary that intent, fault, negligence and/or knowing commission of an Anti-Corruption Breach on the Connected Person's part be demonstrated in order to establish that an Anti-Corruption Breach has been committed.

#### 6.3.1 Prohibited Betting

All Connected Persons

- (a) No Connected Person shall, directly or indirectly, Bet and/or Attempt to Bet on the outcome or any aspect of any Connected Event and/or receive and/or Attempt to receive part or all of the proceeds of any such Bet and/or any other Benefit in relation to a Bet.
- (b) No Connected Person shall and/or shall Attempt, directly or indirectly, to solicit, offer, induce, entice, instruct, persuade, encourage, agree with and/or facilitate any other party to Bet and/or Attempt to Bet on the outcome or any aspect of any Connected Event.

Contract Player(s) and Contract Player Support Personnel

- (c) No Contract Player or Contract Player Support Personnel shall, directly or indirectly, Bet and/or Attempt to Bet on the outcome and/or any aspect of any Event and/or receive and/or Attempt to receive part



or all of the proceeds of any such Bet and/or any other Benefit in relation to a Bet.

- (d) No Contract Player or Contract Player Support Personnel shall and/or shall Attempt, directly or indirectly, to solicit, induce, entice, instruct, persuade, encourage, agree with and/or facilitate any other person to Bet and/or Attempt to Bet on the outcome or any aspect of any Event.

#### Connected Persons involved<sup>1</sup> in Multi-Sport Games

- (e) No Connected Person involved in a Multi-Sports Games shall, directly or indirectly, Bet and/or Attempt to Bet on the outcome or any aspect of that Multi-Sport Games (including for the avoidance of doubt other sports) and/or receive and/or Attempt to receive part or all of the proceeds of any such Bet and/or any other Benefit in relation to a Bet.
- (f) No Connected Person involved in a Multi-Sports Games shall and/or shall Attempt, directly or indirectly, to solicit, offer, induce, entice, instruct, persuade, encourage, agree with and/or facilitate any other party to Bet and/or Attempt to Bet on the outcome or any aspect of that Multi-Sport Games (including for the avoidance of doubt other sports).

#### 6.3.2 **Corruption related to Fixing**

No Connected Person shall:

- (a) Fix and/or Attempt to Fix.
- (b) Or shall Attempt, directly or indirectly, to solicit, offer, induce, entice, instruct, persuade, encourage, agree, give, pay for, receive and/or facilitate a Benefit to Fix and/or Benefit to Attempt to Fix.
- (c) For Benefit fail to perform to the best of his abilities (including in the future) in relation to an Event(s) including any aspect thereof.
- (d) Solicit, offer, induce, entice, instruct, persuade and/or encourage another Connected Person to fail to perform to the best of their abilities in relation to an Event(s).

#### 6.3.3 **Misuse of Inside Information**

No Connected Person shall or shall Attempt directly or indirectly to:

- (a) Use Inside Information for the purposes of Betting whether by themselves or by or via another person and/or entity;
- (b) Disclose Inside Information to any person (with or without Benefit) before and/or during an Event where the Connected Person knows

---

<sup>1</sup> *Comment: Involved is intended to refer, for example, to participation in the Multi-Sport Games itself as a competitor or official and/or presence at the Multi-Sport Games for the purposes of preparation and/or selection of teams or officials for such Multi-Sport Games.*

and/or may reasonably be expected to know that disclosure of the Inside Information could be used in relation to Betting.<sup>2</sup>

- (c) Give and/or receive Benefit for the provision of Inside Information (notwithstanding whether any Inside Information is actually provided).
- (d) Solicit, offer, induce, entice, instruct, persuade, encourage and/or facilitate the giving and/or receiving of Benefit for the provision of Inside Information (notwithstanding whether any Inside Information is actually provided).
- (e) Solicit, offer, induce, entice, instruct, persuade, encourage, pay for and/or facilitate the breach of any of the foregoing provisions of this Regulation 6.3.3.

#### 6.3.4 **General corruption offences**

No Connected Person shall and/or shall Attempt directly or indirectly to:

- (a) Solicit, offer, induce, entice, instruct, persuade, encourage and/or facilitate the giving and/or receiving of Benefit in relation to an Event improperly and/or in circumstances which the Connected Person knows and/or may reasonably be expected to know could bring the Connected Person and/or the Game into disrepute and/or may pose a threat to the integrity of the Game.
- (b) Obstruct and/or delay any investigation by the Anti-Corruption Officer and/or tamper with, obstruct, delay, and/or destroy any evidence, potential evidence, documentation and/or information which may be relevant to an Anti-Corruption Breach (actual or potential) and/or an investigation into anti-corruption or pursuant to these Anti-Corruption Regulations.

#### 6.3.5 **Responsibilities of Connected Persons**

- (a) Connected Persons shall report to the Anti-Corruption Officer at the first available opportunity full details of any approach, invitation, offer, solicitation, inducement, enticement, instruction, persuasion, encouragement, payment and/or facilitation to them and/or to any other Connected Person of which they have knowledge with respect to Prohibited Betting and/or Attempted Prohibited Betting, Fixing, Attempted Fixing, the provision of Inside Information for such purposes and/or any other conduct, information and/or credible suspicion in relation to any conduct which may breach any provision of and/or be relevant with respect to these Anti-Corruption

---

<sup>2</sup> *Comment: This Regulation shall not prohibit a disclosure of Inside Information to the general public at large (for example without limitation, in a live media interview or in the news section of a Union's website) such that the information thereby ceases to be Inside Information nor shall it prohibit a disclosure of Inside Information to a close personal associate provided that the Connected Person is aware of and complies with Regulation 6.1.4(a) and where in the circumstances it is reasonable for the Connected Person to expect that the Inside Information can be disclosed in confidence and that it will not be used in relation to Wagering. Subject to the foregoing, this Regulation shall prohibit a disclosure, for example, to journalists, members of the media, online social network contacts and/or other persons where the Connected Person knows and/or may reasonably be expected to know that disclosure of the Inside Information could be used in relation to Wagering.*

Regulations and/or which may otherwise pose a threat to the integrity of the Game. For the avoidance of doubt, Connected Persons shall be required to report any new information or suspicion pursuant to the foregoing including in circumstances where the Connected Person has already made a report to the Anti-Corruption Officer and/or is aware that a report has been made by another person and/or is otherwise aware that the matter has come to the attention of the Anti-Corruption Officer. World Rugby shall permit reports to be made anonymously.

- (b) In the event that a Connected Person fails to comply with Regulation 6.3.5(a) the Connected Person shall be liable to receive the same sanction, as if s/he had committed the Anti-Corruption Breach himself.
- (c) Upon request by the Anti-Corruption Officer, Connected Persons shall cooperate accurately, completely and without undue delay with, and shall provide all necessary assistance to, the Anti-Corruption Officer with respect to any matter pursuant to these Anti-Corruption Regulations (including answering the questions of and furnishing the Anti-Corruption Officer with, all relevant and/or requested documentation and information, including, without limitation, all telephone records, bank account, credit card and transaction details, betting account records, internet and email records, computers and hard drives and other electronic information storage devices and documents). Connected Persons shall ensure that any such documents are available and/or can be obtained.
- (d) Connected Persons shall attend any hearings (either in person or by telephonic means as directed by the Judicial Officer, Judicial Committee and/or Appeal Committee) save where they have not been given reasonable notice and/or where they have other compelling justification to the satisfaction of the Judicial Officer, Judicial Committee and/or Appeal Committee.
- (e) Connected Persons shall, and shall make all efforts within their power to ensure that their family members/associates shall, keep all matters related to a report pursuant to Regulation 6.3.5(a) and/or to a request pursuant to Regulation 6.3.5(c) and/or any other proceedings pursuant to these Anti-Corruption Regulations confidential save as otherwise required in accordance with these Anti-Corruption Regulations, applicable laws and/or regulations.
- (f) World Rugby may issue a direction prohibiting and/or restricting the use of Mobile Communications Devices on the day of an International Match for certain Connected Persons involved with the conduct of the International Match (without prejudice to the ability of a Union or Tournament Organiser to issue such a direction in its own jurisdiction) and in such case all Connected Persons shall comply with the direction(s) of World Rugby. Before such direction is issued World Rugby shall advise and as appropriate, consult in advance with the

Host Union or Tournament Organiser with regard to logistics and implementation of the directive(s).

- (g) Connected Persons involved in a Multi-Sports Games shall not breach any rules and/or regulations with respect to betting and/or corruption of those Multi-Sports Games.
- (h) For the avoidance of doubt a failure to comply with any aspect of this Regulation 6.3.5 shall constitute an Anti-Corruption Breach.

6.3.6 The following shall not be relevant to the determination as to whether an Anti-Corruption Breach has been committed (although they may be relevant to the issue of the appropriate sanction to be imposed pursuant to Regulation 6.10):

- (a) Whether the Connected Person who is alleged to have committed an Anti-Corruption Breach was participating in the particular Event(s) in relation to which the conduct is alleged;
- (b) The outcome of the Event (and/or any aspect thereof) in relation to which such Bet was made and whether it was intended;
- (c) Whether or not any Benefit was actually given or received;
- (d) The nature and/or outcome of any Bet(s) in issue;
- (e) An absence of or unusual evidence with respect to a Connected Person's lack of effort and/or poor performance in an Event and/or aspect thereof (however, any such evidence may be offered to support an allegation regarding a breach of these Anti-Corruption Regulations);
- (f) Whether or not a Connected Person's efforts or performance (if any) in relation to the Event(s) in issue were (or could be expected to be) affected by the acts or omissions in question;
- (g) Whether or not any of the results and/or aspects of the Event(s) in issue were (or could be expected to be) affected by the acts or omissions in question;
- (h) Whether or not the manipulation included a violation of a technical rule and/or regulation of World Rugby, a Union and/or the Tournament Organiser; and
- (i) Whether or not the Event was attended by a representative of the Union, Association, Tournament Organiser, World Rugby or other competent authority.

6.3.7 Any act or omission that is proven to amount to aiding, abetting or an Attempt to commit an Anti-Corruption Breach shall be treated as if an Anti-Corruption Breach has been committed whether or not such act or omission resulted in an Anti-Corruption Breach.

6.3.8 It shall be a valid defence by a Connected Person to an allegation of an Anti-Corruption Breach that the Connected Person has: (i) promptly made a report in accordance with Regulation 6.3.5(a); and/or (ii) demonstrates that such conduct was the result of a significant threat to the life and/or safety of the Connected Person or another person.

### **6.4 Unsuitable Persons**

6.4.1 The Anti-Corruption Officer may make an application to a Judicial Officer to deem any person who is and/or is seeking to become a Connected Person to be an Unsuitable Person where the Anti-Corruption Officer has reasonable grounds to believe that the person may be and/or may have been involved in any Unsuitable Conduct.

6.4.2 The Anti-Corruption Officer, or his nominee, may conduct an investigation(s) in relation to any person suspected of being an Unsuitable Person prior to making the application to the Judicial Officer pursuant to 6.4.1 above and/or for a Provisional Suspension to be applied pending final determination of the matter. The Anti-Corruption Officer shall consult with the relevant Union (as appropriate) and provide the person the subject of the investigation with the opportunity to be heard and represented. Any failure to cooperate fully with and/or to provide full, accurate and prompt assistance to the Anti-Corruption Officer, or his nominee, in relation to such investigation shall be grounds for a Judicial Officer to make a determination that the person is an Unsuitable Person.

6.4.3 The person the subject of the application pursuant to Regulation 6.4.1 (the "Subject") shall be given notice of such application and shall have an opportunity to present his case. Save where this Regulation 6.4 requires otherwise, Regulation 6.9 shall apply to hearings regarding Unsuitable Persons.

6.4.4 Following consideration of the evidence presented to him, the Judicial Officer shall either (i) impose a Provisional Suspension (where sought by the Anti-Corruption Office) or, (ii) deem a Subject to be an Unsuitable Person where he considers that there are reasonable grounds to believe that the Subject may be and/or may have been involved in any Unsuitable Conduct.

6.4.5 The Anti-Corruption Officer shall notify the Unsuitable Person and the Union(s) concerned in writing advising them of the decision of the Judicial Officer. Where a person has been deemed to be an Unsuitable Person he may not, following receipt of notification, be involved in the Game as a Connected Person. Unions shall acknowledge and enforce any such decision and its consequences forthwith.

6.4.6 A person who has been deemed an Unsuitable Person may issue a notice of appeal within fourteen (14) days of receipt of the notification of the decision to the Appeal Panel Chairman. The appeal shall be heard by an Appeal Committee pursuant to the procedure set out in Regulation 6.11.

- 6.4.7 Where the Appeal Committee confirms the decision that the person is an Unsuitable Person or where the Unsuitable Person does not appeal he may re-apply to a Judicial Officer after six (6) months of the date of the written decision of the Appeal Committee or Judicial Officer, as applicable, with evidence in relation to his rehabilitation from the Unsuitable Conduct which led to him being deemed to be an Unsuitable Person. The processes set out in Regulations 6.4.2 to 6.4.6 shall apply in relation to all subsequent applications.
- 6.4.8 Any breach by a Subject and/or an Unsuitable Person of a Provisional Suspension and/or Regulation 6.4.4 may result in a Judicial Officer (following an application by the Anti-Corruption Officer) increasing the period before which the Unsuitable Person may not re-apply pursuant to this clause by up to two (2) years.
- 6.4.9 Any person who is subject to a Suspension (including for these purposes a Provisional Suspension) for an Anti-Corruption Breach (including for these purposes pursuant to a decision under the anti-corruption regulations, or equivalent, of a Union or another sporting body recognised by World Rugby in accordance with Regulation 6.14) shall, automatically be deemed an Unsuitable Person for the duration of his Suspension or Provisional Suspension.
- 6.4.10 Judicial Officers and Appeal Committees, as applicable, shall have full discretion in relation to a decision to deem a person to be an Unsuitable Person, maintain a person as an Unsuitable Person and/or impose any conditions in deeming a person to be a suitable person and neither he, they, World Rugby nor any Union shall be liable to any person and/or entity with respect to such decision(s).

## 6.5 Responsibilities of Unions

These Anti-Corruption Regulations shall apply to World Rugby and each Union and each of its and their constituents. Each Union is responsible for ensuring (and must ensure) that:

- (a) It furnishes the Anti-Corruption Officer with full details of any matter which may relate to an Anti-Corruption Breach, a potential Anti-Corruption Breach, a person to whom Regulation 6.4 may apply and/or any other matter related to the subject of these Anti-Corruption Regulations as soon as practicable and that it assists the Anti-Corruption Officer with respect to any investigation, hearing and/or other matter pursuant to these Anti-Corruption Regulations.
- (b) It has in place anti-corruption regulations which reflect the principles of these Anti-Corruption Regulations at national level in accordance with applicable laws. However, nothing in these Anti-Corruption Regulations shall prevent a Union from imposing more restrictive regulations than these Anti-Corruption Regulations within its jurisdiction including for reasons of compliance with local laws and regulations.

- (c) It shall use all efforts in its power to obtain the written acknowledgement of all Connected Persons acknowledging that they are bound by and shall comply with these Anti-Corruption Regulations and the anti-corruption regulations of the Union.
- (d) It shall establish rules and procedures such that all Connected Persons consent to the dissemination of their private data as required or authorised by these Anti-Corruption Regulations and/or the anti-corruption rules of the Union and/or Rugby Body and shall use its best endeavours to obtain the consent of Connected Persons in relation to the collection, processing, disclosure and use of data relating to Connected Persons and their activities.
- (e) It takes appropriate action to inform each of its Contract Players, Contract Player Support Personnel and Connected Persons of these Anti-Corruption Regulations and its anti-corruption regulations and their obligations thereunder. To combat corrupt gambling practices and promote the integrity of sport, each Union shall co-operate with World Rugby and in particular with its educational initiatives and develop, plan, implement, evaluate and monitor information and education programmes to facilitate compliance in its jurisdiction with these Anti-Corruption Regulations and its own anti-corruption regulations.
- (f) It keeps the Anti-Corruption Officer fully informed in relation to any intelligence it has in relation to a breach(es) and/or potential breach(es) of these Anti-Corruption Regulations (and/or the Union's anti-corruption regulations) arising from or out of its jurisdiction; that it consults and cooperates with the Anti-Corruption Officer in advance with respect to the action it intends to take; and that it takes appropriate action with respect to breach(es) and/or potential breach(es) of these Anti-Corruption Regulations and its anti-corruption regulations. The Anti-Corruption Officer shall also share appropriate information with the Union(s) with respect to matters subject to these Anti-Corruption Regulations and/or involving the Unions' members.
- (g) It nominates an anti-corruption officer for the purposes of managing the Union's obligations under these Anti-Corruption Regulations and its own anti-corruption regulations, including the reporting and information-sharing requirements set out herein.
- (h) It establishes relationships with appropriate bodies in its jurisdiction with respect to anti-corruption, including any betting operators, police, any gambling authorities, its National Olympic Committee and other competent bodies and facilitates where appropriate, the extension of such relationships to World Rugby.
- (i) It does not permit any Betting related to age-grade National Representative Teams (being ordinarily persons under the age of 18) or sponsorship by organisations promoting Betting in connection with

such age grade teams or Match Officials of Matches involving such teams, under its jurisdiction.

## **6.6 Burden and standard of proof**

6.6.1 The Anti-Corruption Officer (who may be represented by counsel) shall have the burden of establishing that an Anti-Corruption Breach has been committed and/or that a person is an Unsuitable Person, as applicable. The standard of proof in all matters under these Anti-Corruption Regulations shall be the balance of probabilities.

6.6.2 Where these Anti-Corruption Regulations place the burden of proof upon the Connected Person alleged to have committed an Anti-Corruption Breach and/or person subject to Unsuitable Person proceedings to rebut a presumption or establish facts or circumstances, the standard of proof shall also be the balance of probabilities.

## **6.7 Investigations**

6.7.1 Any breach, allegation or suspicion of a breach of these Anti-Corruption Regulations shall be referred in the first instance to the Anti-Corruption Officer for investigation and possible charge in accordance with Regulation 6.7.5.

6.7.2 The Anti-Corruption Officer or his nominee may conduct investigations into the activities of any Connected Person that he reasonably suspects may have committed an Anti-Corruption Breach under these Anti-Corruption Regulations. Such investigations may be conducted in conjunction with, and/or information obtained in such investigations may be shared with, Unions, Tournament Organisers and/or other relevant authorities (including criminal, administrative, professional and/or judicial authorities) and all Connected Persons and Unions must cooperate fully with such investigations and failure to cooperate with any such investigation may itself constitute Misconduct under the Regulations. The Anti-Corruption Officer shall have discretion, where he deems it appropriate, to stay his own investigation pending the outcome of investigations being conducted by a Union and/or other relevant authorities.

6.7.3 In connection with any investigation, if the Anti-Corruption Officer reasonably suspects that a Connected Person (or a third party whose actions may be imputed to a Connected Person) has committed an Anti-Corruption Breach, he may make a written demand to the Connected Person (a 'Demand') to provide him with any information that is reasonably related to the alleged Anti-Corruption Breach, including, without limitation:

- (a) Copies or access to all records relating to the alleged breach (such as without limitation telephone records, bank account, credit card and transaction details, internet and email records, betting account records, computer hard drives and other electronic information storage devices and documents); and/or



- (b) A written statement made by the Connected Person setting out in detail all of the facts and circumstances of which the Connected Person is aware with respect to the alleged Anti-Corruption Breach.

The Connected Person shall cooperate fully with any such Demand, including by furnishing such information within such reasonable period of time as may be determined by the Anti-Corruption Officer, which ordinarily, should be no earlier than fourteen (14) days of the Connected Person's receipt of the Demand. Where appropriate, the Connected Person may seek a reasonable extension of time from the Anti-Corruption Officer by providing the Anti-Corruption Officer with clear and justifiable reasons to support such an extension.

6.7.4 Any information furnished to the Anti-Corruption Officer will not be used for any reason other than pursuant to these Anti-Corruption Regulations and/or the anti-corruption regulations of a Union and will be kept strictly confidential except when:

- (a) It becomes necessary to disclose such information in support of a charge of breach of the Anti-Corruption Regulations;
- (b) Such information is already published or within the public domain and readily acquired by an interested member of the public, or
- (c) Disclosed according to the rules and regulations governing the relevant Event; and/or
- (d) It becomes necessary to disclose such information where it may also amount to or evidence infringements (actual or potential) of applicable laws or regulations. In such circumstances the Anti-Corruption Officer and/or World Rugby may conduct investigations in relation to such matter in conjunction with and/or may share information relating to the matter with the competent authorities (including any applicable police, taxation, fraud, criminal intelligence or other authorities), whether pursuant to formal information-sharing information agreements with such authorities or otherwise.

Excluding where required by law pursuant to (d) above, the Anti-Corruption Officer shall not disclose any information which he considers likely to endanger the health and/or safety of any person and/or the interests of the Game.

6.7.5 Where, following an investigation, the Anti-Corruption Officer (in consultation with the CEO) determines that there is a case to answer under these Anti-Corruption Regulations then the matter shall be referred to a Judicial Committee or Judicial Officer for consideration. The Connected Person and his Union shall be notified in accordance with Regulation 6.7.6. The decision of the Anti-Corruption Officer to investigate and/or bring a charge(s) for an Anti-Corruption Breach(es) shall be final.

6.7.6. The Connected Person and their Union shall be sent the charge(s) relating to the Anti-Corruption Breach(es) which should include the following information (the '**Notice of Charge**')

- (a) That the Connected Person has a case to answer under Regulation 6.3;
- (b) The specific Anti-Corruption Breach(es) which the Connected Person is alleged to have committed;
- (c) Details of the alleged acts and/or omissions relied upon in support of the charge;
- (d) The range of sanctions applicable under the Anti-Corruption Regulations;
- (e) The matters relating to Provisional Suspension specified at Regulation 6.8 (as applicable); and
- (f) The matters relating to responding to a Notice of Charge specified in Regulation 6.7.7.

6.7.7 The Notice of Charge shall specify that, if the Connected Person wishes to exercise his right to a hearing he shall respond to the Notice of Charge in writing within fourteen (14) days of his receipt of the Notice of Charge indicating whether he admits or denies the allegations against him and/or whether he admits the allegations against him but intends to make submissions with respect to sanction at a hearing and/or in writing. If the Connected Person does not respond to the Notice of Charge within fourteen (14) days of receipt denying or admitting the allegations against him but indicating his intention to make submissions with respect to sanctions at a hearing and/or in writing, the Connected Person shall be deemed:

- (a) To have waived his entitlement to a hearing;
- (b) To have admitted that he has committed the Anti-Corruption Breach(es) alleged in the Notice of Charge;
- (c) To have acceded to the range of applicable sanctions specified in these Anti-Corruption Regulations.

In such circumstances the matter shall be referred to the Chairman of the Judicial Panel in accordance with Regulation 18.2.1 to appoint a Judicial Officer to proceed to determine the matter on the papers. The Connected Person shall be Provisionally Suspended forthwith pending the determination of the matter by the appointed Judicial Officer, (notwithstanding the procedure set out in Regulation 6.8), and the Anti-Corruption Officer shall notify the Connected Person accordingly. The Anti-Corruption Officer shall be entitled to make written submissions to the Judicial Officer and to adduce such evidence as he considers appropriate.

6.7.8 If the Connected Person responds to the Notice of Charge within fourteen (14) days of receipt denying the allegations against him, his response shall set out as a minimum a summary of the grounds upon which he denies those allegations. In any event, where the Connected Person denies the allegations or admits the allegations but indicates his intention to make

submissions with respect to sanction at a hearing and/or in writing, the case shall be referred to the Chairman of the Judicial Panel in accordance with Regulation 18.2.1 to appoint a Judicial Committee or Judicial Officer and shall be proceeded with in accordance with Regulation 6.9 (notwithstanding the procedure with respect to Provisional Suspension set out in Regulation 6.8).

6.7.9 Notwithstanding Regulations 6.7.7, 6.7.8 and without prejudice to Regulation 6.12, the Anti-Corruption Officer where he considers it appropriate, and where the relevant Union agrees, may refer the conduct of an investigation(s) and/or a hearing(s) pursuant to these Anti-Corruption Regulations arising from its jurisdiction to the relevant Union. World Rugby shall be a notice party in any such proceedings and shall provide assistance, where required, to the Union. The Anti-Corruption Officer may only take such action prior to the commencement of the substantive hearing before a Judicial Committee or Judicial Officer. The Anti-Corruption Officer, in consultation with the relevant Union, may also assume the conduct of an investigation(s) and/or hearing(s) under the Union's anti-corruption rules where the person(s) the subject of such investigation(s) and/or hearing(s) is also a Connected Person(s) the subject of an investigation(s) and/or hearing(s) pursuant to these Anti-Corruption Regulations. Unless World Rugby directs otherwise, the Union shall maintain any action taken pursuant to this Regulation 6.7.9 confidential.

### **6.8 Provisional Suspension**

6.8.1 Where the Anti-Corruption Officer issues a Notice of Charge to a Connected Person he may apply to a Judicial Committee or Judicial Officer to impose a Provisional Suspension on such Connected Person pending determination of the case at a hearing. The Anti-Corruption Officer shall notify the Connected Person of his application who shall be informed of the time and date of the hearing in respect of the Provisional Suspension application. The hearing shall ordinarily not be conducted until the Connected Person has confirmed receipt of the notification of the Provisional Suspension hearing. The hearing shall be conducted in accordance with Regulation 6.9. The Judicial Committee or Judicial Officer shall impose a Provisional Suspension on the Connected Person where the Anti-Corruption Officer has demonstrated on the balance of probabilities that there is a prima facie case that the Connected Person has committed an Anti-Corruption Breach. Such Provisional Suspension shall remain in place pending the final determination of the matter by a Judicial Committee or Judicial Officer.

6.8.2 Provisional Suspension means the Connected Person or other person is barred temporarily from playing, training as part of any team or squad, officiating, coaching, selecting, administering and/or otherwise participating or being involved in any capacity in the Game or participating in any function, event or activity that is authorised, organised, sanctioned, recognised or supported in any way by World Rugby, an Association, a Union or Rugby Body prior to the final decision at a disciplinary hearing. Unions and Rugby Bodies shall take all reasonable steps within their

powers to give effect to this Regulation 6.8.2 where they have the jurisdiction to do so.

- 6.8.3
- (a) Where a Provisional Suspension is imposed and respected by the Connected Person he shall receive a credit for such period of Provisional Suspension against any period of suspension which may ultimately be imposed.
  - (b) If a Connected Person voluntarily accepts a Provisional Suspension in writing from the Anti-Corruption Officer and thereafter refrains from competing or participating in the Game in any way, the Connected Person shall receive a credit for such period of voluntary Provisional Suspension against any period of suspension which may ultimately be imposed.
  - (c) No credit against a period of suspension shall be given for any time period before the effective date of the Provisional Suspension or voluntary Provisional Suspension regardless of whether the Connected Person elected not to compete or was suspended by his Union.

## 6.9 Disciplinary Procedures

- 6.9.1 The general procedures relating to hearings before Judicial Officers and Judicial Committees contained in Regulation 18 Appendix 1 shall apply to any matter arising under these Anti-Corruption Regulations subject to any provisions to the contrary herein.
- 6.9.2 The Judicial Officer, Judicial Committee and/or Appeal Committee as appropriate, shall not be bound by any jurisdiction's judicial rules governing the admissibility of evidence. Instead, facts relating to an alleged Anti-Corruption Breach may be established by any reliable means, as determined in the sole discretion of the Judicial Officer, Judicial Committee and/or Appeal Committee, as appropriate.
- 6.9.3 Further, notwithstanding that such conduct may amount to a separate Anti-Corruption Breach, the, Judicial Committee, Judicial Officer and/or Appeal Committee, as appropriate, may draw an inference adverse to the Connected Person alleged to have committed an Anti-Corruption Breach based on his failure and/or refusal to cooperate fully, accurately and promptly with and/or to provide full, accurate and prompt assistance to the Anti-Corruption Officer and/or his failure and/or refusal to attend the hearing (in person or by telephonic means as directed by the Judicial Officer, Judicial Committee and/or Appeal Committee, as appropriate) of which he has been given reasonable notice and/or to give full and accurate evidence as directed.
- 6.9.4 Where two or more Connected Persons are alleged to have committed Anti-Corruption Breaches which arise from the same incident or set of facts or where there is a clear link between the two or more cases, such cases may be dealt with at the same hearing before the Judicial Officer or Judicial

Committee (or in the case of an appeal, the Appeal Committee), provided there is no prejudice to any such Connected Person.

6.9.5 Save where the Judicial Officer or the Judicial Committee (or in the case of an appeal, an Appeal Committee) orders otherwise, the hearing and all submissions and documents shall be in English or translated or interpreted into English at the cost of the party presenting such evidence, submissions or documents. The hearing shall take place in such location and in such form as the Judicial Officer or Judicial Committee (or in the case of an appeal, the Appeal Committee) shall direct, taking into account any submissions from the parties.

6.9.6 The Judicial Officer or Judicial Committee (and in the case of an appeal, the Appeal Committee) shall issue its decision in writing, with reasons, through World Rugby to the Anti-Corruption Officer and the Connected Person and his Union as soon as practicable after the hearing. The written decision of the Judicial Officer or Judicial Committee shall set out and explain:

- (a) Its findings with respect to whether any Anti-Corruption Breach(es) has/have been committed;
- (b) Its findings as to what sanctions, if any, are to be imposed on the Connected Person and, in the case of a period of Suspension, the dates;
- (c) The rights of appeal as set out in Regulation 6.11.

In the case of an appeal the written decision of the Appeal Committee shall set out its decision in relation to the appeal and shall indicate whether the sanctions, if any, imposed by the Judicial Officer or Judicial Committee are to be varied and, if so, shall set out what sanctions are to be imposed on the Connected Person and in the case of a Period of Suspension, the dates thereof.

6.9.7 Subject only to the appeal provisions set out in Regulation 6.11 the decision of a Judicial Officer or Judicial Committee under these Anti-Corruption Regulations shall be the full, final and complete disposition of the matter and shall be binding on all parties.

### **6.10 Sanctions**

6.10.1 Where it is determined that an Anti-Corruption Breach has been committed, the Judicial Committee or Judicial Officer (and in the case of an appeal as applicable, the Appeal Committee) shall impose an appropriate sanction upon the Connected Person from the range of permissible sanctions described in Regulation 6.10.2. In order to determine the appropriate sanction applicable in each case, the Judicial Committee or Judicial Officer (and in the case of an appeal as applicable, the Appeal Committee) in determining the relative seriousness of the offence shall take the aggravating and mitigating features of offending set out in Regulation 6.10.3 and 6.10.4 into account and shall detail the effect of such factors on the final sanction in the written decision.

6.10.2 The range of sanctions applicable to an Anti-Corruption Breach is set out hereunder.

Anti-Corruption Breach	Range of Sanctions per offence	Additional Sanctions
<b>Prohibited Betting (Reg. 6.3.1)</b>	Minimum: reprimand and/or warning  Maximum: Life Suspension	<b>AND (in all cases)</b> The Judicial Committee or Judicial Officer shall have the discretion to impose a fine on the Connected Person arising out of, or in connection with the Anti-Corruption Breach(es).
<b>Corruption Related to Fixing (Reg.6.3.2)</b>	Minimum: reprimand and/or warning  Maximum: Life Suspension	<b>AND (in all cases)</b> Appropriate further options including without limitation the cancellation of sports results / events, demotion, points reduction, return of rewards, replay of fixtures (for example in cases of Match Official corruption) where risk of fraud has been established or identified, withdrawal of accreditation, exclusion from Match venues and/or official Player environs, as appropriate.
<b>Misuse of Inside Information (Reg.6.3.3)</b>	Minimum: reprimand and/or warning  Maximum: Life Suspension	
<b>General Corruption Offences (Reg.6.3.4)</b>	Minimum: reprimand and/or warning  Maximum: Life Suspension	

6.10.3 The aggravating features of the offending in connection with an Anti-Corruption Breach shall include the following:

- (a) Whether the Connected Person has a high degree of fault<sup>3</sup> in relation to the Anti-Corruption Breach;
- (b) Whether the Connected Person has previously been found guilty of any similar Anti-Corruption Breach under these Anti-Corruption Regulations or any Misconduct regulations, whether by World Rugby, a Union or a Tournament Organiser, or of a similar offence under any other laws and/or regulations;
- (c) Where the amount of any Benefit, directly or indirectly received by the Connected Person as a result of the offence(s), is substantial and/or where the sums of money otherwise involved in the Anti-Corruption Breach(es) were substantial;
- (d) Where the Anti-Corruption Breach substantially damaged (or had the potential to damage substantially) the commercial value and/or the public interest in the relevant Event(s);

<sup>3</sup> Comment: For example, a high degree of fault may be an orchestrated Fix or passing of Inside Information for Benefit.

- (e) Where the Anti-Corruption Breach affected (or had the potential to affect) the result of the relevant Event(s);
- (f) Where the welfare of a Connected Person or any other person has been endangered as a result of the Anti-Corruption Breach;
- (g) Where the Anti-Corruption Breach involved more than one Connected Person;
- (h) Where the Connected Person has not cooperated with any investigation and/or the process (notwithstanding that this may amount to a separate Anti-Corruption Breach); and/or
- (i) Any other aggravating factor(s) that the Judicial Committee or Judicial Officer (or in the case of an appeal as applicable, the Appeal Committee) considers relevant and appropriate.

6.10.4 The mitigating features of the offending in connection with an Anti-Corruption Breach shall include the following:

- (a) Whether the Connected Person has a low degree of fault<sup>4</sup> in relation to the Anti-Corruption Breach;
- (b) The presence and timing of an acknowledgement of culpability/wrongdoing and/or remorse by the Connected Person;
- (c) A good disciplinary record and/or good character of the Connected Person;
- (d) The youth and level of experience of the Connected Person;
- (e) Where the Anti-Corruption Breach did not substantially damage (or have the potential to substantially damage) the commercial value and/or the public interest in the relevant Event(s);
- (f) Where the Anti-Corruption Breach did not affect (or have the potential to affect) the result of the relevant Event(s);
- (g) Where the Connected Person provides Substantial Assistance to World Rugby and/or a Union, a criminal authority or professional disciplinary body that results in World Rugby or Union discovering or establishing an Anti-Corruption Breach by another Connected Person or that results in a criminal or disciplinary body discovering or establishing a criminal offence or the breach of professional rules by another Connected Person or other third party;
- (h) Where the Connected Person has already suffered penalties under other laws and/or regulations for the same offence; and/or
- (i) Any other mitigating factor(s) that the Judicial Committee or Judicial Officer considers relevant and appropriate.

---

<sup>4</sup> Comment: For example, a low degree of fault may be inadvertent passing of Inside Information without Benefit.

6.10.5 For the avoidance of doubt:

- (a) Where a Connected Person is found guilty of committing two Anti-Corruption Breaches under these Anti-Corruption Regulations in relation to the same incident or set of facts and sanctioned separately, then any sanctions imposed should run concurrently (and not cumulatively);
- (b) Where a fine and/or costs award is imposed against a Connected Person, then such fine and/or costs award must be paid by the Connected Person (and not, unless World Rugby agrees, by any other third party, including a Union) within a reasonable time period specified by the Judicial Committee or Judicial Officer (or in the case of an appeal as applicable, by the Appeal Committee). Where the sanction imposed does not include a period of Suspension from the Game but does include a fine and/or costs award, pending the payment of such fine and/or costs the Connected Person may not participate in the Game on the same basis as if they were subject to Suspension;
- (c) Any Suspension imposed on the Connected Person shall commence on the date that the decision imposing the Suspension is issued unless indicated otherwise in the written decision;
- (d) Any Connected Person who has been Suspended may not, during the period of Suspension, fulfil any role set out within the definition of Connected Person in Regulation 6.2 including, for the avoidance of doubt, playing or training as part of any team or squad, participating or being involved in any capacity in the Game and/or participating in any function, event or activity (other than authorised anti-corruption education or rehabilitation programmes) that is authorised, organised, sanctioned, recognised or supported in any way by World Rugby, an Association, a Union or Rugby Body. Unions shall take all reasonable steps within their powers to give effect to this Regulation 6.10.5(d) where they have the jurisdiction to do so;
- (e) Connected Persons who are subject to a Suspension shall remain subject to the Anti-Corruption Regulations during that period in their former capacity (that is, Connected Person and, as applicable, Contract Player and/or Contract Player Support Personnel). If the Connected Person commits an Anti-Corruption Breach during a Suspension, this shall be treated as a separate Anti-Corruption Breach and separate proceedings will be brought pursuant to Regulation 6.7.5;
- (f) Once any period of Suspension has expired, the Connected Person will automatically become re-eligible to return to the Game provided that he has first: (a) completed a World Rugby-approved anti-corruption education programme to the reasonable satisfaction of World Rugby and is rehabilitated; (b) satisfied, in full, any fine and/or award of costs made against him by any Judicial Committee or Judicial Officer (or in the case of an appeal as applicable, Appeal



Committee); and (c) agreed to subject himself to such additional reasonable and proportionate monitoring procedures and requirements as the Anti-Corruption Officer may reasonably consider necessary given the nature and scope of the Anti-Corruption Breach committed.

6.10.6 Notwithstanding the discretion to impose a life Suspension in relation to an Anti-Corruption Breach of Regulation 6.3 and the right to appeal pursuant to Regulation 6.11, any Connected Person who has been held to have committed an Anti-Corruption Breach(es) in three (3) separate proceedings pursuant to these Anti-Corruption Regulations and/or those of a Union, Rugby Body or recognised sports body (per Regulation 6.14) shall automatically be Suspended for life.

### 6.11 Appeals

6.11.1 The decision of a Judicial Committee or Judicial Officer made under these Anti-Corruption Regulations may be challenged by World Rugby or a Connected Person or the Union of a Connected Person who is the subject of the decision (as applicable) to an Appeal Committee as set out in this Regulation 6.11.

6.11.2 Decisions being appealed shall remain in effect and binding pending resolution of the appeal.

6.11.3 The time limit for filing an appeal to World Rugby or Union (as applicable) shall be fourteen (14) days from the date of receipt of the written reasoned decision by the appealing party.

6.11.4 The general procedures relating to hearings before Appeal Committees contained in Regulation 18 Appendix 1 shall apply to any matter arising under these Anti-Corruption Regulations subject to any provisions to the contrary herein.

6.11.5 The notice of appeal shall be in writing signed by the Connected Person or party lodging the appeal and shall specify the following information (the '**Notice of Appeal**')

- (a) The name of the Appellant lodging the appeal;
- (b) The written decision appealed against, and the date and a copy thereof;
- (c) The date of receipt of the decision appealed against by the Appellant;
- (d) The specific grounds of appeal;
- (e) The appellant's request for relief;
- (f) Evidence of payment of any appeal deposit.

Except as provided, no specific form of a notice of appeal is required.

6.11.6 World Rugby shall require each Notice of Appeal to be accompanied by a deposit of an amount not exceeding £5,000 (pounds sterling). In the event of the deposit not being paid the appeal shall be deemed to have been abandoned. The Appeal Committee in any case shall have the power to extend the time for payment of the deposit. In the event of an appeal by World Rugby or a Union, no appeal deposit shall be payable.

6.11.7 On the lodgement of the appeal World Rugby shall notify the applicable parties and make available the full record of the proceedings of the Judicial Committee or Judicial Officer to the Appeal Committee.

## **6.12 World Rugby Assistance and Supervision**

6.12.1 Notwithstanding Regulation 6.7.9, a Union may request World Rugby to assume the conduct of an investigation and/or hearing under these Anti-Corruption Regulations (following a referral pursuant to Regulation 6.7.9) and/or its anti-corruption regulations where there is or appears to be an international element, where the Union does not have sufficient resources and/or expertise to continue with the investigation and/or manage the hearing and/or otherwise where appropriate. Where World Rugby agrees to the request the Union shall provide all assistance to World Rugby with respect to the conduct of the investigation and/or hearing as World Rugby shall require.

6.12.2 Notwithstanding Regulation 6.7.9 and Regulation 6.12.1, where World Rugby reasonably determines that there has been an abject failure by a Union to proceed with an investigation and/or a hearing referred to it under these Anti-Corruption Regulations and/or otherwise under its anti-corruption regulations and/or where a sanction arising from a hearing and/or appeal conducted by the Union pursuant to these Anti-Corruption Regulations and/or its anti-corruption regulations is manifestly inappropriate and/or erroneous in all of the circumstances, World Rugby may in the interests of the image of the Game assume the conduct of such investigation and/or remit a decision from a Union to be re-heard before a Judicial Officer, Judicial Committee or Appeal Committee as appropriate.

## **6.13 Confidentiality**

6.13.1 World Rugby and the Union concerned shall take reasonable steps to maintain confidentiality with respect to any action pursuant to these Anti-Corruption Regulations, save as required with respect to compliance with applicable laws and regulations and/or competent authorities and consultation with advisers, until such time as the decision of the Judicial Committee or Judicial Officer, if any, has been reached and the Connected Person the subject of that decision and his Union have been informed.

## **6.14 Recognition of Decisions**

6.14.1 Any decision of World Rugby or the decision of a Union and/or Tournament Organiser where such decision is recognised and accepted by World Rugby in connection with these Anti-Corruption Regulations and/or the anti-corruption regulations of a Union and/or Tournament Organiser, shall be

recognised automatically (without the need for further formality) by all Unions and Tournament Organisers which shall take all necessary action to render such decision (including without limitation any sanctions and/or penalties) effective (in compliance with any applicable laws).

- 6.14.2 Subject to the right of appeal, World Rugby shall respect any decision (including without limitation any sanctions and/or penalties) issued in compliance with the Olympic Movement Code on the Prevention of Manipulation of Competitions. In addition, World Rugby may as appropriate recognise other decisions imposed by public authorities and/or other sports in respect of corruption and betting-related matters whether specifically defined hereunder or otherwise, and may recognise and/or impose appropriate sports-based sanctions, including without limitation the sanctions provided for in these Anti-Corruption Regulations. For the avoidance of doubt there shall be no form or time limit applicable to the recognition of any decision by World Rugby pursuant to this Regulation 6.14. Where World Rugby recognises such a decision, the decision shall thereafter be recognised automatically (without the need for further formality) by all Unions and Tournament Organisers which shall take all necessary action to render such decision (including without limitation any sanctions and/or penalties) effective in relation to involvement in the Game (in compliance with any applicable laws).



---

**REGULATION 7. APPEARANCES, COMMUNICATIONS,  
ADVERTISING AND SPONSORSHIP**

- 7.1** A Person may not, without the prior written consent of his Union or Association (such consent to be at the discretion of the Union or Association), receive directly or indirectly any Material Benefit for appearing in, assisting with or communicating any advertisement, endorsement or promotion of any product, service or item which by virtue of content and/or presentation relates or refers wholly or partly to the Game, which relation or reference shall include, without limitation, the wearing, use or appearance with any rugby clothing, rugby articles or rugby related equipment of any nature whatsoever. For the purposes of this Regulation, Person shall mean a Player, trainer, referee, touch judge, coach, selector, medical officer who is currently involved in the Game, or in the organisation, administration or promotion of the Game.
- 7.2** The rights of a Person under this Regulation may be further limited or restricted by any agreement, understanding or contractual obligations between him and his Union, Association, Rugby Body or Club.
- 7.3** A Union, Association, Rugby Body or Club may accept sponsorship or any other financial assistance from any source including from a commercial firm or organisation, or an individual in his commercial capacity, and from which any commercial publicity accrues or is evident, provided it complies with the regulations of the Union or Association concerned and with these Regulations.
- 7.4** For Rugby World Cup qualifying and finals tournaments additional regulations in respect of, appearances, communications, advertising and sponsorship shall be promulgated.
- 7.5** No advertising shall be allowed or sponsorship may be accepted, by any Union, Association, Rugby Body, Club or Person and no Union or Association may approve advertising or sponsorship for any member, that is offensive or defamatory.
- 7.6** All relevant information regarding sponsorship or other financial assistance should be exchanged between the Unions concerned in an International Match not later than 12 weeks prior to the date of the said International Match so as to avoid conflict between sponsorship agreements entered into by the respective Unions. In the event that Unions have not resolved such conflict by mutual agreement 21 days prior to the International Match taking place, the matter shall be referred by either Union to the CEO, or his designee, who shall, as soon as reasonably practicable, adjudicate on the matter. The decision of the CEO, or his designee, shall be final and binding on the Unions concerned.



**REGULATION 8. ELIGIBILITY TO PLAY FOR NATIONAL REPRESENTATIVE TEAMS**

- 8.1** Subject to Regulation 8.2, a Player may only play for the senior fifteen-a-side National Representative Team, the next senior fifteen-a-side National Representative Team and the senior National Representative Sevens Team of the Union of the country in which:
- (a) he was born; or
  - (b) one parent or grandparent was born; or
  - (c) he has completed thirty six consecutive months of Residence immediately preceding the time of playing.
- 8.2** A Player who has played for the senior fifteen-a-side National Representative Team or the next senior fifteen-a-side National Representative Team or the senior National Representative Sevens Team of a Union is not eligible to play for the senior fifteen-a-side National Representative Team or the next senior fifteen-a-side National Representative Team or the senior National Representative Sevens Team of another Union.
- 8.3** For the purposes of this Regulation, a Player is deemed to have played for the senior fifteen-a-side National Representative Team or the next senior fifteen-a-side National Representative Team of a Union if:
- (a) He is selected for such team to play in an International Match against the senior fifteen-a-side National Representative Team or the next senior fifteen-a-side National Representative Team of another Union (or in a fifteen-a-side international Match against another Union's senior or next senior Touring Squad during a World Rugby approved International Tour) and is present at the Match played by that team either as a replacement, substitute or a playing member of that team and has, at the time of the Match, reached the age of majority; or
  - (b) He is selected to represent a Union's senior Touring Squad on an International Tour which includes an International Match or Matches approved by World Rugby and is present at any fifteen-a-side Match played on that International Tour either as a replacement, substitute or a playing member of a team selected from the Union's senior Touring Squad and has, at the time of the Match, reached the age of majority; or
  - (c) He is selected to represent a Union's next senior Touring Squad on a World Rugby approved International Tour and during that International Tour he is present at a Match against the senior fifteen-a-side National Representative Team or the next senior fifteen-a-side National Representative Team of another Union either as a replacement, substitute or playing member of a team selected from

the Union's next senior Touring Squad and has, at the time of the Match reached the age of majority.

- (d) He is selected to represent the Under 20s National Representative Team of a Union which has been pre-designated as that Union's next senior fifteen-a-side National Representative Team and the Player is part of the team which participates in an International Match as part of the World Rugby Junior World Championships, World Rugby Junior World Rugby Trophy or the Six Nations U20 Championship and is present at the Match played by that Team either as a replacement, substitute or playing member of that Team and has, at the time of the Match, reached the age of majority.

**8.4** For the purposes of this Regulation, a Player is deemed to have played for the senior National Representative Sevens Team of a Union if he is selected to represent a Union's senior National Representative Sevens Team in an International Match against the senior National Representative Sevens Team of another Union and is present at the Match played by that Team either as a replacement, substitute or playing member of that Team and has, at the time of the Match, reached the age of majority.

## **8.5 Responsibility, breach and penalties for a breach of Regulation 8**

### **8.5.1 Unions**

Regulation 8 is a strict liability offence and shall be construed in accordance with the principles of strict liability under English law. It is not, therefore, necessary that fault or intent on the part of a Union be shown in order for a breach of Regulation 8 to be established. Nor is lack of fault or intent on the part of a Union a defence to a breach of Regulation 8. For the avoidance of any doubt (and without limiting a Union's other obligations and responsibilities for the conduct, acts or omissions of its members and Persons under its jurisdiction pursuant to any other Regulation) Unions are responsible and accountable for the conduct of their Players and all Persons under its jurisdiction in relation to compliance with the provisions of Regulation 8 and any breach of Regulation 8 by such Player(s) or Person(s) shall be deemed to be a breach of Regulation 8 by the Union concerned. Each breach of Regulation 8 by a Union, howsoever arising, will result in a minimum fixed fine being imposed on the Union concerned. The minimum fixed fines for each breach of Regulation 8 are as follows:

- (a) For a Union that is represented on the Council £100,000 sterling;
- (b) For all other World Rugby Member Unions £25,000 sterling.

Based on the facts and circumstances of any breach of Regulation 8 the applicable minimum fixed fine as set out above may be increased. In addition, other penalties as set out in Regulation 18.6 may also be imposed on the Union concerned.



8.5.2 In exceptional circumstances, a Union in breach of Regulation 8 may make submissions to the relevant disciplinary body appointed under Regulation 18 to adjudicate on the case as to why the Union should not be subject to the applicable minimum fixed fine. For the avoidance of any doubt, however, the relevant disciplinary body shall only be entitled to reduce the applicable minimum fixed fine set out in this Regulation where the Union is able to provide clear and indisputable evidence that truly exceptional circumstances exist and that the Union concerned had taken all necessary steps to comply with Regulation 8.

### **Players**

8.5.3 Notwithstanding Regulations 8.5.1 and 8.5.2 above and without prejudice to any sanction imposed on a Union, Players may also be subject to sanction in accordance with Regulation 18 where they breach Regulation 8 in circumstances where they knew or ought reasonably to have known they were not eligible to play for the relevant Union at the time of participation.

8.6 To be eligible to participate in the Olympic Games, Olympic qualification events (together “Olympic Events”) or other events governed by the Olympic Charter all members of the senior National Representative Sevens Team(s) of a Union or the selected Olympic Sevens Team(s) of a National Olympic Committee shall comply with Regulation 8.1 and must be a national of the country of the National Olympic Committee which it is representing in such Olympic Events. Regulation 8.2 applies equally to all Players.

8.7 A Player who is a national of the country or Union for which he has been captured under Regulation 8.2 and who holds the nationality of another country or Union, may apply to participate in an Olympic Event to represent his new country or Union subject to the following conditions;

8.7.1 The Regulations Committee shall consider the application of a Player under this Regulation 8.7 which must be submitted with all relevant supporting documentation by the Union for whom the Player wishes to next represent in an Olympic Event (or a Union associated with the Olympic Sevens Team the Player wishes to represent). The application shall be pre-notified to the Player’s Union (namely the Union whose National Representative Team the Player represented);

8.7.2 The Player will be required to observe and demonstrate a stand down period of at least 3 years since the time the Player last represented their former Union and the time the Player first plays for the second Union or country, which must be in an Olympic Event. The Player may not represent the second Union in any other form of the Game until after they have participated in such Olympic Event.

(a) Solely in respect of the Rio Olympic Games 2016, a stand down period of at least 18 months will be permitted, between the time the Player last represented their former Union and the time the Player first plays for the second Union or country, which must be in an

Olympic Event in the Rio Olympic Games cycle, which the Player must observe and demonstrate.

- 8.8** Where the Player is not a national of the Union for which he has been captured under Regulation 8.2, and he meets the Olympic eligibility criteria (in Regulation 8.6 to 8.13) as determined by the Regulations Committee, he shall be eligible for selection to play for the Union / country of which he is a national, in an Olympic Event, subject to satisfying the applicable stand down period.
- 8.9** A Player who is eligible or captured for a Union that cannot participate in an Olympic Event because there is no National Olympic Committee solely for the territory of such Union, may, subject to the Olympic eligibility criteria (in Regulation 8.6 to 8.13), be eligible to play for the Olympic Sevens Team of a National Olympic Committee of which he is a national, provided that such team is not associated with any one single Union. In such circumstances the following provisions shall apply;
- 8.9.1** Where the Player has been captured under Regulation 8.2 for a Union he shall remain captured for such Union notwithstanding the Player's representation for the Olympic Sevens Team of a National Olympic Committee in an Olympic Event;
- 8.9.2** Where the Player has not previously been captured under Regulation 8.2 and he represents the Olympic Sevens Team of a National Olympic Committee in an Olympic Event he will be deemed to be captured for one of the underlying Unions which support the Olympic Sevens Team of the relevant National Olympic Committee, and the Player must elect which of those underlying Unions he shall be captured by for the purposes of Regulation 8.
- 8.10** A Player who has represented one Union or Olympic Team in an Olympic Event and who has changed his nationality or acquired a new nationality, may apply to participate in an Olympic Event to represent his new Union or country provided that at least three years have passed since the Player last represented his former Union or country and the approval of the International Olympic Committee, the relevant National Olympic Committee(s) and World Rugby is obtained. This period may be reduced or even cancelled with the agreement of the World Rugby and the National Olympic Committees concerned and by the IOC Executive Board, which takes into account the circumstances of each case.
- 8.11** A Player may not represent two different Unions or a Union and an Olympic Sevens Team(s) of a National Olympic Committee in the same Olympic Event(s).
- 8.12** Once the Player has represented the Union of which he is a national, in an Olympic Event, he shall thereafter be tied to that Union for all forms of the Game and in all events.
- 8.13** Players who participate in the Olympic Events accept and agree that any disputes relating to eligibility shall first be addressed pursuant to the rules

of such Olympic Events and the World Rugby Regulations and that all internal procedures (including applicable National Olympic Committee rules/procedures) and/or World Rugby procedures shall be exhausted first. Thereafter, recourse may be had in respect of Olympic Events only (and not in relation to eligibility matters to which Regulation 8.6 to 8.16 does not apply) to the Court of Arbitration for Sport (CAS) in accordance with the provision applicable before such court and which will resolve definitively the dispute in accordance with the code of sports related arbitration. World Rugby has the right to appear, attend and/or participate as a party in any appeal to CAS involving eligibility considerations for Olympic Events.

- 8.14** Any Union wishing to obtain clarification around the eligibility of a Player to represent it in the Olympic Games or Olympic Events may do so by referring the matter to the World Rugby Regulations Committee in accordance with Regulation 2 and Regulation 8.7.1 and 8.7.2.
- 8.15** The list of Olympic Events is set out in Schedule 2 and shall be updated for each Olympic cycle.
- 8.16** The provisions of Regulation 8.5 apply equally to any alleged breach of the Olympic eligibility provisions.

## EXPLANATORY GUIDELINES ON THE IMPLEMENTATION OF REGULATION 8

### ELIGIBILITY TO PLAY FOR NATIONAL REPRESENTATIVE TEAMS

Following its deliberations on the question of Player eligibility, the Working Party has produced these Explanatory Guidelines on the implementation of Regulation 8. These Explanatory Guidelines must be read in conjunction with the terms of Regulation 8.

#### 1. **What is the Rationale/Philosophy of Regulation 8?**

The rationale/philosophy of Regulation 8 is to ensure that Players selected to represent either the senior and next senior fifteen-a-side National Representative Teams of a Union or a Union's senior National Representative Sevens Team have a genuine, close, credible and established national link with the country of the Union for which they have been selected. Such a national link is essential to maintain the unique characteristics and culture of elite international sporting competition between Unions. The integrity of International Matches between Unions depends upon strict adherence to the eligibility criteria set out in the Regulations.

#### 2. **Who establishes the eligibility criteria in Rugby Union?**

World Rugby will continue to establish the criteria by reference to which a Player's eligibility to play for the senior or next senior fifteen-a-side National Representative Team of a Union or a Union's senior National Representative Sevens Team will be determined. Citizenship of a country and/or whether a Player holds a passport of a particular country are not, of themselves, determinative in identifying which Union a Player is eligible to represent. This will be determined solely in accordance with World Rugby's eligibility criteria. In relation to Olympic eligibility criteria see the Explanatory Guidelines on the Implementation of Regulation 8 – Olympic Eligibility.

#### 3. **What is the eligibility criteria in Rugby Union?**

The existing World Rugby eligibility criteria set out in Regulation 8.1 will be maintained. This is based on the following:

- (a) The country in which the Player was born; or
- (b) The country in which one parent or grandparent of the Player was born; or
- (c) The country in which the Player has completed thirty-six consecutive months of Residence immediately preceding the time of playing. Residence means the place or location in which a Player has his primary and permanent home and Resident shall be construed accordingly; and

- (d) For Olympic Event participation, the nationality of the Union / country the Player wishes to represent is also required.

**4. If a Player has dual eligibility, can he play for the senior or next senior fifteen-a-side National Representative Team or the senior National Representative Sevens Team of more than one Union?**

No, save for those Players that, before 1 January 2000, allowed a period of 36 consecutive months to elapse after they had played for another Union and who played for the second Union before 1 January 2000. The one Union only rule, introduced by World Rugby from 1st January 2000 (as set out in Regulation 8.2), will be maintained. A Player is only entitled to play Rugby Union for the senior or next senior fifteen-a-side National Representative Team or the senior National Representative Sevens Team of one Union. Accordingly, if a Player is deemed to have played for such a team, even if he is able to satisfy one or more of the eligibility criteria set out in Regulation 8.1, he will not be able to play for any other Union. Consistent with the overall rationale underlying the eligibility Regulations, the one Union only rule is designed to maintain the integrity of the international Game. Once a Player has committed himself to a particular Union, through participation in one of the Matches or Tours identified in Regulations 8.3 or 8.4, he is unable to change his “Rugby Nationality” which becomes fixed.

**5. When is a Player deemed to have played for the senior or next senior fifteen-a-side National Representative Team of a Union or a Union’s senior National Representative Sevens Team?**

As a result of the one Union only rule, in particular, it is essential that Players and Unions understand the situations in which Players will be deemed to have played for the senior fifteen-a-side National Representative Team or the next senior fifteen-a-side National Representative Team of a Union or a Union’s senior National Representative Sevens Team. These situations are set out in Regulations 8.3 and 8.4. Players and Unions shall, at all times, have regard to the full terms of Regulations 8.3 and 8.4, however, by way of a summary only, the situations set out below are covered:

**Fifteen-a-side**

- (a) Players who participate in International Matches for the senior National Representative Team or the next senior National Representative Team of a Union against the senior or next senior National Representative Team of another Union.
- (b) Players selected to represent a Union’s senior Touring Squad who participate in any Match played by members of that Union’s senior Touring Squad during an International Tour provided such International Tour includes an International Match(es) approved by World Rugby.

- (c) Players who participate in a Match for the senior or next senior National Representative Team of a Union against a team made up of Players from a Union's senior Touring Squad during an International Tour which includes International Match(es) approved by World Rugby.
- (d) Players, representing a Union's next senior Touring Squad who participate in a Match on an International Tour approved by World Rugby against the senior National Representative Team or the next senior National Representative Team or the next senior National Representative Team of another Union.
- (e) Players who play for the senior or next senior National Representative Team of a Union against a team selected from a Union's next senior Touring Squad when such Match is played on an International Tour approved by World Rugby.

### **Seven-a-side**

- (a) Players who play for a Union's senior National Representative Sevens team in an International Match against the senior National Representative Sevens team of another Union.

## **6. How do I know which team is a Union's next senior fifteen-a-side National Representative Team?**

- (a) There should be no uncertainty over which team constitutes a Union's next senior National Representative Team. Unions are required to notify World Rugby of the name of their nominated next senior National Representative Team. The team nominated remains the Union's next senior National Representative Team unless the Union notifies World Rugby of a change in this nomination. A Union is entitled to notify World Rugby no more than once per calendar year of a change to its next senior National Representative Team provided that in doing so it shall take account of any Matches such team may be scheduled to play and shall advise the Union of any senior or next senior National Representative Team it is scheduled to play reasonably in advance of such Match. The identity of a Union's next senior National Representative Team can be verified with the Union concerned and/or World Rugby.
- (b) Unions must ensure that all persons involved in an International Match (Players and team management including coaching staff) are made aware of the status of their team as the next senior National Representative Team and that of their opposing team where it is the senior or next senior National Representative Team of another Union and what that means from a capturing perspective under Regulation 8. Notwithstanding the Union's obligation to inform the Player and team management it shall be the sole responsibility of each Player to ensure that he is aware of the status of every Match in which he plays and the implications of playing in an International

Match involving the senior or next senior National Representative Teams of two Unions.

- (c) In addition to (a) and (b) above, Unions who designate their Under 20s National Representative Team as their next senior National Representative Team have a particular onus to clearly make the Team Players aware of the consequences of being captured for that Union at age grade level. Effective 1 July 2014, the Players on any such Team which participates in the World Rugby Junior World Championships, World Rugby Junior World Trophy or the Six Nations U20 Championship (where they are present at the Match played by that Team either as a replacement, substitute or playing member of that Team and has, at the time of the Match, reached the age of majority) will be captured. In this regard the status of the opposition teams in any Match in these named tournaments is not a factor to be considered.

**7. What is the age of majority?**

For the purposes of the Regulations (including, but not limited to Regulation 8), the age of majority is deemed to be acquired on a Player's 18th birthday.

**8. Does the eligibility criteria apply to all forms of Rugby?**

The eligibility criteria applies to the fifteen-a-side Game at senior and next senior National Representative level and in respect of a Union's senior National Representative Sevens Team.

**9. Does the eligibility criteria apply to all Unions in membership of World Rugby?**

Yes, all Unions in membership of World Rugby are obliged to comply with the eligibility Regulation

**10. How will the eligibility criteria be assessed?**

Ordinarily, the task of assessing whether a Player satisfies any of the eligibility criteria set out in Regulation 8.1 is straightforward. However, as a result of professionalism, greater mobility and societal family change this is not always the case. Difficult cases have arisen and may continue to emerge. The responses to the questions set out below are intended to provide further clarification as to how each eligibility criterion in Regulation 8.1 will be applied.

The questions and answers should be regarded as guidelines. They have been prepared on the basis of operational experience to date. It is not possible to anticipate all scenarios that may arise and a degree of flexibility in the application of the Regulations will be maintained. Moving forward, in the event that there is any uncertainty or the need for clarification in relation to the application of the eligibility criteria in particular circumstances, then the Regulations Committee may be asked by World Rugby to make a ruling on a Player's eligibility. In relation to any

such adjudication, the Regulations Committee will always have in mind the rationale behind Regulation 8. The aim of the Regulations Committee in each case where clarification may be required, is to establish whether, in all the circumstances, a Player has, by reference to the eligibility criteria in Regulation 8.1, been able to demonstrate a genuine, close and credible national link with the country that the Player wishes to represent. It is anticipated that over time a body of rulings by the Regulations Committee may develop which may, in turn, assist in providing further guidance to Unions in relation to eligibility matters.

**11. When should any uncertainty over a Player's eligibility be clarified?**

It is essential that eligibility issues are clarified before a Player represents the senior or next senior fifteen-a-side National Representative Team of a Union or a Union's senior National Representative Sevens Team. This is particularly important in light of the one Union only rule. Accordingly, if a Union has any doubt over a Player's eligibility status it must take all steps necessary to clarify the position before selecting the Player to play for its senior or next senior fifteen-a-side National Representative Team or its senior National Representative Sevens Team.

**12. What does place of birth mean?**

This should be the most straightforward criterion to apply. A Player's place of birth shall be the country within whose geographical borders he was born. However, difficult scenarios can arise even in relation to this criterion. For example, where a Player was born within the geographical borders of one country, but in a part of that country deemed by the law of the country concerned, to be the sovereign territory of another, or where a Player was born in a military hospital. In such circumstances the matter should be referred to the Regulations Committee for a ruling. The Regulations Committee would need to establish the legal position together with other relevant facts and circumstances. In exceptional circumstances it may be possible for a Player to demonstrate, to the satisfaction of the Regulations Committee, that he is eligible to play for the Union within whose sovereign territory he was born, even though that sovereign territory may be within the geographical borders of another country.

**13. What does Parent mean?**

The term "parent" in the Regulations is limited to either a blood parent or a parent that has formally adopted a Player in accordance with the applicable legal requirements of the country concerned. Unless a Player has been adopted in accordance with the formal, legal requirements of the country concerned, the application of this criterion will be based on a Player's blood parent. When a Player has been formally adopted in accordance with the applicable legal requirements of the country concerned, the birth place of the Player's blood parent will no longer be relevant for the purposes of establishing the Player's eligibility pursuant to Regulation 8.1(b). The relevant parent will be the parent that has formally and legally adopted the Player. However in such circumstances, the relevant grandparents for the purposes of establishing a Player's eligibility



pursuant to Regulation 8.1(b) will be the Player's blood grandparents. It is not possible under Regulation 8.1(b) to assume eligibility via non-blood grandparents even if a Player has been formally and legally adopted.

For the avoidance of any doubt, stepparents and fostering parents will not be considered to constitute a Player's parent for the purposes of Regulation 8.1(b).

**14. How is the Residence criteria satisfied?**

Regulation 8.1(c) requires a Player to complete 36 consecutive months of Residence immediately preceding the time of playing. Residence is defined as "the place or location in which the Player has his primary and permanent home" and Resident shall be construed accordingly. In essence, Regulation 8.1(c) constitutes a sporting naturalization procedure, based on a geographical/presence test. As in any naturalisation process, a number of factors will influence the determination of what constitutes a Player's permanent and primary home. Such factors include, but are not limited to, the actual time spent in a country and the purpose of any absences during the qualification period. By being Resident in a country for a period of 36 consecutive months immediately preceding the time of playing for a Union, a Player is deemed to acquire a credible, close and established national link with a country/Union that entitles him to participate in sporting competitions for that Union. Based on the overriding rationale of the eligibility Regulations, in cases where a Player's eligibility is uncertain the Regulations Committee will consider that Player's eligibility by reference to the particular facts and circumstances of his case to establish if the Residency test, in the context of the overall rationale of the eligibility Regulations, has been satisfied. The principles set out in responses to the questions below will act as guidelines to the Regulations Committee when it is asked to consider any cases pursuant to this criterion.

**15. Whose burden of proof?**

In all cases where a Player is seeking to establish eligibility by reference to the Residency criteria in Regulation 8.1(c) (and, indeed, in relation to Regulation (or 8.1(a) and (b)), the burden of proof is on the Player and the Union that he wishes to represent to prove that Player's eligibility. Under Regulation 8.1(c), the Player and his Union must be able to demonstrate that, during the relevant period, the country in which he claims he has been Resident was, genuinely, the country that the Player treated as his home and is clearly the country in which the Player has his primary and permanent home. If a Player has moved from one country to another, and is seeking to establish Residence in that new country, then he must also be able to demonstrate that he is clearly no longer Resident in the country in which he lived previously and that he no longer treats that country as his home. For the avoidance of any doubt, a Player cannot nominate a country as his home without demonstrating that he has satisfied the geographical commitment/presence test enshrined in Regulation 8.1(c). The geographical commitment/presence test will be vigorously upheld and

applied to avoid abuse of the Residency criteria. For example, a Player that acquired/leased property in a country and who nominated that property as his permanent and primary home (even though he may only be present at that property and in that Union on a short term/temporary basis) would not satisfy the Residency test.

**16. Will short breaks interrupt a period of Residence?**

Short breaks in Residence, for example, for holidays, attending family/friends in other countries who may be ill etc, are unlikely to change the place/location of a Player's primary and permanent home and are, therefore, unlikely to interrupt a Player's period of Residence. By way of a guideline, however, as a minimum requirement, it is likely that, save in exceptional circumstances, at least 10 months actual physical presence of the Player in the country concerned throughout any qualifying year of the Residency period, will be required to demonstrate that the country is the place where the Player has his primary and permanent home.

**17. Does the 36 month period of Residence have to immediately precede playing for a Union?**

Save in exceptional circumstances, the 36 months Residence will be expected to have been completed consecutively and be achieved immediately before the Player represents a Union. This is designed to create a contemporary national link with the country of the Union concerned. This factor will be particularly significant if a Player has moved to make a "new" country his Residence having been Resident in another country previously. In essence, in such circumstances, the Player, as well as demonstrating his commitment to a new country, must also be (and seen to be) relinquishing his ties with the country in which he lived previously. For the avoidance of any doubt, seeking to rely on short periods of Residence as a child in a particular country, combined with a short period of Residence in that same country prior to playing for a Union, is likely to create a link that would be too tenuous to satisfy the underlying intentions of establishing a contemporary, permanent, national link with a Union. However, each case will be assessed on its overall merits to establish if a Player is able to demonstrate a genuine, close, credible and established national link by reference to the amount of time the Player can demonstrate that he has treated the "new" country as his home and other relevant factors.

**18. What is the position of students?**

As far as students are concerned, particularly those that are not financially independent, being resident, as a full time student, in another country, is likely to be considered as a series of temporary absences from the parental home. It is anticipated that in the majority of cases involving students the parental home is likely to continue to constitute the student's permanent and primary home. Accordingly, attendance at college/university in such circumstances is unlikely to break a Player's consecutive period of Residence. However, as in all matters of eligibility, the overriding concern of the Regulations Committee in assessing any

such case will be to ensure that there remains a close, credible and established link with the country in which the Player claims to have retained his primary and permanent home. There could be circumstances in which a student living in another country may be deemed to have interrupted his Residency period.

**19. Who is responsible for compliance with the eligibility criteria?**

In accordance with Regulation 2.1.2, each Union is responsible for ensuring compliance with all Regulations Relating to the Game This includes, but is obviously not limited to, Regulation 8. Accordingly, it is the responsibility of each Union to ensure that all Players it selects are properly eligible within the provisions of Regulation 8 and, in the event of any uncertainty, to ensure that the position is clarified before the Player is selected. Unions must have in place all necessary procedures and internal controls to ensure compliance with the eligibility Regulations.

**20. What must Unions do to ensure (and demonstrate) compliance with the eligibility Regulations?**

Unions must ensure that before a Player is selected for the first time for its senior or next senior fifteen-a-side National Representative Team or its senior National Representative Sevens Team the Player completes the standard form declaration attached to these Explanatory Guidelines at Schedule 1. In addition, before selecting a Player, Unions must ensure that they obtain valid/authentic documentation and such other evidence that may be necessary to prove, definitively, a Player's eligibility to play for that Union. Each Union must notify World Rugby of the names of all Player's selected for its senior and next senior National Representative Team and its senior National Representative Sevens Team on an annual basis. World Rugby shall maintain a database of all such Players. If requested, by the Chairman, or his designee, Unions must supply copies of the completed declaration forms of a Player(s) together with supporting documentation relied on to demonstrate the Player's eligibility. On 1 December each year, each Union must certify to World Rugby that each Player selected to represent the senior or next senior fifteen-a-side National Representative Team of the Union or its National Representative Sevens Team during the past year has completed, in full, the declaration form and that each Player was eligible to represent the Union in accordance with the provisions of Regulation 8.

World Rugby may, through the Chairman, or his designee, of his own motion or on receipt of a complaint undertake an investigation into a Union's compliance with Regulation 8. Unions, Players and officials must provide assistance with any such investigation and disclose such information and documents deemed necessary by the Chairman, or his designee, for the purposes of that investigation.

**21. What are the consequences of a breach of the eligibility Regulations by a Union?**

Compliance with Regulation 8 is of fundamental importance in maintaining the integrity of international Rugby Union at senior National Representative level. Any breach of such a fundamental Regulation, howsoever arising, has a detrimental impact on the image and reputation of the sport. Unions must, therefore take all necessary steps to put in place comprehensive review/compliance procedures to ensure that a breach of the eligibility provision does not occur whether negligently or otherwise. Alleged breaches of Regulation 8 may be investigated and handled in accordance with Regulation 18 (Disciplinary and Judicial Matters). However, a breach of the eligibility Regulations constitutes a strict liability offence. This means that a failure by a Union to fulfill its obligations and to comply with the eligibility Regulations will be regarded as a serious breach of the Regulations, howsoever such breach may have occurred. As a reflection of the seriousness with which any breach of the eligibility Regulations will be treated by World Rugby, it has been agreed by Council to establish a minimum fixed penalty to be imposed on a Union that has breached Regulation 8. These minimum fixed penalties will appear in Regulation 8 and, for ease of reference, are also set out below.

**8.5 Responsibility, breach and penalties for a breach of Regulation 8**

**8.5.1 Unions**

*Regulation 8 is a strict liability offence and shall be construed in accordance with the principles of strict liability under English law. It is not, therefore, necessary that fault or intent on the part of a Union be shown in order for a breach of Regulation 8 to be established. Nor is lack of fault or intent on the part of a Union a defence to a breach of Regulation 8. For the avoidance of any doubt (and without limiting a Union's other obligations and responsibilities for the conduct, acts or omissions of its members and Persons under its jurisdiction pursuant to any other Regulation) Unions are responsible and accountable for the conduct of their Players and all Persons under its jurisdiction in relation to compliance with the provisions of Regulation 8 and any breach of Regulation 8 by such Player(s) or Person(s) shall be deemed to be a breach of Regulation 8 by the Union concerned. Each breach of Regulation 8 by a Union, howsoever arising, will result in a minimum fixed fine being imposed on the Union concerned. The minimum fixed fines for each breach of Regulation 8 by a Union are as follows:*

- (i) For a Union that is represented on the Council £100,000 sterling;*
- (ii) For all other World Rugby Member Unions £25,000 sterling.*

*Based on the facts and circumstances of any breach of Regulation 8 the applicable minimum fixed fine as set out above may be increased. In addition, other penalties as set out in Regulation 18.6 may also be imposed on the Union concerned.*

**22. What must Players do to ensure (and demonstrate) compliance with the eligibility Regulations?**

Players are required to act honestly in matters relating to their eligibility to represent a particular Union. This would include, without limitation, fully disclosing to the Union (and World Rugby upon request) any matters relevant to the Player's eligibility and providing all reasonable assistance to the Union (and World Rugby upon request) in order to establish the Player's eligibility at the first available opportunity.

**23. What are the consequences of a breach of the eligibility Regulations by a Player?**

A Player who knowingly (and/or with reasonable enquiry ought to have known) represents a Union where not eligible to do so commits a breach of Regulation 8. Alleged breaches of Regulation 8 will be investigated and handled in accordance with Regulation 18 (Disciplinary and Judicial Matters). Judicial Officers and Judicial Committees may impose sanctions pursuant to their powers taking into consideration, without limitation, the circumstances of the breach including the number of breaches and the level of any deception. This may result in a Player being reprimanded, fined, suspended and/or such other sanction the Judicial Officer or Judicial Committee thinks fit, in accordance with Regulation 18.6.

**24. For the Player to be liable for a breach must the Union also have been found liable?**

Yes, there must also be a finding that the Union concerned has played an ineligible Player. However such finding would not be affected in circumstances where there was any reduction or suspension of the ordinarily applicable sanction.

## **Explanatory Guidelines on the Implementation of Regulation 8 – Olympic Eligibility**

With the re-introduction of Rugby Sevens into the Olympic Games in Rio in 2016 there are certain rules which participants must adhere to for eligibility purposes. The Olympic Eligibility Regulations (8.6 to 8.16) have been introduced to accommodate the Olympic Charter Rules. To assist in the implementation of these Regulations, the following Guidelines have been developed to address the specifics around Olympic Sevens eligibility which differs from that of World Rugby eligibility requirements in that it is based solely upon a nationality consideration alone. The two sets of rules have been combined to achieve harmony between the objectives and underlying philosophy of Regulation 8 and the requirements of the Olympic Charter in the context of participation in Olympic Events. These Explanatory Guidelines must be read in conjunction with the terms of Regulation 8 and the Guidelines thereto.

### **1. Who is eligible to play Olympic Sevens?**

Any Player who meets the eligibility criteria in 8.1 and holds the nationality of the Union / country they wish to represent in the Olympic Games or Olympic Qualification process (known as the “Olympic Events”). The eligibility rules in the Olympic Charter together with the World Rugby eligibility rules must be complied with by Players who participate in Olympic Events.

### **2. Must a Player have the passport of the Union / country he represents in Olympic Sevens?**

The nationality of the Union / country the Player wishes to represent in Olympic Sevens is a requirement under the Olympic Charter and is therefore necessary for participation in Olympic Events. Nationality is ordinarily demonstrated by the Player holding the passport of the Union / county they wish to represent. All matters relating to the determination of the country which a Player may represent in the Olympic Games shall ultimately be resolved by the IOC Executive Board.

### **3. Who will decide on Olympic Sevens eligibility?**

Ordinarily, the assessment of whether a Player satisfies the eligibility criteria in Regulation 8.1 and 8.6 will be straightforward. However, in all cases where a Player who has been captured under Regulation 8.2 and who holds the nationality of another Union / country and wishes to participate in an Olympic Event(s) for the Union / country of which he is a national, the Player may apply to World Rugby to represent the National Representative Sevens Team of that Union (or the Olympic Sevens Team of an National Olympic Committee), and the case shall be determined in the first place by the World Rugby Regulations Committee. In the event there are other cases of uncertainty or there is the need for clarification a referral may be made to the World Rugby Regulations Committee.

#### **4. What is required to be submitted to the Regulations Committee?**

Applications should be submitted to World Rugby accompanied by all relevant supporting documents by the Union (or in applicable cases where there is no Union, the National Olympic Committee (“NOC”)) of the country the Player wishes to represent in an Olympic Event. The application shall be pre-notified to the Player’s Union (namely the Union who’s National Representative Team the Player has previously represented. The Player’s Union may make written submissions to the World Rugby Regulations Committee or may be invited to do so.

#### **5. Can a Player with dual nationality, or having World Rugby eligibility for one Union but the nationality of another, represent both Unions / countries in the same Olympic qualification process?**

No. A Player may only represent one Union / country in the Olympic Events. For example if a Player played for a Union in the Sevens World Series in the year it was designated as an Olympic Event the Player could not later in the same Sevens World Series play for another Union / country even in circumstances where he was deemed eligible by the Regulations Committee to play for the second Union / country of which he is a national. The principle of Regulation 8.2 applies equally to Olympic Events, such that if a Player, having represented one Union / country in an Olympic Event they may not represent another Union / country thereafter.

#### **6. Can a Player switch nationality?**

Nationality is a matter which is governed by nation states. If a Player does switch nationality the effect of this upon their Olympic eligibility would need to be considered taking into account Regulation 8.6 to 8.16 and the Olympic Charter Rules regarding eligibility which can be found at [www.olympic.org](http://www.olympic.org). However, a Player who has represented one Union / country in an Olympic Event(s) and who has changed their nationality or acquired a new nationality may participate in Olympic Events to represent their new Union / country provided that at least three (3) years have passed since the Player last represented their former Union / country and the approval of the International Olympic Committee, the relevant National Olympic Committee(s) and World Rugby is obtained.

#### **7. How will the Olympic eligibility criteria be assessed?**

In the early days of the Olympic participation the view has been taken by World Rugby that the Regulations Committee should assess all cases where a Player who has already been captured for a Union under the one Union only rule (Regulation 8.2) but wishes to subsequently play for another Union / country for which s/he holds nationality in an Olympic Event.

#### **8. Is there any stand-down period?**

Yes. The Player will be required to observe and demonstrate a stand down period of three (3) years between the time the Player last played for

his Union and the time the Player first represents the second Union, which must be in an Olympic Event. Played, shall mean when s/he played for the senior, next senior or senior sevens National Representative Team of that Union for which s/he is captured. The principles of Regulation 8.3 apply in any assessment of this provision.

**9. What does ‘first represents’ mean?**

It means the first occasion when the Player represents the second Union in a Match, Tournament or Series of Matches – which must be in an Olympic Event. The Player would not however, be permitted for example to participate in pre-season Matches or so-called ‘friendly’ matches or other Matches which are not Olympic Events representing the second Union. Training with the team of the second Union is permitted but the circumstances should not be such that it presents or implies to third parties that the Player is part of the National Representative Sevens Team or Olympic Sevens Team of the second Union / country.

**10. How will the stand-down period be assessed?**

The onus will be on the Player to demonstrate to the reasonable satisfaction of the Regulations Committee the last occasion upon which s/he played for their former Union and that they have not represented such Union in the three year period before they represent their new Union / country in an Olympic Event.

**11. Are these Olympic Guidelines to be read with the World Rugby Eligibility Guidelines?**

Yes, both sets of Guidelines should be read together.

**12. What is the position for Unions who do not have a single NOC to represent them?**

Member Unions of World Rugby are not necessarily recognised in their own right with equivalent NOC’s, for example the British Olympic Association (Team GB) is the NOC for Great Britain and therefore encapsulates the Unions of England, Scotland, Wales and Northern Ireland (represented by the all-Ireland body of the IRFU). In such case, Players from the underlying Unions would be eligible (where they comply with Regulation 8.1 and 8.6) to represent the Olympic Sevens Team of the NOC (if selected) in relevant Olympic Events.

**13. If a Player plays for a combined team in an Olympic Event does it affect his eligibility in relation to World Rugby?**

If a Player plays for a combined team of a country in an Olympic Event (e.g. Team GB) and he was previously **not** captured for a Union (under Regulation 8.2) then the Player will be deemed to be captured for one of the underlying Unions of the combined team of country he represented. So in the case of Team GB it would mean that the Player would then be free to play for one of England, Scotland, Wales and/or Ireland.



If a Player plays for a combined team of a country in an Olympic Event (e.g. Team GB) and he was previously **was** captured for a Union (under Regulation 8.2) then the Player remains captured for such Union and their participation in the combined team in the Olympic Event will not affect their status.

**14. Is there a right of appeal from the decision of the World Rugby Regulations**

Yes. An Olympic Eligibility appeals committee has been established under Regulation 2 to deal with any appeals of decisions by the World Rugby Regulations Committee.

**15 For the Olympic Games 2016 in Rio, do any special provisions apply?**

Rugby Sevens will enter the Olympic Games for the first time in 2016. The qualification process has been established and all persons eligible to participate must have qualified by 11 July 2016. In terms of eligibility, the three (3) year stand-down period applies. However, given the timing of the clarification of the qualification process and the constitutional review of the eligibility requirements for Olympic Events a shorter stand-down period in respect **only** of the Olympic Games 2016 shall apply. In this regard any Player who wishes to represent a Union / country for whom s/he holds the nationality and has previously been captured for another Union may do so provided the Player stands down from their current Union at least 18 months before representing the Second Union in an Olympic Event in the Rio Olympic Games cycle.

## SCHEDULE 1. EXPLANATORY NOTE

As from 1 January 2000 a player is only entitled to play Rugby Union for the Senior National Representative Team or the next Senior National Representative Team of one Union. This means that if a player is deemed to have played for the Senior National Representative Team or the next Senior National Representative Team of a Union that player will be unable to play for any other Union. This is the position even if that player is able to satisfy one or more of the eligibility criteria set out in Regulation 8.1. It is important that players and Unions understand the situations in which players will be deemed to have played for the Senior National Representative Team or the next Senior National Representative Team of a Union. These situations are set out in Regulation 8.3.

Regulation 8.3 is based on a “selection and participation” test for players who have reached the age of majority [18 or over]. Players and Unions must familiarize themselves with Regulation 8.3. Players should be made aware by Unions of what constitutes that Union's Senior National Representative Team, its next Senior National Representative Team, its Senior Touring Squad and its next Senior Touring Squad and the Matches that will result in a player being committed to that Unions. The following situations are covered by Regulation 8.3.

1. Players who participate in International Matches for the Senior National Representative Team or the next Senior National Representative Team of a Union against the Senior or next Senior National Representative Team of another Union.
2. Players selected to represent a Union's Senior Touring Squad who participate in any Match played by members of that Union's Senior Touring Squad during an International Tour provided such International Tour includes an International Match(es) approved by World Rugby.
3. Players who participate in a Match for the Senior or next Senior National Representative Team of a Union against a team made up of players from a Union's Senior Touring Squad during an International Tour which includes International Match(es) approved by World Rugby.
4. Players, representing a Union's next Senior Touring Squad who participate in a Match on an International Tour approved by World Rugby against the Senior National Representative Team or the next Senior National Representative Team of another Union.
5. Players who play for the Senior or next Senior National Representative Team of a Union against a team selected from a Union's next Senior Touring Squad when such Match is played on an International Tour approved by World Rugby.

**SCHEDULE 1.       DECLARATION OF ELIGIBILITY OF A PLAYER  
 TO PLAY FOR THE SENIOR FIFTEEN-A-SIDE  
 NATIONAL REPRESENTATIVE TEAM, THE NEXT  
 SENIOR FIFTEEN-A-SIDE NATIONAL  
 REPRESENTATIVE TEAM OR THE SENIOR  
 NATIONAL REPRESENTATIVE SEVENS TEAM  
 OF A UNION**

**DECLARATION OF PLAYER**

I, ..... (Name) of .....

..... (Address)

confirm that, I have read and understand the criteria for eligibility set out in Regulation 8 of the World Rugby Regulations Relating to the Game (World Rugby Regulations) and I

hereby declare that I am eligible to play for .....

Union because:

Tick applicable box(es)

- I was born in the country for which fifteen-a-side senior National Representative Team or the next senior fifteen-a-side National Representative Team, or the senior National Representative Sevens Team of the Union for which I intend to play; or
- One of my parents or grandparent was born in the country for which senior fifteen-a-side National Representative Team or the next senior fifteen-a-side National Representative Team or the senior National Representative Sevens Team of the Union for which I intend to play; or
- I have completed thirty-six consecutive months of Residence immediately preceding the time of playing in the country for which senior fifteen-a-side National Representative Team or the next senior fifteen-a-side National Representative Team or the senior National Representative Sevens Team of the Union for which I intend to play.

AND

- I have not played for the senior fifteen-a-side National Representative Team or the next senior fifteen-a-side National Representative Team or the senior National Representative Sevens Team of any other Union.<sup>1</sup>

<sup>1</sup> If a Player has played for another Union's senior fifteen-a-side National Representative Team or next senior fifteen-a-side National Representative Team or senior National Representative Sevens team, this must be stated on this declaration form. For the avoidance of doubt, Players would only be eligible to play for a second Union if they can demonstrate that they allowed 36 consecutive months to elapse before they played for a second Union and that they played for that second Union before 1 January 2000. Any such Players should submit in writing the circumstances of such participation on a separate sheet

I have attached to this declaration relevant documentation<sup>2</sup> to prove my eligibility to play for the senior fifteen-a-side National Representative Team or the next senior fifteen-a-side National Representative Team or the senior National Representative Sevens Team of ..... Union and I understand and accept that if I am found to have played for the senior fifteen-a-side National Representative Team or next senior fifteen-a-side National Representative Team or the senior National Representative Sevens Team of a Union without satisfying the eligibility criteria set out in Regulation 8 of the World Rugby Regulations, and/or to have provided inaccurate information in this declaration then I and the Union concerned will be subject to sanctions.

Player's signature: .....

Date: .....

**DECLARATION OF UNION**

I, ..... (Name) the .....

of ..... (Position and Union)

hereby declare that the ..... Union has made all such necessary enquiries in relation to the above Player's eligibility to play for the senior fifteen-a-side National Representative Team or the next senior fifteen-a-side National Representative Team or the senior Sevens National Representative Team of the Union. I further declare that the Union is satisfied that the information provided by the Player in his declaration is correct, that the documentation in support of the Player's declaration is valid and that the Player is eligible to play for the senior fifteen-a-side National Representative Team or the next senior fifteen-a-side National Representative Team or the senior National Representative Sevens Team

of ..... Union. I understand and accept that if a Player plays for the senior fifteen-a-side National Representative Team or the next senior fifteen-a-side National Representative Team Union or the senior National Representative Sevens Team without satisfying the eligibility criteria set out in Regulation 8 of the World Rugby Regulations and/or the Union has provided inaccurate information in this declaration then the Union will be subject to the fixed penalty sanctions set out in Regulation 8.

Signed: .....

Date: .....

<sup>2</sup> *Players ARE expected to provide valid copy birth certificates or other relevant formal documentation in support of their declaration. Players may be requested to provide additional documentation as appropriate in support of their eligibility to play for a senior National Representative Team or the next senior National Representative Team of a Union.*

---

**SCHEDULE 2. OLYMPIC EVENTS**

1. The Olympic Games 2016 – Rio de Janeiro
2. The Men's Olympic Events:
  - World Rugby Sevens World Series 2014/2015
  - Designated Regional Olympic Qualification Tournaments (ROQTs):
    - Africa (CAR) 2015 Regional Sevens Championships
    - Asia (ARFU) 2015 Regional Sevens Championships
    - Rugby Europe 2015 Regional Sevens Championships
    - North America and Caribbean (NACRA) 2015 Regional Sevens Championships
    - Oceania (FORU) 2015 Regional Sevens Championships
    - South America (CONSUR) 2015/16 Regional Sevens Championships
  - World Olympic Qualification Tournament (WOQT)
3. The Women's Olympic Events:
  - World Rugby Women's Sevens World Series 2014/2015
  - Designated Regional Olympic Qualification Tournaments (ROQTs):
    - Africa (CAR) 2015 Regional Sevens Championships
    - Asia (ARFU) 2015 Regional Sevens Championships
    - Rugby Europe 2015 Regional Sevens Championships
    - North America and Caribbean (NACRA) 2015 Regional Sevens Championships
    - Oceania (FORU) 2015 Regional Sevens Championships
    - South America (CONSUR) 2015/16 Regional Sevens Championships
  - World Olympic Qualification Tournament (WOQT)

Note: The dates and locations of the Olympic Events will be published on the World Rugby website at least 6 months in advance of the relevant event.



---

**REGULATION 9. AVAILABILITY OF PLAYERS****Preamble**

- A.** High quality international Rugby is in the best interests of the sport at all levels. It promotes the sport and encourages new participants and support for the sport around the world and at all levels. International Rugby is a major public interest and it is in the best interests of the public that the best teams and Players represent their Unions. The retention of high quality international Rugby benefits Players because it fulfils their aspirations to play at the highest level of the sport. The selection of the best Players for international Rugby also represents the fairest selection system as it is based on playing merit. Rugby Bodies and Clubs benefit if Players play international Rugby as it improves the quality and experience of Players, increases their value and enhances commercial returns in respect of merchandising, broadcast, sponsorship and gates thereby contributing to the interests of the Rugby Body or Club that Player represents. The development of the sport is enhanced and furthered as a result of the generation of funds from international Rugby for reinvestment in the sport.
- B.** A Union must therefore be able to select and have available the Players it requires for International Matches and to build and develop team strategies in National Squad sessions in order to ensure that the quality and integrity of international Rugby is maintained. The future development and extension of the sport at all levels and throughout the world would be threatened if a Union was not able to select and have available the Players it requires.
- C.** World Rugby and Unions recognise that the Right to Release for Matches should be exercised reasonably and with due regard to the proper interests of the welfare of Players and other relevant entities who may be affected. This Regulation 9 reflects this balance, accommodates the difference in arrangements and sport structure from Union to Union and respects the position of Rugby Bodies and Clubs whilst recognising the fundamental role that international Rugby plays in the development of the sport worldwide. The Regulation has also been prepared on the basis that in light of the nature and physicality of the Game Players should have appropriate rest, recuperation and recovery opportunities so that when they participate in the Game they are able to do so at their best.
- D.** This Regulation 9 has been prepared on the basis of the current/projected World Rugby schedule of International Matches, International Tours and International Tournaments and the periods during which such International Matches, International Tours and International Tournaments shall take place. For the avoidance of doubt, this Regulation 9 does not in any way limit the effect and/or application of World Rugby Regulation 16.
- E. Spirit of implementation**
- In the best interests of the sport at all levels Regulation 9 must be implemented by all stakeholders properly and in good faith. Compliance

with not only the letter of the Regulation, but also its spirit is integral to achieving its objectives in the best interests of the sport. The implementation of the Regulation necessarily requires communication and consultation between different stakeholders particularly in regard to Player management and welfare considerations which should be addressed within the spirit of the Regulation. Areas where this may be particularly significant include, but are not limited to, medical issues, rehabilitation into participation and resumption of duty. In considering any implementation and/or enforcement scenarios World Rugby will seek to ensure that full and proper regard is had to the overriding philosophy and spirit of the Regulation in assessing the conduct of the parties concerned.

### **Right to Release**

- 9.1** A Union must, in accordance with the provisions of this Regulation 9, have the right to a Player's availability for selection and appearances for a National Representative Team or National Squad of that Union, including a reasonable preparation period immediately prior to Matches, (the Right to Release for Matches) and for Squad training sessions and/or other team building activities, excluding commercial activities, (the Right to Release for Squad Sessions).
- 9.2** A Union, Association, Rugby Body or Club is obliged to release a Player to the Union for which the Player is eligible when selected by such Union for a National Representative Team or National Squad in accordance with the provisions of this Regulation 9.
- 9.3** No Union, Association, Rugby Body or Club whether by contract, conduct or otherwise may inhibit, prevent, discourage, disincentivise or render unavailable any Player from selection, attendance and appearance in a National Representative Team or National Squad session when such request for selection, attendance and appearance is made in accordance with the provisions of this Regulation 9. Any agreement and/or arrangement between a Player and a Rugby Body or Club or between a Union or an Association and a Rugby Body or Club (and/or any proposal made and/or attempted to be made howsoever communicated) which is contrary to this Regulation 9.3 is prohibited, including, but not limited to any agreement and/or arrangement and/or proposal pursuant to which a Player is (or would be) unable to exercise the right to play for a Union.
- 9.4** Subject to Regulation 9.18, no Union, Association, Rugby Body or Club may require any payment or other benefit from or impose conditions relating to a Player's participation in a National Representative Team and/or attendance at a National Squad session of his Union when such participation and/or attendance has been requested in accordance with the provisions of this Regulation 9.

### **When the Right to Release applies**

- 9.5** The Right to Release for Matches shall apply to Designated Release Events, Global Release Periods, Hemisphere Release Periods and from June 1, 2012 to the Four Nations Release Period.



## 9.6 Designated Release Events

The Right to Release for Matches applies to the Designated Release Events set out below whenever such Designated Release Events are held. All Players selected to participate in Designated Release Events shall be released.

(a) Union Designated Release Events:

- (i) The quadrennial Rugby World Cup Tournament and qualification Matches.
- (ii) The quadrennial Rugby World Cup Sevens event.
- (iii) An Olympic Sevens Rugby event and qualification Matches.

(b) Combined Teams Designated Release Events:

- (i) The quadrennial British and Irish Lions Tour is a Designated Event and all Players selected to participate shall be released. The Release Period shall ordinarily commence on 1 June and ordinarily conclude on the 2nd weekend of July in the relevant year.
- (ii) The quadrennial Tour of the Combined Team of the Pacific Islands Unions (Fiji, Samoa and Tonga) is a Designated Event and all Players selected to participate shall be released. The Tour will take place in the November window in the relevant year.

## 9.7 Global Release Periods

There are two Global Release Periods.

(a) The June window

The Right to Release for Matches shall apply to each of the senior National Representative Team, the next senior National Representative Team and the Under 20 National Representative Team of a Union in respect of all International Matches, International Tours and International Tournaments played over a period of three weekends in June each year, save in a Rugby World Cup year, during which year the June window shall not operate in respect of Unions that qualified for the Rugby World Cup. Unless Council approves otherwise the three weekends in June shall be the second, third and fourth weekends.

(b) The November window

The Right to Release for Matches shall apply to each of the senior National Representative Team, the next senior National Representative Team and the Under 20 National Representative Team of a Union in respect of all International Matches, International Tours and International Tournaments played over a period of three

weekends in November each year, save in a Rugby World Cup year, during which year the November window shall not operate in respect of Unions that qualified for the Rugby World Cup. Unless Council approves otherwise the three weekends in November shall be the second, third and fourth weekends.

## **9.8 Hemisphere Release Periods and Tournament Release Period**

There are two Hemisphere Release Periods.

### **(a) Northern Hemisphere Release Period**

- (i) The Right to Release for Matches shall apply to Players who are eligible pursuant to Regulation 8 to represent the senior, the next senior National Representative Team or the Under 20 National Representative Team of a Northern Hemisphere Union in a Northern Hemisphere International Match, International Tour or International Tournament during the Northern Hemisphere Release Period.
- (ii) The Northern Hemisphere Release Period shall operate each year. It shall run from the first weekend of February each year and conclude on the third weekend of March. Players shall be released prior to the Northern Hemisphere Release Period in accordance with the provisions of Regulation 9.9.
- (iii) Subject to the provisions of Regulation 9.32 and Regulation 9.33, during the Northern Hemisphere Release Period Unions may only exercise the Right to Release pursuant to this Regulation 9 for five weeks out of the seven week period. The five weeks shall be the same weeks for each of the senior National Representative Team, the next senior National Representative Team and the Under 20 National Representative Team.
- (iv) Unless Council approves otherwise for the purposes of this Regulation 9, Northern Hemisphere Union shall mean the Unions listed in Appendix 1, Part A and Northern Hemisphere International Match(es), International Tour or International Tournament shall mean those Matches, Tours or Tournaments listed in Appendix 1, Part B.

### **(b) Southern Hemisphere Release Period**

- (i) The Right to Release for Matches shall apply to Players who are eligible pursuant to Regulation 8 to represent the senior, the next senior National Representative Team or the Under 20 National Representative Team of a Southern Hemisphere Union in a Southern Hemisphere International Match, International Tour or International Tournament during the Southern Hemisphere Release Period.

- (ii) Unless Council approves otherwise the Southern Hemisphere Release Period shall operate each year. It shall commence on or around July 1 and shall conclude on or around August 31. Players shall be released prior to the Southern Hemisphere Release Period in accordance with the provisions of Regulation 9.9.
- (iii) Subject to the provisions of Regulation 9.32 during the Southern Hemisphere Release Period Unions may only exercise the Right to Release pursuant to this Regulation 9 for six weeks out of the nine week period. The six weeks shall be the same weeks for each of the senior National Representative Team, the next senior National Representative Team and the Under 20 National Representative Team.
- (iv) Unless Council approves otherwise for the purposes of this Regulation 9, Southern Hemisphere Union shall mean the Unions listed in Appendix 2, Part A and Southern Hemisphere International Match(es), International Tour or International Tournament shall mean those Matches, Tours or Tournaments listed in Appendix 2, Part B.

Effective from 1 June 2012 a Tournament Release Period shall be introduced to be known as the Four Nations Release Period.

### (c) Four Nations Release Period

- (i) The Right to Release for Matches shall apply to Players who are eligible pursuant to Regulation 8 to represent the senior, the next senior National Representative Team or the Under 20 National Representative Team of a Four Nations Union in the Four Nations International Tournament during the Four Nations Release Period.
- (ii) Unless Council approves otherwise the Four Nations Release Period shall operate each year for an eight week period. It shall commence on or around the third weekend in August and shall conclude on or around the first weekend in October each year. Players shall be released prior to the Four Nations Release Period in accordance with the provisions of Regulation 9.9.
- (iii) Subject to the provisions of Regulation 9.32 and Regulation 9.33 during the Four Nations Release Period Unions may only exercise the Right to Release pursuant to this Regulation 9 for six weeks out of the eight week period. The six weeks shall be the same weeks for each of the senior National Representative Team, the next senior National Representative Team and the Under 20 National Representative Team.
- (iv) Unless Council approves otherwise for the purposes of this Regulation 9, Four Nations Union shall mean the Unions listed in Appendix 2, Part B.

### **Period of International duty for Matches**

**9.9** In each case of release a Union shall be entitled to exercise its Right to Release for Matches so that Players are assembled at a location determined by the Union selecting the Player and available to train at least five clear days prior to the commencement of the International Match, International Tour or International Tournament. If an International Tournament is not played on consecutive weekends then the five clear day period shall commence five days before each Match in the Tournament.

**9.10** For the quadrennial Rugby World Cup a Union shall be entitled to exercise its Right of Release for the Tournament so that Players are assembled at a location determined by the Union selecting the Player and available to train and/or play in warm-up Matches at least 35 clear days prior to the commencement of the opening Match of the Rugby World Cup Tournament.

### **Limitation on number of Matches for which the Right to Release can be exercised**

**9.11** Subject to Regulation 9.12 and Regulation 9.33, no Northern Hemisphere Union shall exercise the Right to Release for Matches on more than 11 occasions in a calendar year for each of its senior National Representative Team, next senior National Representative Team and the Under 20 National Representative Team. Subject to Regulation 9.12, no Southern Hemisphere Union shall exercise the Right to Release for Matches on more than 12 occasions in a calendar year for each of its senior National Representative Team, next senior National Representative Team and the Under 20 National Representative Team. Effective from June 1, 2012 and subject to Regulation 9.12 and Regulation 9.33, no Four Nations Union shall exercise the Right to Release for Matches on more than 12 occasions in a calendar year for each of its senior National Representative Team, next senior National Representative Team and the Under 20 National Representative Team.

(a) For Northern Hemisphere Unions these 11 occasions will be taken as follows:

- (i) 3 Matches in the June Global Release Period.
- (ii) 3 Matches in the November Global Release Period.
- (iii) 5 Matches during the Northern Hemisphere Release Period.

The 11 occasions in respect of which the Right to Release may be exercised shall be the same for each of the senior National Representative Team, next senior National Representative Team and the Under 20 National Representative Team.

(b) For Southern Hemisphere Unions these 12 occasions will be taken as follows:

- (i) 3 Matches in the June Global Release Period.
- (ii) 3 Matches in the November Global Release Period.
- (iii) 6 Matches during the Southern Hemisphere Release Period.

The 12 occasions in respect of which the Right to Release may be exercised shall be the same for each of the senior National Representative Team, next senior National Representative Team and the Under 20 National Representative Team.

- (c) Effective June 1, 2012 for Four Nations Hemisphere Unions these 12 occasions will be taken as follows:
  - (i) 3 Matches in the June Global Release Period.
  - (ii) 3 Matches in the November Global Release Period.
  - (iii) 6 Matches during the Four Nations Release Period.

The 12 occasions in respect of which the Right to Release may be exercised shall be the same for each of the senior National Representative Team, next senior National Representative Team and the Under 20 National Representative Team.

**9.12** The limitation on the exercise of the Right to Release for Matches in Regulation 9.11 above:

- (a) does not include Designated Release Events for which Players selected by a Union shall be released in any event.
- (b) may be extended via agreement pursuant to Regulation 9.32; and
- (c) effective June 1, 2012 is subject to the Cross Hemisphere Player Release period specified in Regulation 9.33.

**Limitation on the number of Squad sessions to which the Right to Release applies**

**9.13** The Right to Release for Squad sessions pursuant to this Regulation 9 will apply to three Squad sessions for up to 30 Senior National Representative Team Players each calendar year each of a maximum of three consecutive days (excluding travel). Such periods shall be in addition to the release provisions for International Matches, International Tours and International Tournaments. Such sessions shall be taken as set out below subject to the three consecutive day periods not preventing a Player(s) from participating in a Match for his Rugby Body or Club:

- (a) For all Unions, Monday to Wednesday of the week preceding the assembly period for the November window.
- (b) For Northern Hemisphere Unions, Monday to Wednesday of the week preceding the assembly period for the Northern Hemisphere Release Period.

- (c) For Southern Hemisphere Unions, Monday to Wednesday of the week preceding the assembly period for the Southern Hemisphere Release Period.
- (d) The third squad session may be taken from a Monday to Wednesday at the discretion of the Unions provided that the Union in which the Player is Registered is notified of the dates for the third Squad session prior to the commencement of the relevant season.

#### **Limitation on Squad sizes**

- 9.14** The Right to Release for Matches in respect of International Matches and International Tournaments (excluding the Rugby World Cup Tournament and any International Tours) and the Right to Release for Squad sessions, pursuant to this Regulation 9, shall be limited to a maximum of 30 Players for each National Representative Team or National Squad (as the case may be).
- 9.15** For International Matches (whether such Matches form part of an International Tournament or otherwise (but excluding the Rugby World Cup Tournament and any International Tours)) if a Player is not included in either the 26 or the 22 Players selected in accordance with Regulation 9.16 below then, if such Player at the time of non-selection is located in the same Regional Association of the Rugby Body or Club for whom he plays, he shall return to that Rugby Body or Club, subject always to the provisions of Regulation 9.24.
- 9.16** Prior to an International Match, the following shall apply:
- (a) Unions shall reduce their Squad size to 26 no later than 96 hours prior to the kick off of an International Match;
  - (b) 72 hours before the kick off of an International Match Unions shall announce and exchange a list of the 15 Players who will start the Match and up to 7 replacements/substitutes.

#### **Insurance**

- 9.17** The relevant obligations relating to a Union's insurance for Players where a Union exercises its Right to Release are set out in Appendix 3 to this Regulation 9.
- 9.18** For the purposes of this Regulation 9, while a Player is on International Duty (as defined in Appendix 3) it is a condition of the Right to Release that the Union requesting the Player's release under this Regulation 9 shall have the financial arrangements or insurance in place which meet the requirements set out in Appendix 3. A Union selecting a Player pursuant to this Regulation 9 shall, if requested to do so by any Player, Primary Employer (as defined in Appendix 3) or any other party having demonstrated to the satisfaction of World Rugby that it has a valid interest provide a certificate or other satisfactory evidence of compliance with the financial arrangements or insurance cover set out in Appendix 3. In the event that a Union does not satisfy the requirements of Regulation 9.17,

9.18 and Appendix 3 World Rugby may take such action as it considers appropriate.

#### **Cost of Travel, Accommodation and Food**

- 9.19** The Union calling for the release of a Player shall be responsible for the costs of travel incurred by the Player as a result of the release request and relevant accommodation and food whilst the Player is on International Duty when arranged by such Union.

#### **Resumption of duty with Rugby Body or Club**

- 9.20** A Player who has been in attendance with a Union for an International Match, International Tour or International Tournament shall be released back to his Rugby Body or Club as soon as reasonably practicable and in any event no later than 24 hours after the conclusion of the International Match, International Tour or International Tournament. Players are responsible for returning to their Rugby Bodies or Clubs within 36 hours of the conclusion of the International Match, International Tour or International Tournament when it has taken place in the same Regional Association in which he is Registered and within 60 hours where such International Match, International Tour or International Tournament has taken place outside of the Regional Association in which he is Registered. Unions shall do their utmost to ensure that the Player resumes duty with his Rugby Body or Club in accordance with these timeframes but it is the Player's responsibility to ensure that he returns within the applicable timeframes.
- 9.21** A Player who has been in attendance with a Union for a Squad Session shall be released back to his Rugby Body or Club as soon as reasonably practicable after the conclusion of the Squad Session. Players are responsible for returning to their Rugby Bodies or Clubs within 24 hours of the conclusion of the Squad Session when it has taken place in the same Regional Association in which he is Registered and within 36 hours where such Squad Session has taken place outside of the Regional Association in which he is Registered. Unions shall do their utmost to ensure that the Player resumes duty with his Rugby Body or Club in accordance with these timeframes but it is the Player's responsibility to ensure that he returns within the applicable timeframes.
- 9.22** If a Union repeatedly breaches the Resumption of Duty provisions in Regulations 9.20 and 9.21 then the Union concerned may be subject to sanctions. Such sanctions may include, but shall not be limited to, fines, reduction in Release entitlements and/or prohibitions on calling up Players.

#### **Notification of the exercise of the Right to Release**

- 9.23** A Union wishing to exercise its Right to Release for an International Match, International Tour or International Tournament or the right to release for a National Squad Session, must notify (in the case of a Player in the Union's own territory), the Player and his Rugby Body or Club and

(in the case of a Player not Registered in the notifying Union's territory), the Player, his Rugby Body or Club and the Union in whose jurisdiction the Player is Registered. Such notification should be delivered in writing at least 14 days before the date the Player must join the National Representative Team or attend a National Squad Session and should include details of the travel schedule and Release Period.

**9.24** In the event of a Union having to exercise its Right of Release for Matches or the Right to Release for Squad sessions in relation to a replacement Player due to an injury or other unforeseen withdrawal of another Player named in the original squad, the 14-day period shall not apply, but notice should be given by the Union concerned to the relevant parties as soon as reasonably practicable.

**9.25** If a Union has grounds to believe that a Player will not be released then a Union should notify the Secretary and/or CEO of the Union with which the Player is Registered as soon as possible and request that the Union take all necessary actions to ensure that the Player is released in accordance with the provisions of this Regulation 9.

#### **Assistance between Unions and from World Rugby**

**9.26** A Union which requests World Rugby's assistance to obtain the release of a Player playing in the territory of another Union may only do so in circumstances where:

- (a) The Union with which the Player is Registered has been asked to intervene and has refused to intervene or has intervened without success.
- (b) The relevant papers have been submitted to the CEO at least 48 hours before the assembly date.

Provided that where because of circumstances outside of the control of the Union seeking the release of the Player the 48 hour deadline is not met World Rugby may still provide assistance in securing the release of the Player.

#### **Non-release due to injury**

**9.27** A Player who is not released notwithstanding the exercise of the Right to Release for Matches or the Right to Release for Squad Sessions due to injury or illness, shall, if the Union that has sought the release of the Player so elects, agree to undergo a medical examination by a doctor of that Union's choice. During such examination, Players should disclose conditions which would or might impair their performance. A Player shall be entitled to request that such examination take place in the territory of the Union within which he is Registered.

**9.28** In circumstances where a Player may not be released due to injury or illness the doctor of the Union requesting the Player's release, or his nominee, and the doctor of the Player's Rugby Body or Club shall consult on the nature and extent of the injury or illness and seek to agree whether



the Player is fit to participate in any part of the relevant International Match(es), International Tour, International Tournament or Squad session concerned.

- (a) If the Union doctor, or his nominee, and the doctor of the Player's Rugby Body or Club agree that the Player is fit to respond affirmatively to the Release Request then the Player will be released.
- (b) If the Union doctor, or his nominee, and the doctor of the Player's Rugby Body or Club agree that the Player's injury and/or illness is such that he cannot respond affirmatively to the Release request then the Player shall not be entitled to play for a Rugby Body or Club for the period for which he has been or should have been in attendance with the National Representative Team or National Squad save that if a Player becomes fit to play during the course of a Designated Event, he is permitted to play for his Rugby Body or Club unless the Union wishes and is able pursuant to any rules governing the Designated Event, to add the Player to its Squad for that Designated Event.
- (c) If having attempted to achieve a consensus on the nature and extent of the injury or illness and the Player's fitness there remains disagreement between the Union doctor, or his nominee, and the Player's Rugby Body or Club doctor over the Player's fitness to participate and respond affirmatively to the release request, then in circumstances where it is the Union doctor, or his nominee, that considers the Player is fit to participate and respond affirmatively to the release request then, unless the Player's Union agrees otherwise in writing, such Player shall not play for any Rugby Body or Club during for the period for which he has been or should have been in attendance with the National Representative Team or National Squad, plus an additional 10 days thereafter.

#### **Non-release due to retirement**

**9.29** If a Union having exercised its rights pursuant to this Regulation is informed that a Player is not so released and/or is unwilling to participate on the grounds that they have retired from International Rugby then the Player shall be required to confirm his retirement in writing to his Union and sign a declaration. Such declaration will include an affirmation that the Player fully understands the consequences of his decision to retire and that the decision has been made on a voluntary basis and in accordance with the provisions of this Regulation 9. A declaration will also be required from the Player's Rugby Body or Club confirming that it has acted in accordance with the provisions of Regulation 9 in connection with the Player's decision to retire from the International Game.

**9.30** If a Player does retire in accordance with the provisions of Regulation 9.29 above, the Player shall not be entitled to play for that Union for a period of 12 months from the date of written confirmation of retirement

from the International Game being received by the Union save with the prior written approval of both the Player's Union and World Rugby.

### **Ineligibility to play consequent upon non-release**

- 9.31** If a Player is not released to attend and/or participate in a National Representative Team and/or National Squad Session contrary to the provisions of Regulation 9.3 then he shall not be entitled to play for any Rugby Body or Club for the period for which he has been or should have been in attendance with the National Representative Team or National Squad and an additional 10 days thereafter, unless the Player's Union agrees otherwise in writing. Such agreement shall be granted in the absence of evidence of a breach of Regulation 9.3. For the avoidance of doubt, additional sanctions may also be imposed in accordance with Regulations 9.34 to 9.37.

### **Extension by agreement**

- 9.32** This Regulation 9 sets out the minimum mandatory regulatory framework for the Game in relation to Player availability. However, a Union may by agreement enter into arrangements beyond the terms of this Regulation 9 for example in relation to the number of International Matches to be played, Squad sizes and other limitations in the Regulation. Such agreements may for example take the form of collective arrangements within a Union's territory (where the Union has primacy of contract in relation to its Players or otherwise), or be agreed by Unions with other Rugby Bodies or Clubs outside of that Union's jurisdiction. For the avoidance of doubt in circumstances where a Union does not have primacy of contract over a Player the application of Regulation 9 may not be narrowed by agreement or otherwise.

- 9.33** Cross Hemisphere Player Release [Effective June 1, 2012]

- (a) Where the Right to Release for Matches is exercised for Players pursuant to the Northern Hemisphere Release Period and such Players are contracted to Rugby Bodies or Clubs in the southern hemisphere then the exercise of the Right to Release pursuant to this Regulation 9 may be exercised for seven weeks out of the seven week period.
- (b) Where the Right to Release for Matches is exercised for Players pursuant to the Four Nations Release Period and such Players are contracted to Rugby Bodies or Clubs in the northern hemisphere then the exercise of the Right to Release pursuant to this Regulation 9 may be exercised for eight weeks out of the eight week period.

### **Sanctions for non-compliance**

- 9.34** A Rugby Body or Club that refuses to allow a Player to be released in accordance with this Regulation 9 and/or otherwise breaches its provisions (including but not limited to any delayed release which impacts on the Player's participation in, or his Union's preparation for the relevant International Match or Squad session) renders itself liable to sanctions by

the Union having jurisdiction to discipline such Rugby Body or Club. The applicable sanctions shall include, but not be limited to:

- (a) Termination or suspension of membership of the Union and/or withdrawal of other benefits of membership of the Union.
- (b) A financial penalty.
- (c) Deduction of league points.
- (d) Relegation or exclusion or disqualification from any competition.
- (e) Such other sanction as may be considered appropriate.
- (f) Any combination of the sanctions set out in (a) to (e) above.

Unions that take disciplinary action against Rugby Bodies or Clubs for non-compliance with Regulation 9 shall provide the CEO of World Rugby with a full report of all hearings including (without limitation) the written decision of the hearing body(ies) (incorporating the reasoning behind the findings and decisions). This information shall be provided within 72 hours of the final decision having been made.

**9.35** A Union or Association that fails to apply Regulation 9 properly and in good faith or whose member Rugby Bodies or Clubs fail to comply with Regulation 9 renders itself liable to sanctions by World Rugby pursuant to Regulation 18.

**9.36** World Rugby shall be entitled to initiate an investigation(s) of its own motion and/or on request into the implementation (or non-implementation) of Regulation 9, potential and/or alleged non-compliance by Unions, Associations, Rugby Bodies and/or Clubs or any other issues related to Regulation 9. Unions, Associations, Rugby Bodies and/or Clubs shall assist in any such investigation and make available information and/or documentation requested as part of such investigation. Unions shall procure compliance by their constituents, Rugby Bodies and Clubs with any investigations initiated by World Rugby and ensure that disclosure of relevant documentation can be secured. World Rugby may during or at the conclusion of any investigation refer a matter to the Union(s) concerned for further action and/or take such other steps as it considers appropriate in the circumstances.

**9.37** In the event of any alleged breach of Regulation 9 in connection with the British and Irish Lions and/or Combined Team of the Pacific Islands Unions, for the purposes of this Regulation 9 and/or Regulation 18 the relevant party in connection with any action and/or breach of Regulations and/or investigations shall be the Union within which the breach is alleged to have occurred, or that Union which otherwise has jurisdiction. Where the CEO, or his designee, considers it necessary, including without limitation where a dispute arises over which Union is the relevant party for dealing with an alleged breach of Regulation 9, the CEO or his designee may determine which Union shall deal with the alleged breach of Regulation 9.

### **Player availability in circumstances of dual eligibility**

**9.38** When a Union enters into a written agreement with a Player that contemplates the Player representing that Union at senior or next Senior Fifteen-A-Side National Representative Team level (whether at fifteen-a-side or seven-a-side Rugby), the Union may seek the Player's written agreement that the Player shall not be available for selection, attendance and/or appearance in a National Representative Team or National Squad of another Union during the term of that written agreement, including any extension thereof, provided that, prior to the execution of any such written agreement, the following conditions were satisfied:

- (a) The Player had reached the age of majority. For the purposes of the Regulation(s), the age of majority shall be deemed to be acquired by a Player on his 18th birthday.
- (b) Pursuant to Regulation 8, the Player was eligible to represent the senior or next senior National Representative Team of the Union with which he has entered into the written agreement and at least one other Union, (i.e., as a minimum requirement the Player had dual Union eligibility status).
- (c) The Player had not represented the senior or next senior National Representative Team of any Union in any of the Matches or Tours specified in Regulation 8.3.
- (d) As evidenced by completion of the standard form certification set out in Attachment 1, the Player received independent legal advice on the terms of the written agreement. In particular, the fact that in signing the written agreement the Player was acknowledging and accepting that during the course of the written agreement, and any extension thereof, he was foregoing his right to represent the senior or next senior National Representative Team of any other Union for which he may be eligible.

If, subject to compliance with the conditions set out in this Regulation 9.38, a Player's written agreement so provides, then that Player shall not be available for selection, attendance and/or appearance in a National Representative Team or National Squad of another Union during the term of the written agreement, or any extension thereof and during such period the Union with whom the Player is contracted shall have no obligation to release the Player to another Union.

**ATTACHMENT 1. CERTIFICATION FORM**

1. [ ] (“the Player”) warrants and agrees that the following statements are true:
- (a) The Player has received and understood independent legal advice from a qualified and practising lawyer as to the terms and effect of the written agreement with [ ] Union, dated [ ] [a copy of which is annexed hereto]. In particular, the Player warrants and agrees that he has received and understood the effect of the written agreement in respect of his unavailability during the course of the written agreement, and any extensions thereof, for selection, attendance and/or appearance in a National Representative Team or National Squad of any other Union for which he is or may become eligible under the World Rugby Regulations Relating to the Game.
  - (b) the qualified and practising lawyer referred to in paragraph (a) is [NAME] of the firm [FIRM'S DETAILS] (“the Advisor”).
2. The Advisor hereby warrants and agrees that the following statements are true:
- (a) The Advisor gave the Player the advice referred to in paragraph 1(a); and
  - (b) There was in force when the Advisor gave the advice referred to in paragraph 1(a) above a policy of insurance covering the risk of a claim by the Player in respect of any loss arising in consequence of the advice.

SIGNED AS A DEED

.....  
*Player Signature*

.....  
*Advisor Signature*

.....  
*Date*

.....  
*Date*

.....  
*Witnessed By*

.....  
*Witnessed By*

.....  
*Position*

.....  
*Position*

.....  
*Date*

.....  
*Date*

## APPENDIX 1, PART A

### Northern Hemisphere Unions:

Canada  
England  
France  
Ireland  
Italy  
Japan  
Scotland  
USA  
Wales

### Unions in membership of the following Regional Associations:

Rugby Europe  
Asia Rugby  
Rugby Americas North  
Rugby Africa – Northern Hemisphere Unions as follows:  
Algeria  
Benin  
Burkina Faso  
Burundi  
Cameroon  
Central Africa  
Chad  
Congo  
Democratic Republic of Congo  
Gabon  
Ghana  
Ivory Coast  
Kenya  
Libya  
Mali  
Mauritania  
Morocco  
Niger  
Nigeria  
Senegal  
Togo  
Tunisia

---

**APPENDIX 1, PART B****Northern Hemisphere International Matches, Tours and Tournaments:**

The Six Nations Championship or any successor Tournament

Rugby Europe European Nations Cup or any successor Tournament

Asian 5 Nations or any successor Tournament

Rugby Americas North Senior Men's Championship or any successor Tournament

Such other International Matches, Tours and Tournaments to be played in the Northern Hemisphere window as determined from time to time by Council

## **APPENDIX 2, PART A**

### **Southern Hemisphere Unions:**

Argentina  
Australia  
Fiji  
New Zealand  
Samoa  
South Africa  
Tonga

### **Unions in membership of the following Regional Associations:**

FORU  
Sudamérica Rugby  
Rugby Africa – Southern Hemisphere Unions as follows:  
    Botswana  
    Mauritius  
    Namibia  
    Rwanda  
    Seychelles  
    Swaziland  
    Tanzania  
    Uganda  
    Zimbabwe

### **Southern Hemisphere Unions from June 1, 2012:**

Fiji  
Samoa  
Tonga

### **Four Nations Unions from June 1, 2012:**

Argentina  
Australia  
New Zealand  
South Africa



---

**APPENDIX 2, PART B****Southern Hemisphere International Matches, Tours and Tournaments:**

The Tri Nations Championship or any successor Tournament

Pacific Nations Cup or any successor Tournament

Rugby Africa Africa Cup (senior Rugby Africa Unions) or any successor Tournament

Rugby Africa Development Trophy (associate member Rugby Africa Unions) or any successor Tournament

Sudamérica Rugby Senior Men's A or any successor Tournament

Sudamérica Rugby Senior Men's B or any successor Tournament

OCEANIA Cup or any successor Tournament

Such other International Matches, Tours and Tournaments to be played in the Southern Hemisphere window as determined from time to time by Council

**Southern Hemisphere International Matches, Tours and Tournaments from June 1, 2012:**

Pacific Nations Cup or any successor Tournament

Rugby Africa Africa Cup (senior Rugby Africa Unions) or any successor Tournament

Rugby Africa Development Trophy (associate member Rugby Africa Unions) or any successor Tournament

Sudamérica Rugby Senior Men's A or any successor Tournament

Sudamérica Rugby Senior Men's B or any successor Tournament

OCEANIA Cup or any successor Tournament

Such other International Matches, Tours and Tournaments to be played in the Southern Hemisphere window as determined from time to time by Council

**Four Nations Tournaments from June 1, 2012:**

The Four Nations Championship (formerly the Tri-Nations Championship)

## APPENDIX 3

### 1. Definitions

For the purposes of this Regulation 9 the terms below shall have the following meanings assigned to them:

**Career-Ending Injury** means an injury to a Player which wholly and continually prevents him from participating in the Game and where no recovery to permit the Player to resume participating in the Game is foreseeable;

**Catastrophic Injury** means an injury to a Player which wholly and continually prevents him from participating in any and every occupation including the Game and where no recovery is foreseeable;

**Emoluments** means Guaranteed Payments less any amounts which are or will be received by a Player from his Primary Employer, if that Primary Employer is a Rugby Body or Club, during the Player's period of incapacitation from playing the Game so as to represent the real economic loss in each case with respect to Guaranteed Payments;

**Guaranteed Payments** means the actual payments guaranteed to a Player for a one-year period from the date of the injury in respect of playing the Game by a Rugby Body or Club where that Rugby Body or Club is the Player's Primary Employer;

**International Duty** means representing, playing for, training and/or preparing with a senior National Representative Team and/or a National Squad;

**Medical Expenses** means the actual cost of medical expenses incurred in treating an injury to a Player, excluding, without limitation, pioneering or alternative treatments, international travel for treatment other than travel to the Player's home country and any other expenses above the ordinary cost of the necessary treatment. World Rugby will have the final decision in respect of any dispute in relation to the foregoing;

**Primary Employer** means an employer for whom a Player is required, pursuant to a written agreement, to provide services for a minimum of 75% of his Working Time;

**Temporary Total Disablement** means an injury to a Player which temporarily and totally prevents him from participating in the Game but is not a Catastrophic Injury or Career-Ending Injury; and "Temporarily Totally Disabled" shall be construed accordingly; and

**Working Time** means the total time a Player is available to provide services whether such services are provided to the Primary Employer or otherwise.

## **2. Liability for Players when on International Duty**

- 2.1** Where a Player has been released pursuant to Regulation 9 the Union is responsible for and shall have in place appropriate financial arrangements or insurance to cover the Player and/or where applicable his Primary Employer in respect of losses and expenses incurred as a result of injury sustained when the Player is on International Duty subject to the limits set out in Section 3 hereunder.
- 2.2** The cover referred to in Section 2.1 above shall include Medical Expenses, loss of Emoluments, Temporary Total Disablement, Career-Ending Injury and Catastrophic Injury incurred as a result of injury sustained at the time when the Player is on International Duty.

## **3. Minimum Cover**

- 3.1** The minimum financial limits and the terms and conditions of the cover to be provided pursuant to Section 2 above will be agreed or specified by World Rugby from time to time but will not be less than:
- (a) In the case of a Catastrophic Injury: £1 million sterling;
  - (b) Where a Player sustains a Career-Ending Injury and is aged on the date of the incident:
    - (i) 29 years of age or less; his Guaranteed Payments (save where such Guaranteed Payments are more than £225,000 sterling they shall be deemed to be £225,000 sterling);
    - (ii) between 30 and 32 years of age (inclusive); 66% of his Guaranteed Payments (save where such Guaranteed Payments are more than £225,000 sterling they shall be deemed to be £225,000 sterling);
    - (iii) 33 years of age and over; 33% of his Guaranteed Payments (save where such Guaranteed Payments are more than £225,000 sterling they shall be deemed to be £225,000 sterling);
  - (c) Where a Player is Temporarily Totally Disabled: his Guaranteed Payments (save where such Guaranteed Payments are more than £225,000 sterling they shall be deemed to be £225,000 sterling), on a pro-rata basis for the period of time during which he is unable to participate in the Game to a maximum of one year from the date of the injury, and ending 7 days prior to the date he is able to resume participating in the Game;
  - (d) The cost of any and all Medical Expenses.

4. A Union may but is not obliged to agree with a Player or where applicable his Primary Employer to provide greater or more extensive cover than the minimum provided for in Section 3.1 above.
5. In the event that a Union does not satisfy the requirements of this Appendix 3 World Rugby may take such action as it considers appropriate.

## REGULATION 10. MEDICAL

Concussion is a brain injury, which is serious and can be suffered by a Player of any age.

Concussion and suspected concussion must be taken extremely seriously by all those involved in the Game in order to protect the safety, health and welfare of Players.

Extra caution must also be taken with children and adolescents who have a greater risk of concussion and associated complications.

### 10.1 Concussion

#### ADULTS

10.1.1 Any ADULT Player with concussion or suspected concussion:

- (a) must be immediately and permanently removed from training or the field of play; and
- (b) should be assessed by a medical practitioner or an approved healthcare professional (as approved in the relevant jurisdiction); and
- (c) must not return to training or to play in a Match on the same day and until symptom free; and
- (d) must have complete physical and cognitive rest for 24 hours; and
- (e) must have relative physical rest (activity that does not induce or aggravate symptoms) for at least one week (including the initial 24 hour period of complete physical and cognitive rest) before commencing a graduated return to play (GRTP) programme referred to at 10.1.1(f)-(g) below. The Player must be symptom free before commencing the GRTP; and
- (f) must successfully follow and complete a GRTP programme which must be consistent with World Rugby's GRTP Protocol contained in the World Rugby Concussion Guidance which is available [here](#); and
- (g) should receive clearance from a medical practitioner or approved healthcare professional prior to commencing the full contact training stage of the GRTP programme.

10.1.2 The following exceptions may apply:

- (a) The one week rest period (in 10.1.1(e)) is obligatory regardless of whether the Player has become symptom free unless the Player has successfully accessed an 'advanced level of concussion care' (as defined in the World Rugby Concussion Protocol). In any event, there is no exception to the initial 24 hour period of complete physical and cognitive rest;

- (b) the completion of a GRTP programme stipulated in 10.1.1(f) is obligatory except in cases of suspected concussion where the Player has accessed an 'advanced level of concussion care' (as defined in the World Rugby Concussion Protocol) AND has been medically cleared to return to training or to play on the grounds that the Player had not in fact been concussed.
- 10.1.3 The temporary replacement procedure for head injury assessment set out in Law 3.11 is only applicable in elite adult Matches, Series of Matches or Tournaments, which have been approved in advance by World Rugby.
- 10.1.4 If a Union, Association or Tournament Organiser wishes to obtain access to temporary replacement for head injury assessment in approved elite adult rugby Matches, an application for approval must be made to World Rugby. Application procedures are set out in the World Rugby Head Injury Assessment Protocol ("HIA Protocol") available for elite level match day medical staff [here](#).
- 10.1.5 Approval will only be given by World Rugby for access to the temporary replacement procedure in the elite adult game if the relevant approval criteria identified in the HIA Protocol are met, which include confirmation by the applicant that:
  - (a) The Tournament or Matches are elite adult Tournaments or Matches;
  - (b) The Core (mandatory) Concussion Player Welfare Standards set out in the HIA Protocol will be adopted and complied with;
  - (c) There will be an Untoward Incident Review system in place; and
  - (d) They have facilitated access to video to assist with the management of head impact events occurring during Matches.

### **CHILDREN AND ADOLESCENTS**

- 10.1.6 Any CHILD or ADOLESCENT Player (aged 18 years or less) with concussion or suspected concussion:
  - (a) must be immediately and permanently removed from training or the field of play; and
  - (b) should be medically assessed by a medical practitioner or an approved healthcare professional (as approved in the relevant jurisdiction); and
  - (c) must not return to training or to play in a Match on the same day and until symptom free; and
  - (d) must have complete physical and cognitive rest for 24 hours; and
  - (e) must have relative physical rest (activity that does not induce or aggravate symptoms) for at least two weeks (including an initial 24 hour period of complete physical and cognitive rest) before

commencing the graduated return to play (GRTP) programme referred to at 10.1.6(f)-(g) below. The Player must be symptom free before commencing the GRTP; and

- (f) must successfully follow and complete a GRTP programme, which must be consistent with World Rugby's GRTP programme contained in the World Rugby Concussion Guidance which is available at [here](#); and
- (g) should receive clearance from a medical practitioner or approved healthcare professional prior to commencing the full contact training stage of the GRTP programme.

10.1.7 The following exceptions may apply:

- (a) The two week rest period (in 10.1.6(e)) is obligatory regardless of whether the Player has become symptom free unless the Player has successfully accessed an 'advanced level of concussion care' (as defined in the World Rugby Concussion Protocol). In any event, there is no exception to the initial 24 hour period of complete physical and cognitive rest;
- (b) the completion of a GRTP programme stipulated in 10.1.6(f) is obligatory except in cases of suspected concussion where the Player has accessed an 'advanced level of concussion care' (as defined in the World Rugby Concussion Protocol) AND has been medically cleared to return to training or to play on the grounds that the Player had not in fact been concussed.





## REGULATION 11. ADVERTISING WITHIN THE PLAYING ENCLOSURE

### 11.1 Definitions

The following definitions apply to this Regulation 11:

**Advertising Mark** means a mark of a sponsor, partner or other advertiser authorised by the Union, Association or World Rugby with responsibility for the team and/or Match Officials.

**Competition Mark** means the mark of the competition, series or tournament in which the team is competing.

**Manufacturer Mark** means a mark of the manufacturer of the particular item of apparel or equipment.

**Mark** means any logo, trademark, emblem, crest, name, flag and/or number, whether registered or unregistered.

**Team Emblem/National Flag** means the emblem of the team as designated by the Union from time to time and/or the national flag of the country of the Union.

**Top** means a jersey, tracksuit or warm-up top or similar item worn on the upper half of the body.

**World Rugby/Association/Union Emblem/Crest** means the emblem or crest of World Rugby, Association or Union as designated by World Rugby, Association or Union from time to time.

### 11.2 General

11.2.1 This Regulation deals with Marks on Persons and/or the clothing of Persons or on any other items worn, used or displayed on the playing enclosure. This Regulation 11 sets out the maximum size (taken as a block in square centimetres) and the maximum permitted number, type and location of such Marks.

11.2.2 The rules and regulations of a Union, Association, Rugby Body or Club may limit or restrict the content, number and/or size of Marks permitted by this Regulation for both National Representative Teams and other teams under their jurisdiction.

11.2.3 Unions have discretion to apply such Marks with respect to their National Representative Teams as they consider appropriate, subject to the limitations set out in this Regulation 11, Regulation 6.5(i) and Regulation 7.5.

11.2.4 Subject to Regulation 7.5, Unions or Associations may permit less stringent restrictions than those set out in this Regulation 11 below National Representative Team level, provided that such regulations do not detract from the essential character or integrity of Players' and Match Officials' Rugby Union kit.

- 11.2.5 The designated size of Marks shall be calculated by drawing a block around the outline of the mark as displayed on the item and includes any blank space(s) within the block. This means that every element of the Mark must be incorporated within the dimensions of the block. See example:



- 11.2.6 No other Marks other than those specifically permitted within this Regulation 11 are permitted.

### 11.3 Team Kit

- 11.3.1 This Regulation 11.3 set out the specific regulations which apply to the display of Marks on National Representative Team kit worn on the playing enclosure, comprising jersey, tracksuit Top, warm-up Top, playing and warm-up shorts, tracksuit bottoms and socks (and/or any similar items).

#### Colour References

1	Green	Union Emblem/Crest
2	Red	Competition Mark
3	Yellow	Advertising Mark
4	Blue	Manufacturer Mark
5	Pink	Team Emblem/National Flag

The numbers and colours appearing in the diagrams within this Regulation 11.3 correspond to the above reference table.

## 11.3.2 Playing and Warm-Up Jersey

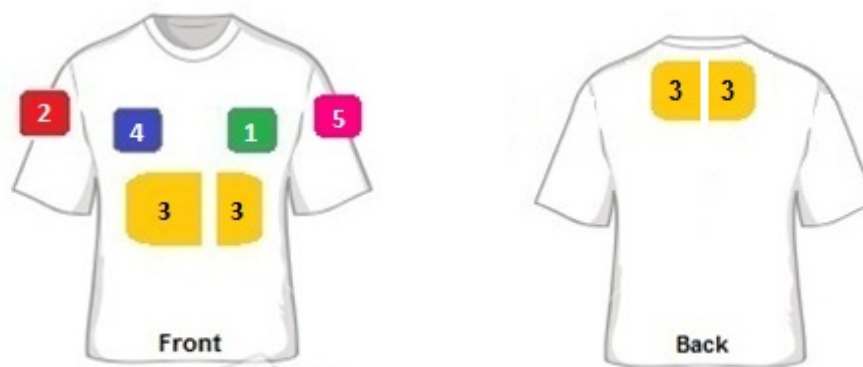

The diagram above depicts the Marks which are permitted to be displayed on the jerseys of National Representative Teams worn on the playing enclosure and no other Marks are permitted. The recommended locations of the Marks are indicated in the diagram above, however they may appear anywhere on the jersey, subject to the restrictions set out below:

- (a) One of each of the Union Emblem/Crest, Competition Mark, Manufacturer Mark and Team Emblem/National Flag are permitted but must not exceed 100cm<sup>2</sup> each in total.
- (b) One Advertising Mark on the front of the jersey which must not exceed 300cm<sup>2</sup> in total.
- (c) The Advertising Mark on the front of the playing jersey can be split into two separate Advertising Marks but the combined total size must not exceed 300cm<sup>2</sup>.
- (d) One Advertising Mark on the back of the jersey which must not exceed 180cm<sup>2</sup> in total.
- (e) The Advertising Mark on the back of the jersey can be split into two separate Advertising Marks but the combined total size must not exceed 180cm<sup>2</sup>.
- (f) The Advertising Marks on the front and back of the jersey may be different. Where the Advertising Mark is split each Advertising Mark may be different.
- (g) A maximum of four Advertising Marks are permitted on the jersey.
- (h) In addition to the one National Flag permitted at (a) above, the National Flag or elements thereof may be integrated into the overall design of the jersey provided they are clearly design elements and not actual or perceived additional Marks in and of themselves.

### 11.3.3 Playing and Warm-Up Shorts



The diagram above depicts the Marks which are permitted to be displayed on shorts of National Representative Teams worn on the playing enclosure and the recommended locations, subject to the restrictions set out below:

- (a) The Union Emblem/Crest must not exceed 100cm<sup>2</sup>.
- (b) The Manufacturer Mark must not exceed 80cm<sup>2</sup>.
- (c) The two Advertising Marks must not exceed 100cm<sup>2</sup> each. These may be placed at any location on the back of shorts.

### 11.3.4 Playing and Warm-Up Socks



The only Mark which is permitted to be displayed on socks of National Representative Teams worn on the playing enclosure is the Manufacturer Mark, which must not exceed 15cm<sup>2</sup>. This can be placed once at any location on socks.

## 11.3.5 Tracksuit or similar Warm-Up Top

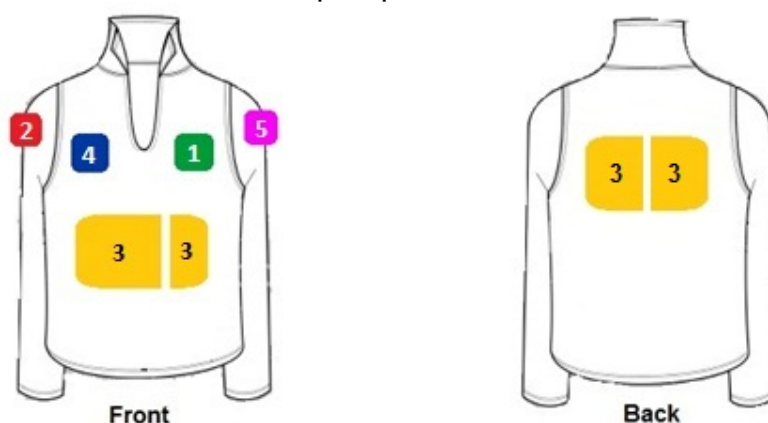

The diagram above depicts the Marks which are permitted to be displayed on the tracksuit or similar warm-up Top of National Representative Teams worn on the playing enclosure. The recommended locations of the Marks are indicated in the diagram above, however they may appear anywhere on the tracksuit/warm-up Top, subject to the restrictions set out below:

- (a) One of each of the Union Emblem/Crest, Competition Mark, Manufacturer Mark and Team Emblem/National Flag are permitted but must not exceed 100cm<sup>2</sup> each.
- (b) One Advertising Mark on the front of the tracksuit/warm-up Top which must not exceed 300cm<sup>2</sup> in total.
- (c) The Advertising Mark on the front of the tracksuit/warm-up Top can be split into two separate Advertising Marks but the combined total size must not exceed 300cm<sup>2</sup>.
- (d) One Advertising Mark on the back of the tracksuit/warm-up Top which must not exceed 180cm<sup>2</sup> in total.
- (e) The Advertising Mark on the back of the tracksuit/warm-up Top can be split into two separate Advertising Marks but the combined total size must not exceed 180cm<sup>2</sup>.
- (f) The Advertising Marks on front and back may be different. Where the Advertising Mark is split each Advertising Mark may be different.
- (g) A maximum of four Advertising Marks are permitted on the tracksuit/warm-up Top.
- (h) In addition to the one National Flag permitted at (a) above, the National Flag or elements thereof may be integrated into the overall design of the tracksuit/warm-up Top provided they are clearly design elements and not actual or perceived additional Marks in and of themselves.

For the avoidance of doubt, the Advertising Marks appearing on the tracksuit or similar warm-up Top may be different to those which appear on the playing jersey.

### 11.3.6 Tracksuit Bottom

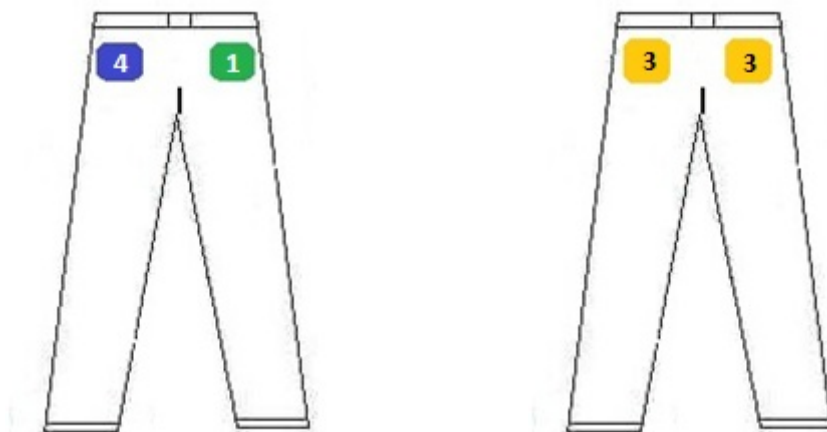

The diagram above depicts the Marks which are permitted to be displayed on the tracksuit bottoms of National Representative Teams worn on the playing enclosure. The recommended locations of the Marks are indicated in the diagram above, however they may appear anywhere on the tracksuit bottoms, subject to the restrictions set out below:

- (a) One Union Emblem/Crest which must not exceed 100cm<sup>2</sup>.
- (b) One Manufacturer Mark which must not exceed 80cm<sup>2</sup>.
- (c) Up to two Advertising Marks which must not exceed 100cm<sup>2</sup> each. These may only appear on the back of tracksuit bottoms.

For the avoidance of doubt, the Advertising Marks appearing on the tracksuit bottoms may be different to those which appear on the shorts.

### 11.3.7 Player's Number and Name

A Player's number and/or name may be displayed once on any item of Team kit (excluding socks) set out above and on boots in accordance with Regulation 11.6 below. The number must be clearly displayed on the back (only) of Players' jerseys. No number or name anywhere on Team kit may contain a Mark(s).

## 11.4 Match Officials' Kit

- 11.4.1 This Regulation 11.4 sets out the specific regulations which apply to Marks on Match Officials' kit comprising jersey, tracksuit Top, warm-up Top, Match and warm-up shorts, tracksuit bottoms and socks (and/or any similar items) worn on the playing enclosure for International Matches.

## Colour References

1	Grey	World Rugby/Association/Union Emblem/Crest
2	Red	Competition Mark
3	Yellow	Advertising Mark
4	Blue	Manufacturer Mark

The numbers and colours appearing in the diagrams within this Regulation 11.4 correspond to the above reference table.

## 11.4.2 Match Officials' Jersey

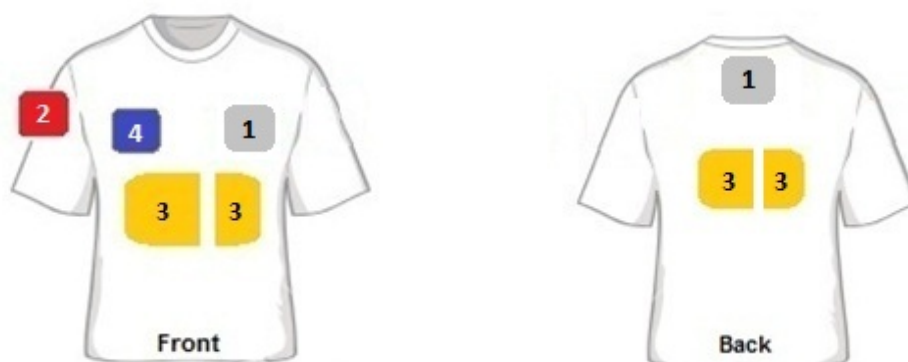

The diagram above depicts the Marks which are permitted to be displayed on the Match Officials' jersey. The recommended locations of the Marks are indicated in the diagram above, however they may appear anywhere on the jersey, subject to the restrictions set out below:

- One of each of World Rugby/Association/Union Emblem/Crest, Competition Mark and Manufacturer Mark are permitted but must not exceed 100cm<sup>2</sup> each.
- One Advertising Mark on the front of the jersey which must not exceed 300cm<sup>2</sup> in total.
- The Advertising Mark on the front of the Match Officials' jersey can be split into two separate Advertising Marks but the combined total size must not exceed 300cm<sup>2</sup>.
- One Advertising Mark on the back of the Match Officials' jersey which must not exceed 180cm<sup>2</sup> in total.
- The Advertising Mark on the back of the Match Officials' jersey can be split into two separate Advertising Marks but the combined total size must not exceed 180cm<sup>2</sup>.

- (f) The Advertising Marks on the front and back of the Match Officials' jersey may be different. Where the Advertising Mark is split each Advertising Mark may be different.

#### 11.4.3 Match Officials' Shorts



The diagram above depicts the Marks which are permitted to be displayed on Match Officials' shorts and the recommended locations, subject to the restrictions set out below:

- (a) World Rugby/Association/Union Emblem/Crest must not exceed 100cm<sup>2</sup>.
- (b) The Manufacturer Mark must not exceed 80cm<sup>2</sup>.

#### 11.4.4 Match Officials' Socks



The only Mark which is permitted to be displayed on Match Officials' socks is the Manufacturer Mark, which must not to exceed 15cm<sup>2</sup>. This can be placed once at any location on Match Officials' socks.

#### 11.4.5 Match Officials' Tracksuit or Warm-Up Apparel

Regulations 11.3.5 and 11.3.6 shall apply equally to Match Officials' tracksuits and/or warm-up apparel save that:

- (a) World Rugby or Association Emblem/Crest may be displayed on Match Officials' tracksuits in place of the Union Emblem/Crest.
- (b) No Team Emblem/National Flag may be displayed on Match Officials' tracksuits. This mark may not be replaced by another mark.



## 11.5 Baselayer and shoulder/chest pads

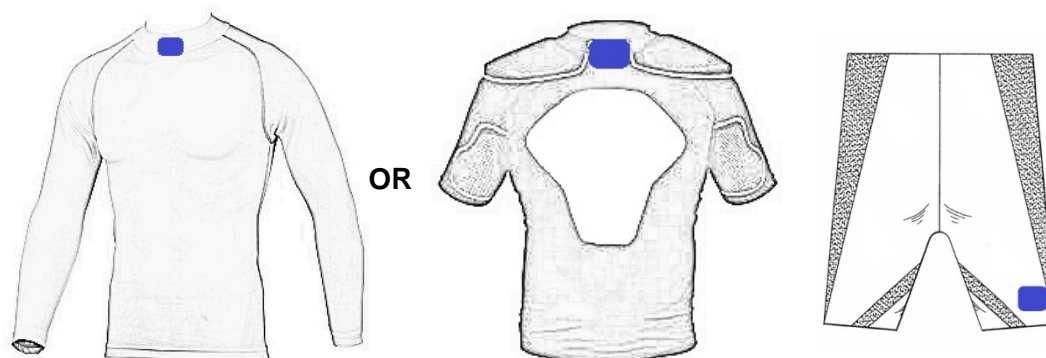

11.5.1 The diagram above depicts the Marks which are permitted to be displayed on baselayers and shoulder and chest pads worn on the playing enclosure in International Matches (by Players and Match Officials) and the stipulated locations, subject to the further restrictions set out below:

- (a) The Manufacturer Mark must not to exceed 25cm<sup>2</sup>. Strictly subject to (b) below this may be placed once on each item in the locations stipulated in the diagram above only and no other logo may be visible outside the jersey and shorts.
- (b) Players may not wear a baselayer top and shoulder or chest padding where both, when worn together, visibly display a Manufacturer's Mark. Only one Manufacturer's Mark may be visibly displayed in total on such items however many are worn.
- (c) The baselayer shorts must not extend over or below the knee. The baselayer top and shorts must be either black or the same colour as the predominant colour of the jersey or shorts worn respectively.
- (d) No other Marks may be displayed on baselayers and shoulder and chest pads.

## 11.6 Boots

11.6.1 This Regulation 11.6 sets out the specific regulations which apply to the display of Marks on boots worn on the playing enclosure in International Matches.

11.6.2 The Manufacturer Mark, name and/or emblem may be displayed on boots.

11.6.3 The given name(s), surname(s), or initials, the number of International Match Caps, and, in the case of Players only the Team Emblem/National Flag, may also be displayed once on each boot. No other Marks, including commercial name(s), Advertising Mark(s), and/or social media identifiers

or similar, may be displayed on boots. The suggested location for the Manufacturer Mark displayed on boots is set out in the diagram below.



## 11.7 Additional Items of Clothing

11.7.1 This Regulation 11.7 sets out the specific regulations which apply to the display of Marks on additional items of clothing worn or used on the playing enclosure in International Matches.

11.7.2 One Manufacturer Mark of a maximum total area (taken as a block in square centimetres) of 25cm<sup>2</sup> may be displayed in any location on the additional items of clothing depicted in the diagrams below.

11.7.3 Marks may not be displayed on any other items.

### *Supports*

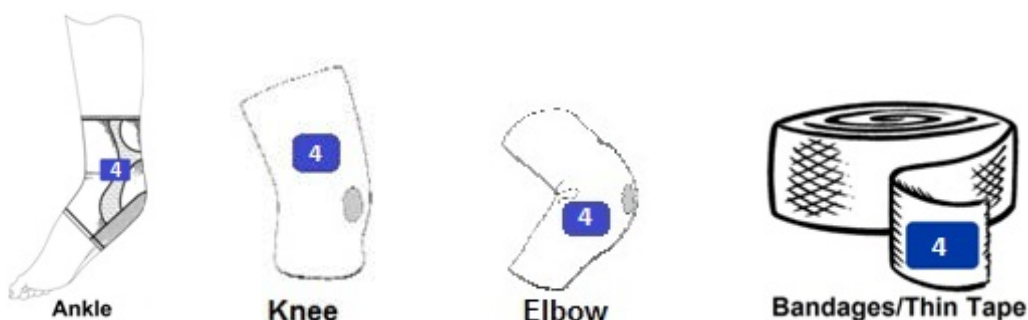

### *Other*

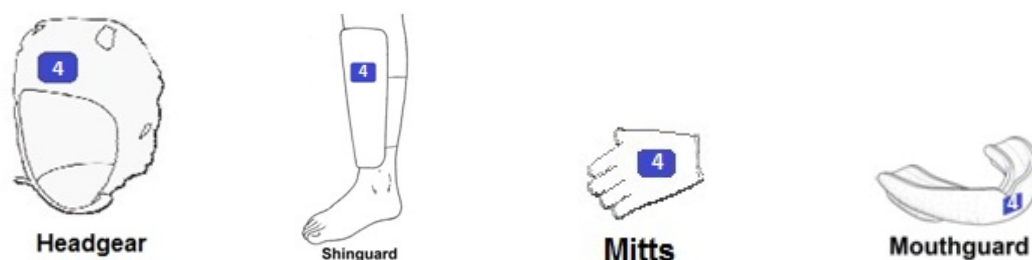

11.7.4 Mouth guards:

In addition to the Manufacturer's Mark set out above, the National Flag of the Union of the wearer may be incorporated into the design and/or colour scheme of mouth guards (but not other additional items of clothing). Mouth guards may not be branded other than with the Manufacturer's Mark and may not be designed in the corporate colours of any sponsor, partner or other advertiser of the Player and/or Union.

## 11.8 Medical Case

- 11.8.1 Medical cases brought onto the playing enclosure in International Matches may display one Advertising Mark of a maximum total area of 160cm<sup>2</sup> and one Team Emblem/National Flag of a maximum total area of 100 cm<sup>2</sup>. The recommended locations for the permitted Marks are depicted in the diagram below.

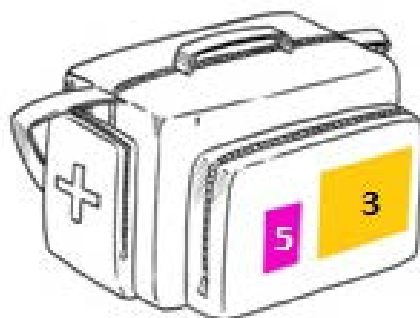

## 11.9 Emblems, Marks and/or names of special national significance

- 11.9.1 A Union, having obtained the written approval of the host Union, may apply to the Regulations Committee ordinarily three months in advance of the date of intended use for permission to display an emblem, mark and/or name of special national significance in a particular Match which would otherwise not be permitted under Regulation 11.3. In the absence of such permission being granted the Union shall not display such emblem, mark and/or name.
- 11.9.2 The emblem, mark and/or name pursuant to Regulation 11.9.1, if approved, shall be displayed only on the Players' jerseys and shall be of a size no greater than the permitted Manufacturer Mark in Regulation 11.3.1.

## 11.10 Playing Enclosure

- 11.10.1 Subject to the decision of the relevant Match or tournament organiser and to Regulation 11.10.2 below, emblems, Marks and/or names of Unions, Associations, Rugby Bodies, Clubs, manufacturers, advertisers and/or sponsors may be displayed on the playing surface, standing touch flags or assistant referees' flags and rugby balls.
- 11.10.2 The Union, Association, Rugby Body, Club or tournament organiser under whose jurisdiction a Match is played shall be responsible for ensuring that any markings used in accordance with 11.10.1 above:
- do not in any way obscure or visually impair the line markings of the playing surface as defined in Law 1;
  - do not in any way constitute a safety hazard to Players, Match Officials or spectators or disrupt, in any way, the playing, spectating or viewing of a Match; and

(c) are made or applied using substances which will not in any circumstances, mark Players or a Player's kit, or otherwise lose their definition during any Match.

11.10.3 No form of emblem, mark or name of an advertiser or sponsor (as opposed to a Union, Association, Rugby Body or Club) may be displayed on goal posts or crossbars. This does not apply to padding and protectors on the goal posts up to a height of two metres from the ground.

#### **11.11 Miscellaneous**

11.11.1 Save for the emblems or Marks of Unions, Associations, Rugby Bodies or Clubs and as otherwise expressly provided in this Regulation 11, no form of emblem, Mark, name or other form of commercial and/or promotional association may be displayed on any item worn, used, placed or carried onto the playing enclosure, or on a Person themselves, that is not referred to in Regulations 11.3 to 11.8 or specifically authorised under Regulation 11.9.2.

11.11.2 Teams consisting solely of Players under the age of contractual capacity on 1st January during or immediately prior to the current season, including but not limited to school teams, shall not be permitted to display advertising on Players' clothing publicising companies whose products, services or activities may be considered by the Union or Association to be detrimental to Players of that age.

11.11.3 Nothing which may be regarded by the Union or Association in its absolute discretion as distasteful or ethically or morally undesirable or which brings the Game into disrepute shall be displayed.

**REGULATION 12. PROVISIONS RELATING TO PLAYERS' DRESS**

For all matches, Unions, Associations, Rugby Bodies, Clubs, Players and Persons must ensure that the provisions relating to Players' dress, set out in this Regulation, and the specifications set out in Schedule 1 and Schedule 2, are complied with in full. The Council may, from time to time, supplement, amend and/or modify, in whole or in part, the provisions relating to Players' dress set out in this Regulation and/or the specifications set out in Schedule 1.

Below are the three World Rugby Approved Clothing labels. All are valid and on display on the World Rugby Player Welfare website ([www.worldrugby.org/playerwelfare](http://www.worldrugby.org/playerwelfare)).

**World Rugby Approved Clothing Labels**

## SCHEDULE 1. SPECIFICATIONS RELATING TO PLAYERS' DRESS

### LAW 4 – PLAYERS' CLOTHING

#### 1. Additional items of clothing

(a) Shin Guards

A player may wear shin guards worn under the socks with padding incorporated in non-rigid fabric with no part of the padding thicker than 0.5cm when compressed.

(b) Fingerless Mitts

Coverage of the fingers and thumbs be permitted to the outer joint but no further. The mitt zone of coverage should not continue beyond the wrist.

The body of the mitt should be of a stretch type material with the grip material being made of a soft rubber/synthetic compound not exceeding a depth of 1mm.

No part of a mitt should contain buttons or potentially dangerous items.

(c) Shoulder Pads\*

A player may wear shoulder pads, made of soft and thin materials, which may be incorporated in an undergarment or jersey provided that the pads cover the shoulder and collar bone only. No part of the pads may be thicker than 1cm when uncompressed. No part of the pads may have a density of more than 45 kilograms per cubic metre.

(d) Headgear\*

A player may wear headgear made of soft and thin materials provided that no part of the headgear is thicker than 1cm when uncompressed and no part of the headgear has a density of more than 45 kilograms per cubic metre.

(e) Player Monitoring Devices

A player may wear a player monitoring device which complies with the requirements as set out in the World Rugby Performance Specification for Player Monitoring Devices<sup>1</sup>

\* *Shoulder Pads, Headgear, Breast Padding (Women) must conform to the Standard Performance Specification for Specific Items of Players' Clothing (Schedule 1 hereto).*

<sup>1</sup> *The approved trial of global positioning system devices shall conclude on 30 June 2017.*

## 2. Special additional items for women

### Breast Padding\*

Besides the previous items, women may wear breast pads made of soft and thin materials which may be incorporated as part of a garment provided that the pads cover the shoulder and/or collar bone and/or chest only with no part of the pads thicker than 1cm when uncompressed and no part of the pads having a density of more than 45 kilograms per cubic metre.

## 3. Studs

Studs of players' boots must conform to the "Safety Aspects of Rugby Boot Sole Design" set out below:" (Schedule 2 hereto).

## 4. Banned items of clothing

Other than the items of clothing set out at 1(a)-(d), 2 and 3 above, a player must not wear any item of which any part is thicker than 0.5cm when uncompressed or is denser than 45 kilograms per cubic metre unless specified within this Regulation 12/Law 4. Where this overall thickness consists of padded material covered by fabric, 0.5 cm is the maximum measured thickness for the combination of the uncompressed padding and the fabric. The fabric can contribute up to a maximum measured thickness of 1 mm on each side of the padding.

### **When Designation: IBR/REG12/Iss 1/2005 Standard Performance Specification for Specific Items of Players' Clothing**

The above designation is set. The number immediately following World Rugby indicates the year of issue while the letter designates the issue of that year. At all times the latest issue applies.

This standard concerns manufacturers and testers of Rugby players' clothing and should be read in conjunction with the current version of the World Rugby's LAW 4 concerning players' dress and Regulation 12. Particular attention is drawn to Regulation 12, Schedule 1, Clause 4.4 (g) – set out below.

#### 4.4 (g) Banned items of clothing

A player must not wear any item of which any part is thicker than 0.5 cm when uncompressed or is denser than 45 kilograms per cubic metre unless specified within this Regulation 12/Law 4. Where this overall thickness consists of padded material covered by fabric, 0.5 cm is the maximum measured thickness for the combination of the uncompressed padding and the fabric. The fabric can contribute up to a maximum measured thickness of 1 mm on each side of the padding.

---

\* *Shoulder Pads, Headgear, Breast Padding (Women) must conform to the Standard Performance Specification for Specific Items of Players' Clothing (Schedule 1 hereto).*

## Introduction

Rugby is a contact sport with intrinsic hazards. Padding equipment is worn by rugby players to reduce the severity and frequency of injuries from impacts with other players or the playing surface. The intent of this standard is to specify requirements for rugby headgear, shoulder padding and breast padding without compromising the form or appeal of the game.

### 1. Scope

This standard sets requirements for headgear, shoulder padding and breast padding. General requirements relating to the ergonomics, construction, sizing and design of the equipment are specified. Performance requirements relating to impact attenuation and retention system strength and effectiveness (headgear only) are also provided, and the corresponding test methods are described. In addition, requirements for product marking and instructional literature are included.

### 2. Terminology

**Padding** – that padding worn on the body and head.

**Headgear** – that worn on the head by players.

**Shoulder Padding** – that padding worn on the shoulder area.

**Breast Padding** – that padding worn on the breast and axillary tail area.

**Zone of Coverage** – the area of padding that is intended to provide coverage.

**Retention System** – that which is used to secure the headgear or garment to the body.

**Chin Strap** – a strap that passes under the wearer's chin or lower jaw and is intended to retain the headgear on the head.

**g** – the acceleration due to gravity.  $g$  (standard) = 9.80665 m/s<sup>2</sup>.

**g<sub>max</sub>** – the maximum value of  $g$  encountered during impact.

### 3. Requirements – Headgear

#### 3.1 Ergonomics

Headgear should be designed and constructed to minimise discomfort for the wearer. All normal playing movements shall not be impeded by wearing the headgear.



## 3.2 Construction

### 3.2.1 Construction Materials

It is the manufacturer's responsibility that all materials used in the construction of the headgear should not be significantly affected by ultra-violet radiation, water, dirt, perspiration, toiletries, household soaps and detergents. All materials coming into contact with the wearer's body will not be of the type known to cause skin disorders and shall not cause abrasion of either the wearer or other players.

### 3.2.2 Padding Materials

Padding materials must be homogeneous (i.e. padding facing towards the wearer must be the same texture, hardness and density as that facing the opponent). Foam padding of sandwich construction is not allowed.

### 3.2.3 Finish

Headgear shall be so constructed that it is unlikely to cause any injury to the wearer or other players during play. There shall not be hard or sharp edges, seams, buckles or other items on the surface of the product that could harm the wearer or other players during normal use.

## 3.3 Design

### 3.3.1 Zones of Coverage

The headgear must have zones of coverage that cover the crown, temple, forehead (sweatband area) and ear areas. The zones of coverage shall fulfil the requirements of the impact performance specification (Section 3.4.1) and have a maximum padding thickness of 10mm+2mm tolerance band plus an additional allowance of 1mm on each side for fabric. The typical dimensions of the zones of coverage are given in Table 1. Areas outside designated zones of coverage do not have to meet impact requirements but must be of soft foam or leather and be less than or equal to 5mm in thickness. Where this overall thickness consists of padded material covered by fabric, 0.5 cm is the maximum measured thickness for the combination of the uncompressed padding and the fabric. The fabric can contribute up to a maximum measured thickness of 1 mm on each side of the padding. All padding materials must have a density not greater than 45 kg/m<sup>3</sup> + 15 kg/m<sup>3</sup> tolerance band.

**Table 1.**  
**Typical Dimensions of Zones of Coverage for Headgear**

Dimensions	XXS mm	XS mm	S mm	M mm	L mm	XL mm	XXL mm
<b>B</b>	56	58	63	70	75	75	75
<b>C</b>	81	85	89	97	104	106	108
<b>D</b>	132	136	140	147	155	158	160
<b>E</b>	50	50	50	50	50	50	50
<b>F</b>	> 25	> 25	> 25	> 25	> 25	> 25	> 25
<b>G*</b>	25 to 30	25 to 30	25 to 30	25 to 30	25 to 30	25 to 30	25 to 30

\*see Ear Aperture section 3.3.2

**Figure 1.**  
**Typical zones of Coverage for Headgear**

Sizes are based on the following:

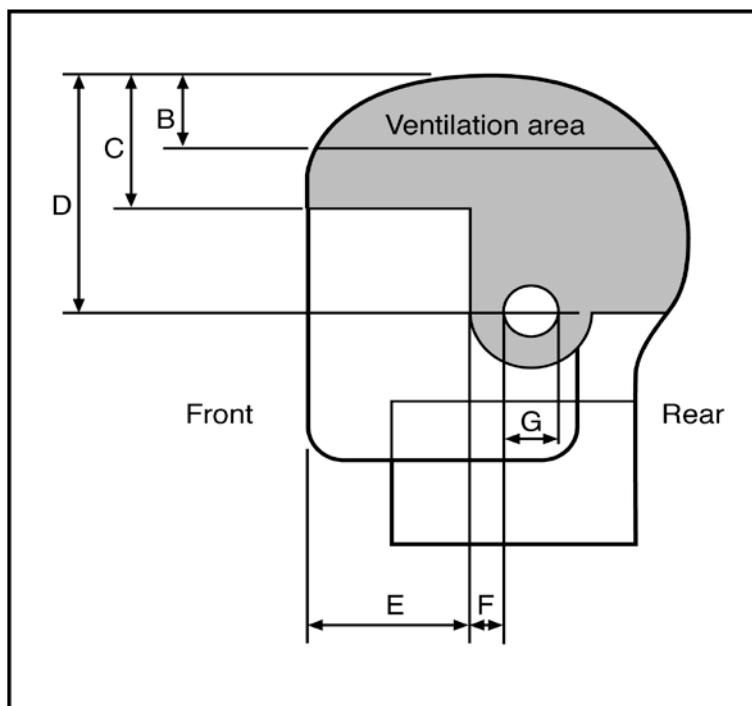

**Table 2.**  
**Head sizes**

Diameter (cm)	50 51	52 53	54 55	56 57	58 59	60 61	62 63
<b>Size</b>	6 <sup>1</sup> / <sub>4</sub> 6 <sup>3</sup> / <sub>8</sub>	6 <sup>1</sup> / <sub>2</sub> 6 <sup>5</sup> / <sub>8</sub>	6 <sup>3</sup> / <sub>4</sub> 6 <sup>7</sup> / <sub>8</sub>	7 7 <sup>1</sup> / <sub>8</sub>	7 <sup>1</sup> / <sub>4</sub> 7 <sup>3</sup> / <sub>8</sub>	7 <sup>1</sup> / <sub>2</sub> 7 <sup>5</sup> / <sub>8</sub>	7 <sup>3</sup> / <sub>4</sub> 7 <sup>7</sup> / <sub>8</sub>
	XXS	XS	S	M	L	XL	XXL

### 3.3.2 Ear Aperture

The ear aperture of the headgear shall have a linear dimension (G) not less than 25mm and not more than 30mm. It may have a cross mesh or similar design characteristic but this must not significantly affect the hearing of the wearer. Where a cross mesh is used, the linear dimension of any ear apertures shall not exceed 30 mm.

### 3.3.3 Vision

Horizontal field: the headgear shall provide peripheral vision clearance of at least 105° to each side of the longitudinal vertical line (median plane) when the headgear is positioned in accordance with the Manufacturer's Instructions (see Figure 2). Vertical field: the headgear shall provide peripheral vision clearance of 25° above the Apex plane when the headgear is positioned in accordance with the Manufacturer's Instructions. Vision will not be hindered below the Apex plane (see Figure 3).

**Figure 2.**  
**Horizontal Field of Vision Requirement**

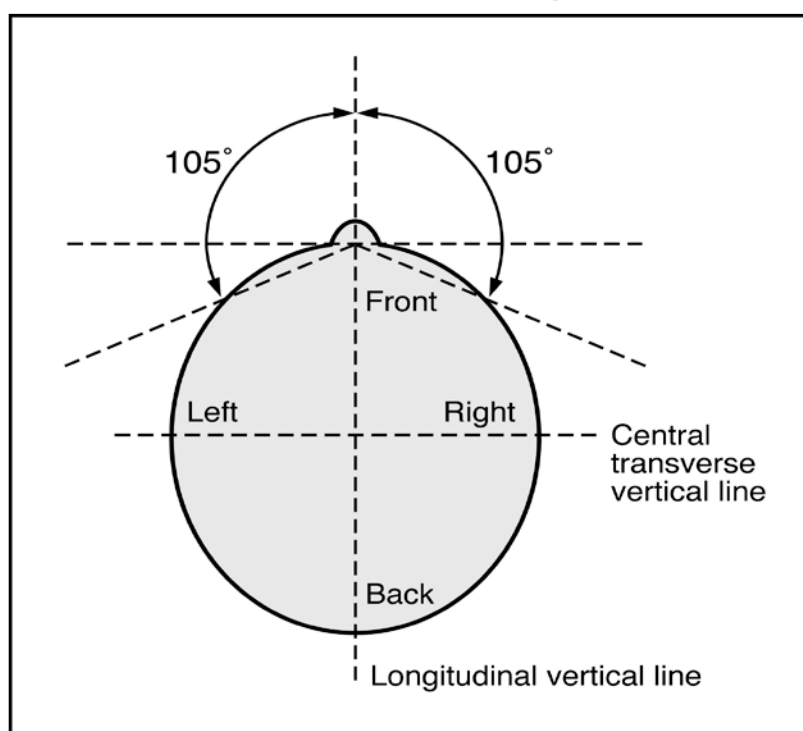

**Figure 3.**  
**Vertical Field of Vision Requirement**

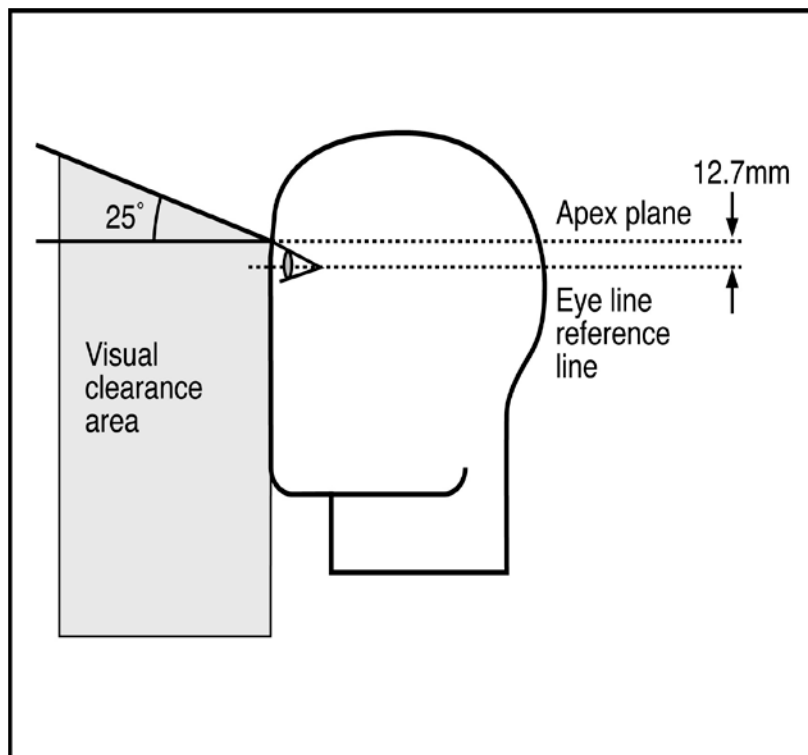

### 3.3.4 Ventilation

It is the manufacturer's responsibility to provide for adequate ventilation in the headgear design.

### 3.3.5 Retention System

The retention system should be attached so that the headgear remains in its normal position during play. The chin strap that secures the headgear should be affixed to both sides of the headgear and pass under the lower jaw in close proximity to the jaw and the neck. The minimum width of the chin strap shall be 15 mm. Buckles or similar hard fixings may not be used. Rubber buttons or Velcro® type fixing materials are acceptable.

## 3.4 Performance Requirements

### 3.4.1 Impact Attenuation

When tested in accordance with the procedures specified in Section 4.3, the peak acceleration of impacts delivered to test locations shall not be less than 200g.

### 3.4.2 Retention System Strength

When tested in accordance with Section 4.4, the strap should stay intact and closed when loaded with a 7 kg mass but should fail when strained dynamically by an additional mass of 10 kg allowed to fall through 300mm.

### 3.4.3 Retention System Effectiveness

When tested in accordance with the procedures specified in Section 4.5 the headgear may shift but not roll off the wearer's head when initially subject to a static load of 3 kg followed by an additional dynamic load exerted by a 4 kg load falling through 175mm.

## 4. Test Methods and Procedures – Headgear

### 4.1 Sampling

Three (3) test specimens of each size shall be submitted by Manufacturers, complete with 'Information supplied by the Manufacturers' (see section 9). Two specimens shall be used for impact attenuation testing at the various conditions and one for retention system testing.

### 4.2 Conditioning of Specimens

Prior to impact testing, one specimen will be exposed to ambient conditions and another to high temperature conditions as follows:

- (i) Ambient Temperature - one sample is conditioned by exposing it to a temperature of 20°C +/- 2°C and relative humidity condition of rh60% +/- 5% for a period of between 4 and 24 hours.
- (ii) High Temperature - the second is conditioned by exposing it to a temperature of 50°C +/- 2°C and relative humidity condition of rh60% +/- 5% for a period of between 4 and 24 hours.

All testing shall be conducted within 5 minutes of removal from the conditioning environment.

### 4.3 Impact Attenuation Testing

#### 4.3.1 Principle

The headgear is mounted on the test headform so that the headform can be oriented in different positions and dropped onto a flat impact surface. The acceleration and time history of the impact are recorded using a tri-axial accelerometer and appropriate instrumentation. Peak acceleration and time duration data obtained using the methods specified in Section 4.3.4 are used to determine the impact characteristics of the headgear.

#### 4.3.2 Apparatus

The apparatus for the impact attenuation test shall consist of the following (also see Figure 4):

**Headforms** – All headforms used will be to EN 960, be of metal and have a low resonance frequency (but not lower than 3kHz).

**Anvil** – the anvil shall consist of a flat steel surface of diameter 130mm +/-3mm and not have a resonance frequency liable to affect

measurements. The centre of mass of the drop head form shall lie over the centre of the anvil.

**Guide Assembly** – a headform shall be attached to a free fall or rail guided drop assembly carriage by an adjustable mounting or other means that will allow impacts to be delivered at any prescribed point on the headgear.

**Accelerometer** – a set of three accelerometers in a three axis array are mounted at or close to the centre of gravity of the test headform when the headform is mounted in the free fall carriage assembly.

**Impact Recording and Displaying Instrumentation** – the impact shall be recorded and displayed on a storage oscilloscope with specified deflection factors, sweep speed per division and bandwidth for each of the accelerometers and be capable of resolving the  $g_{max}$  of the headform. Equivalent instrumentation capable of recording, displaying and storing the impact signal from the accelerometers shall meet this requirement.

**Figure 4.**  
**Typical apparatus for Impact Testing of Headgear**

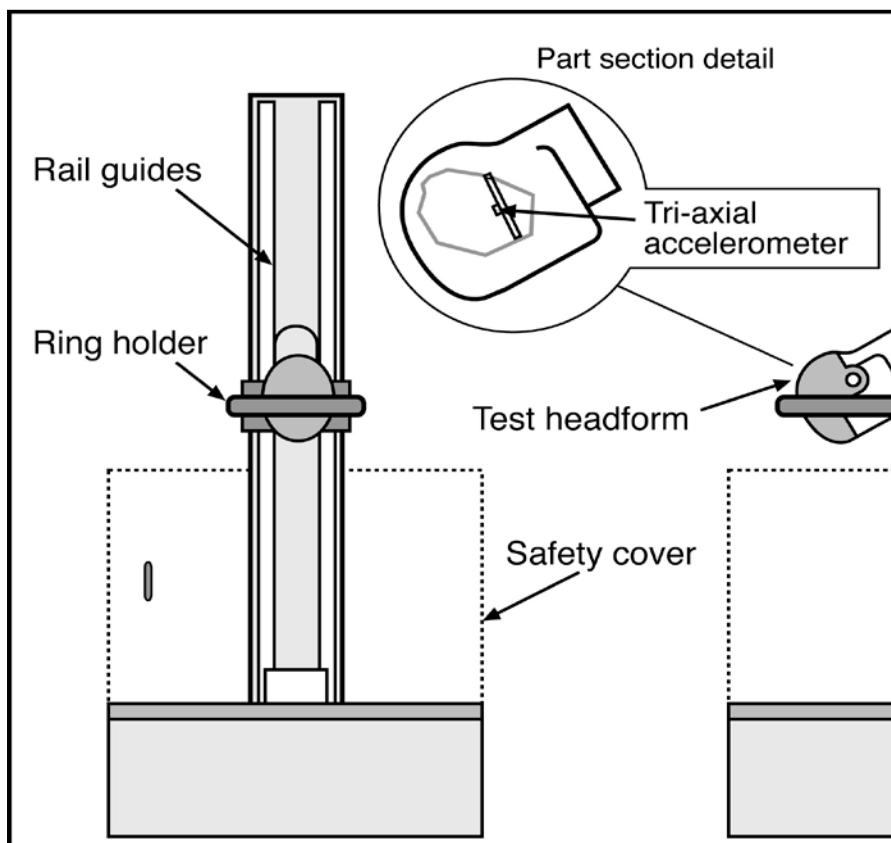

#### 4.3.3 Reference Testing

A flat MEP (modular elastomer programmer) reference surface will be used measuring 150mm diameter, 25mm thick mounted on a matching steel base. The headform will be dropped onto the MEP impact surface from a distance 300mm +/- 5mm. Resolved gmax values recorded by the accelerometer on three successive drops shall lie within +/- 10g of the mean.

#### 4.3.4 Impacting

The headgear is matched for best fit to the testform according to the manufacturers recommendations. Each headgear is impacted where additional padding has been applied within the specified zones of coverage (crown, forehead and temple/sweatband areas). An energy level of 13.8J will be used for impact. This is equivalent to the 'J' headform falling through 300mm. The height of fall will be adjusted for each headform mass.

Note: Mass of headforms used are

A - 500 mm - 3.1Kg ± 0.10

E - 540 mm - 4.1Kg ± 0.10

J - 570 mm - 4.7Kg ± 0.14

M - 600 mm - 5.6Kg ± 0.16

O - 620 mm - 6.1Kg ± 0.18

The impact zones will be:

Once, where crown padding is provided.

Twice where forehead padding is provided.

Twice where temple padding is provided.

**Figure 5.**  
**Impact locations on Headgear**

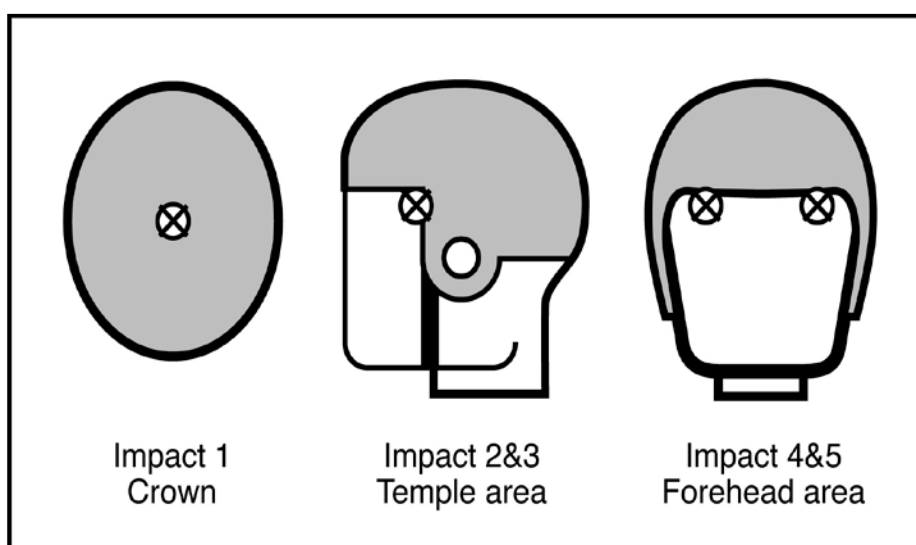

#### 4.3.5 Calculations

##### Maximum acceleration

The maximum peak acceleration is calculated by measuring the perpendicular distance to the trace baseline from the midpoint of the resultant trace at maximum excursion and multiplying by the sensitivity factor. The sensitivity factor is defined as g per division deflection of the trace.

#### 4.3.6 Duration of Impulse

Determine the duration of the pulse by measuring the total width of the trace along the 150g line in milliseconds.

### 4.4 Retention System Testing – Strength

#### 4.4.1 Principle

The chin strap of the headgear is subjected to two loads. The first a static load of 7 kg to which the strap will not open or break. The second is an additional load which falls dynamically to apply a sudden downward load causing the strap to open or break.

#### 4.4.2 Apparatus

A suitable set-up is shown in Figure 6. The headgear is positioned on a test headform (to EN 960 and without hair). A support is provided for the headform. A vertical guide assembly with anvil is attached below the headgear with two round pins of diameter 12mm and 76mm apart (between centres). The total mass of the guide assembly with anvil is 7 kg +/- 0.02 kg. A drop weight of 10 kg +/- 0.02 kg can be moved up the guide assembly and dropped onto the anvil in a substantially frictionless fall through a distance of 300 mm +/- 5 mm.



**Figure 6.**  
**Apparatus for Test of Retention System Strength**

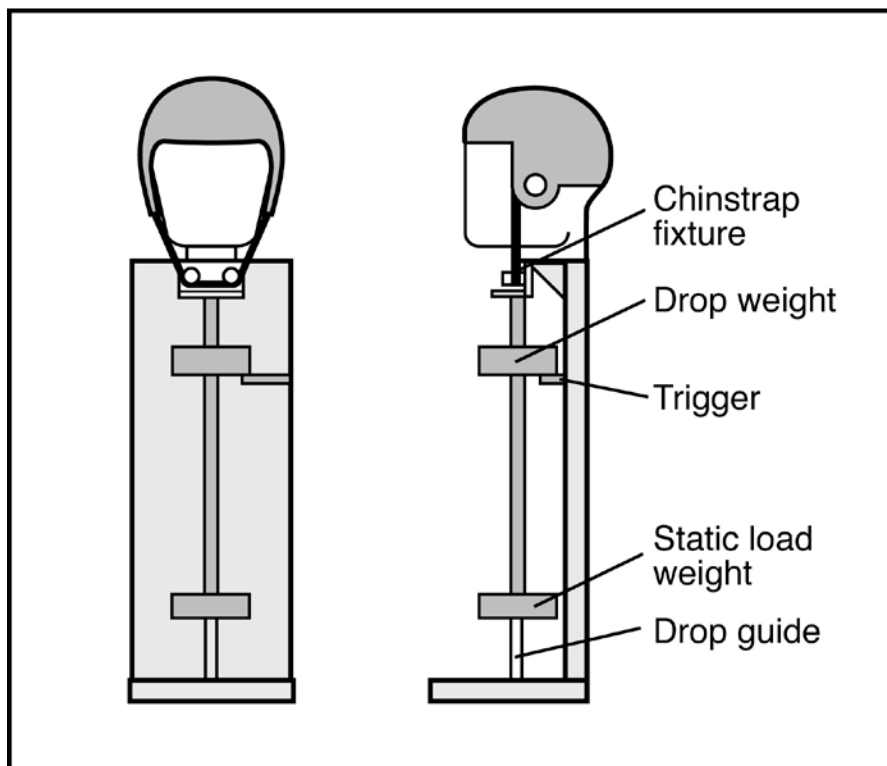

#### 4.4.3 Procedure

The headgear is mounted on the test headform and the retention system is adjusted so the headgear is securely positioned. The guide assembly is attached to the chin strap of the headgear. The mass falling through 300mm to the guide assembly anvil exerts a dynamic force under which the strap fails. If the strap fails under the static load, it will be deemed 'failed'. If the strap fails when additionally subjected to the dynamic load it will be deemed 'passed'. If the strap does not fail under both static and dynamic load it will be deemed 'failed'.

### 4.5 Retention System Testing – Effectiveness

#### 4.5.1 Principle

The headgear positioned on a headform is subjected to a tangential force at the rear edge of the headgear in a forward direction. The resulting shock places a rotational load on the headgear. The headgear may be shifted but must not roll off.

**Figure 7.**  
**Typical Apparatus for Retention System Effectiveness**

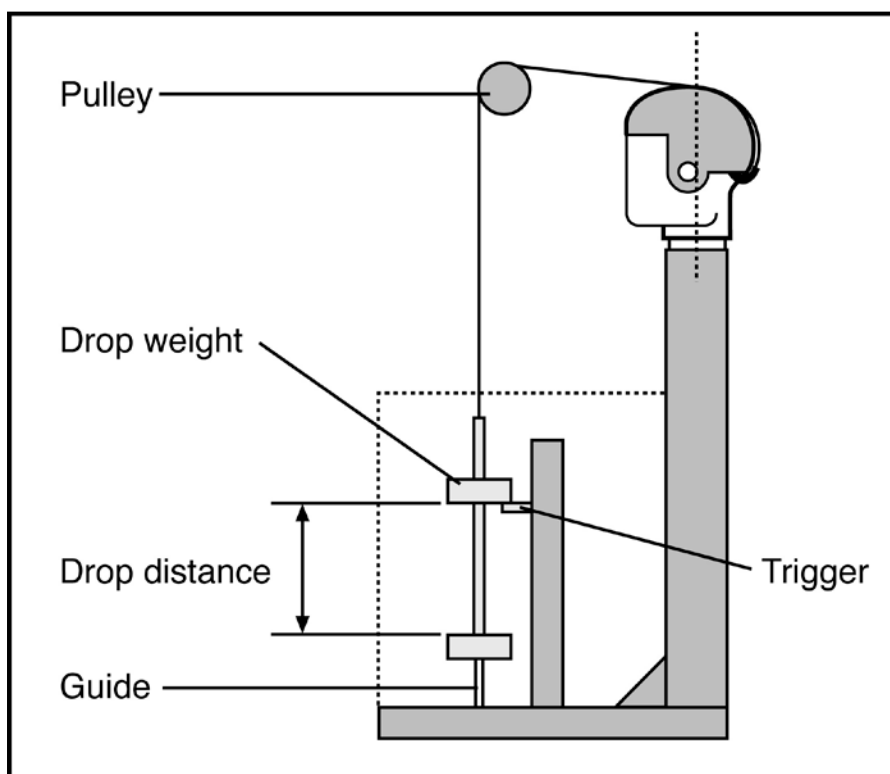

#### 4.5.2 Apparatus

A typical apparatus is shown in Figure 7. The headform (to EN 960 without hair) is mounted on a stand in the upright position. To this is fitted the headgear according to manufacturers instructions. A vertical guide assembly weighing 3 kg +/- 0.02 kg in total is attached via a cable or strapping\* to a hook which attaches to the rear of the headgear. A drop weight of 4 kg +/- 0.02 kg can be moved up the guide assembly and dropped onto the anvil in a substantially frictionless fall through a distance of 175 mm +/- 5 mm.

\*Note: The cable or strapping shall be of a material having an elongation of no more than 5mm per 300mm when loaded with a 22 kg weight in the free hanging position.

#### 4.5.3 Procedure

The headgear is mounted on the headform and the retention system adjusted so as to obtain the best fit. The hook is attached to the rear of the headgear to which is attached the guide assembly weighing 3 kg. The drop weight of 4 kg falls through 175mm +/- 5mm before it hits the anvil. The headgear may be shifted but must not roll off the headform. The retention system is readjusted and the test is repeated one more time. If the headgear rolls off, the test will be deemed a failure.

## 5. Requirements – Shoulder Padding

### 5.1 Ergonomics

Shoulder padding shall be designed and constructed so that all normal playing movements can be carried out without hindrance or discomfort.

### 5.2 Construction

#### 5.2.1 Materials

It is the manufacturer's responsibility that all materials used should not be adversely affected by water, dirt, perspiration, toiletries, household soaps and detergents. All materials coming into contact with the wearer's body will not be of the type known to cause skin disorders and shall not cause abrasion of either the wearer or other players.

#### 5.2.2 Padding Materials

Padding materials must be homogeneous (i.e. padding facing towards the wearer must be the same texture, hardness and density as that facing the opponent). Foam padding of sandwich construction is not allowed.

#### 5.2.3 Finish

All edges shall be smooth and rounded. There shall be no rigid projections on the inside or outside of the product that could harm the wearer or other players during normal use.

### 5.3 Design

#### 5.3.1 Zone of Coverage

Shoulder padding shall have a maximum zone of coverage about the sternoclavicular (SC-), acromioclavicular (AC-) and glenohumeral (GH-) joints.

**Figure 8.**  
**Shoulder Padding – Zone of Coverage**

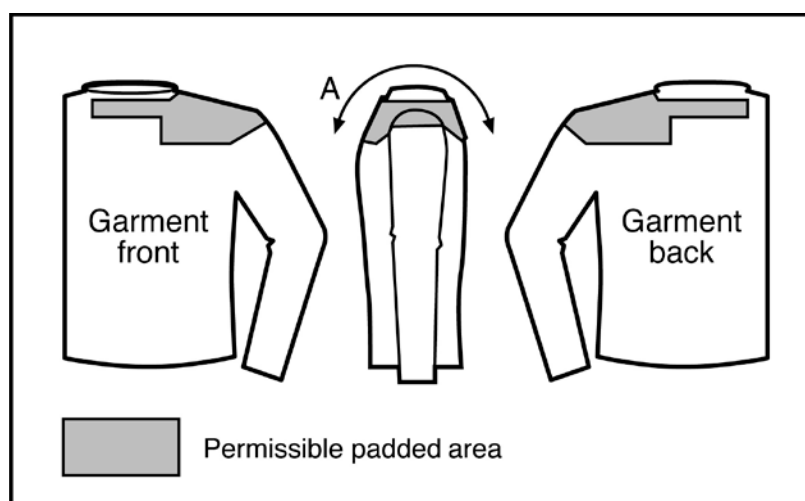

Shoulder padding will cover the shoulder and collar bone only and extend from the neck to a maximum of 2cm down the upper arm. An allowance for padding to cover the SC joint is made to a maximum depth of 60mm and at the back of the neck to a maximum depth of 70mm. The padding will have a maximum thickness of 10mm +2mm tolerance band plus an additional allowance of 1mm on each side for fabric. Figure 8 illustrates a garment providing this coverage. The shoulder padding shall have a maximum zone dimension 'A' given in Table 3. The padding shall fulfill the impact performance specification (Section 5.4). All padding materials must have a density not greater than 45 kg/m<sup>3</sup> + 15 kg/m<sup>3</sup> tolerance band. Areas outside the designated zones of coverage do not have to meet impact requirements but must comply with Regulation 12, Schedule 1, 4.4(g) – set out below:

**Table 3.**  
**Maximum Dimensions of the Zone of Coverage for Shoulder Padding**

Dimension	A (Max)
<i>Size</i>	<i>mm (in)</i>
<b>XS</b>	175 (7")
<b>S</b>	200 (8")
<b>M</b>	230 (9")
<b>L</b>	250 (10")
<b>XL</b>	300 (12")
<b>XXL</b>	350 (14")

#### 4.4(g) Banned items of clothing

A player must not wear any item of which any part is thicker than 0.5 cm when uncompressed or is denser than 45 kilograms per cubic metre unless specified within this Regulation 12/Law 4. Where this overall thickness consists of padded material covered by fabric, 0.5 cm is the maximum measured thickness for the combination of the uncompressed padding and the fabric. The fabric can contribute up to a maximum measured thickness of 1 mm on each side of the padding.

#### 5.3.2 Retention System

Shoulder protectors may be secured to the body by a tight fitting undergarment where the protectors are sewn in or may be inserted into compartments in the undergarment or jersey. Harness type retention systems can be used. The undergarment should be capable of being attached to the body using adhesive tape if necessary.

### 5.3.3 Sizing

Shoulder pads will be sized according to wearer's chest girth. Manufacturers may allocate their products to nominal sizes each of which covers a range of actual sizes (see Table 4).

**Table 4**  
**Chest Dimensions for Nominal Sizing**

	XS <i>cm</i> <i>(in)</i>	S <i>cm</i> <i>(in)</i>	M <i>cm</i> <i>(in)</i>	L <i>cm</i> <i>(in)</i>	XL <i>cm</i> <i>(in)</i>	XXL <i>cm</i> <i>(in)</i>
<b>Men's Chest</b>	91 (36)	96.5 (38)	102 (40)	107 (42)	112 (44)	117 (46)
<b>Women's Chest</b>	81 (32)	86 (34)	91 (36)	96.5 (38)	102 (40)	107 (42)

## 5.4 Performance Requirements

### 5.4.1 Impact Attenuation

When tested in accordance with the procedures specified in Section 6.3, the peak acceleration of impacts delivered to test locations shall not be less than 150g.

## 6. Test Methods and Procedures – Shoulder Padding

### 6.1 Sampling

Two (2) test specimens of one size (the larger size if possible) and one test specimen of all other sizes shall be submitted by manufacturers, complete with Product marking (clause 8) and Instructional literature (clause 9). Both specimens shall be used for impact attenuation testing at the various conditions.

### 6.2 Conditioning of Specimens

Prior to impact testing, one specimen will be exposed to ambient conditions and another to high temperature conditions as follows:

- (i) Ambient Temperature - one sample is conditioned by exposing it to a temperature of 20°C +/- 2°C temperature and a relative humidity of rh60% +/- 5% for a period of between 4 and 24 hours .
- (ii) High Temperature - the second is conditioned by exposing it to a temperature of 50°C +/- 2°C and a relative humidity of rh60% +/- 5% for a period of between 4 and 24 hours..

All testing shall be conducted within 5 minutes of removal from the conditioning environment.

## 6.3 Impact Attenuation Testing

### 6.3.1 Principle

The shoulder pad is mounted on a cylindrical test anvil. A mass with flat striking surface is dropped onto it. The peak acceleration and time history of the impact are recorded using an accelerometer and appropriate instrumentation. Peak acceleration and time duration data obtained using the methods specified in Section 6.3.4 are used to determine the impact characteristics of the shoulder pads.

### 6.3.2 Apparatus

The apparatus for the impact attenuation test shall consist of the following (also see Figure 9):

Drop Assembly - a dropping mass shall be attached to a free fall or rail guided drop assembly carriage. The mass shall be 5 kg +/- 0.02 kg. The dropping mass shall have a flat striking face of diameter 130mm +/- 2mm.

Anvil- the anvil shall consist of a horizontal steel cylinder with a diameter of 115mm +/- 2mm and shall not have a resonance frequency liable to affect measurements. The centre of mass of the drop mass shall lie over the centre of the anvil.

Accelerometer - an accelerometer is mounted at or close to the centre of gravity of the drop mass.

Impact Recording and Displaying Instrumentation - the impact shall be recorded and displayed on a storage oscilloscope with specified deflection factor, sweep speed per division and bandwidth for the accelerometer and be capable of resolving the g<sub>max</sub> of the drop weight. Equivalent instrumentation capable of recording, displaying and storing the impact signal from the accelerometer shall meet this requirement

### 6.3.3 Reference Testing

An MEP (modular elastomer programmer) reference surface with a convex face will be used, measuring 150mm diameter, 25mm thick at the centre and mounted on a matching steel base. The drop weight will be dropped onto the MEP impact surface from a distance 300 +/- 5mm. Resolved g<sub>max</sub> values recorded by the accelerometer on three successive drops shall lie within +/- 10g of the mean.

### 6.3.4 Impacting

Each shoulder pad is impacted at two locations providing the size of padding allows a distance of not less than 3cm apart and at least 2 cm from the periphery of the padding. Where size of shoulder pad does not allow this than a single location for each padding is permitted.

It is important that the maximum length of impact area is equivalent to the diameter of the drop weight striking surface. The impacting energy will be 14.7J (which is equivalent to a 5 kg drop weight falling through 300mm)

The time interval between each impact shall not be less than 30 seconds nor more than 2 minutes.

**Figure 9.**  
**Apparatus for Impact Testing of Shoulder Pads**

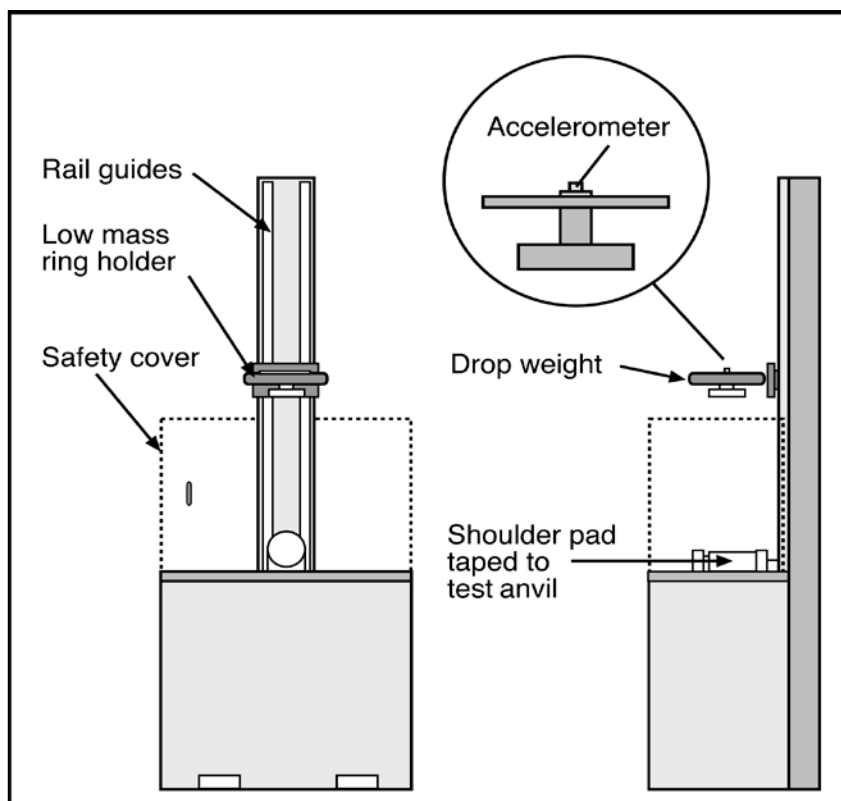

### 6.3.5 Calculations

#### Maximum acceleration

The peak acceleration is calculated by measuring the perpendicular distance to the trace baseline from the midpoint of the trace at maximum excursion and multiplying by the sensitivity factor. The sensitivity factor is defined as g per division deflection of the trace.

### 6.3.6 Duration of Impulse

Determine the duration of the pulse by measuring the total width of the trace along the 150g line in milliseconds.

## 7. Requirements – Breast Padding

### 7.1 Ergonomics

Breast padding is specific to female players and should be designed and constructed to minimise discomfort for the wearer. All normal playing movements shall not be impeded by wearing breast padding.

## 7.2 Construction

### 7.2.1 Materials

It is the manufacturer's responsibility that all materials used in the construction of breast padding should not be significantly affected by water, dirt, perspiration, toiletries, household soaps and detergents. All materials coming into contact with the wearer's body will not be of the type known to cause skin disorders and shall not cause abrasion of either the wearer or other players.

#### 7.2.1.1 Padding Materials

Padding materials must be homogeneous (i.e. material facing towards the wearer must be the same texture, hardness and density as that facing the opponent and not of sandwich construction). All padding materials must have a density not greater than  $45 \text{ kg/m}^3 + 15 \text{ kg/m}^3$  tolerance band.

#### 7.2.1.2 Semi Rigid Breast Cups

Where cups are part of the garment, it is important that these must be of a semi-rigid material and that this is limited to the front area about the nipple, as shown in Figure 10. The cups shall not exceed a perpendicular 4mm thickness from the front surface at any point.

### 7.2.2 Finish

Breast padding shall be so constructed that it is unlikely to cause any injury to the wearer or other players during play. There shall not be hard or sharp edges, seams, buckles or other items on the surface of the product that could harm the wearer or other players during normal use.

## 7.3 Design

### 7.3.1 Extent of Coverage

The extent of coverage shall include at least all the area shown in Figure 10 below.

### 7.3.2 Zones of Coverage

Breast padding shall have an area which covers the soft tissue and the axillary tail. Outline dimensions of the area of coverage shall be based on the under bust girth measurement with brassiere cup size or, bust girth measurement. The typical dimensions of the area of coverage are given in Table 5.



**Figure 10.**  
**Breast Padding – Zone of Coverage Outline**

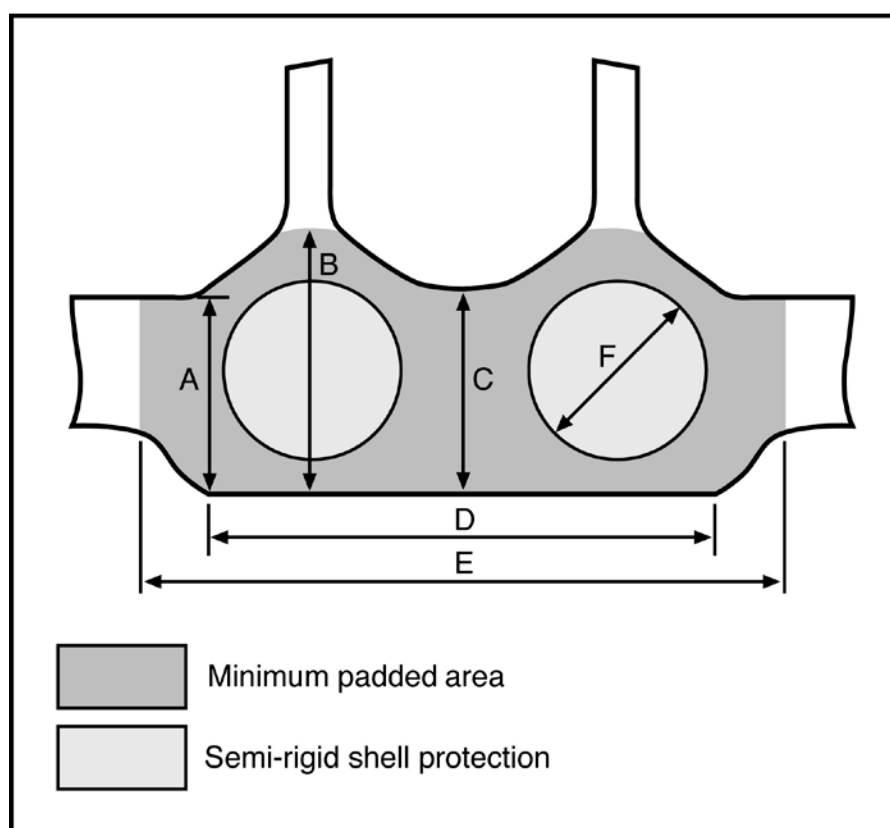

**Table 5.**  
**Typical Outline Dimensions for Breast Padding**

Size	Under Bust Girth <i>mm</i> <i>(inches)</i>	A	B	C	D	E
1	660 – 711 (26-28)	87 (3.43)	123 (4.84)	68 (2.68)	234 (9.21)	284 (11.20)
2	762 – 813 (30 - 32)	109 (4.29)	154 (6.05)	85 (3.35)	292 (11.51)	356 (14.00)
3	864 - 914 (34 - 36)	131 (5.15)	184 (7.26)	102 (4.02)	351 (13.8)	427 (16.80)
4	965 - 1016 (38 - 40)	152 (6.00)	215 (8.47)	119 (4.69)	410 (16.12)	498 (19.60)
5	1067 - 1118 (42 - 44)	174 (6.86)	246 (9.68)	136 (5.36)	468 (18.42)	596 (22.4)

Dimension F: The cups will correspond to internationally recognised brassiere cup sizes and may be inserted into the garment to suit.

7.3.3 Breast Padding with integral shoulder padding

Breast Padding with integral shoulder padding is allowed. The shoulder sections will be subject to the same constraints of design and testing as shoulder padding alone. Allowance is made for shoulder padding to meet breast padding at the front of the garment.

**Figure 11.**  
**Breast Padding with shoulder padding -**  
**Zone of Coverage Outline**

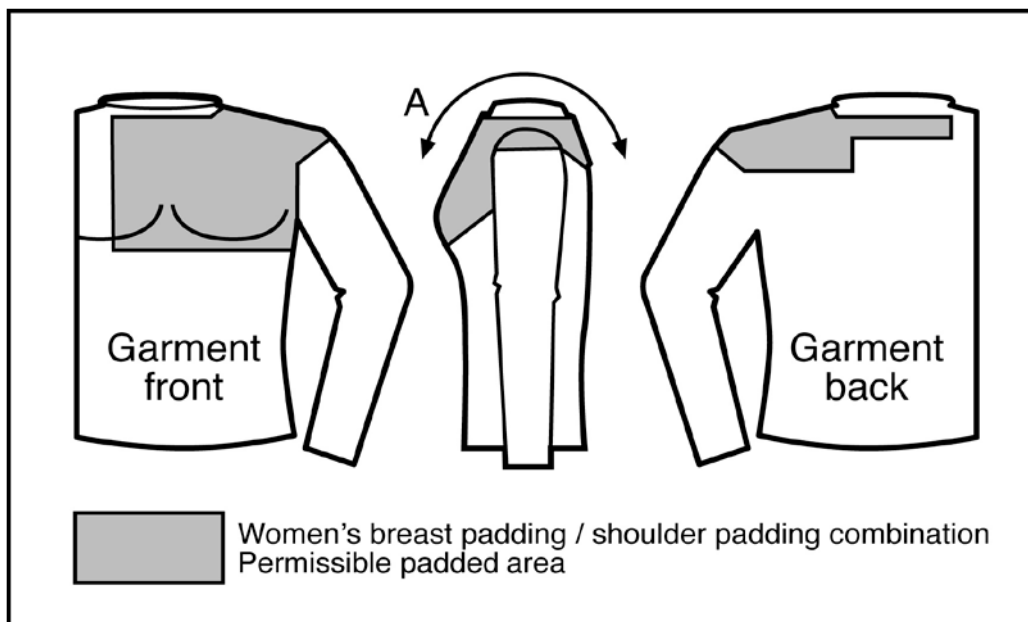

**8. Product Marking**

Padding equipment shall be permanently marked with the following information by the manufacturer:

- Name or trademark of the manufacturer.
- Size or size range for proper fit.
- Instructions on cleaning.
- Notification (once approval has been secured) that the clothing meets the minimum requirements of the World Rugby Standard.
- CE mark where garment is sold into the EC, it is the responsibility of the manufacture to comply with the PPE directive.

**9. Instructional Literature**

Padding equipment shall be accompanied by at least the following information:

- Instructions that describe proper fit and position.
- Instructions to replace after damage.
- Instructions on cleaning.
- Warning concerning improper use of cleaning agents, etc. or any other factors affecting the integrity of the equipment
- Notification (once approval has been secured) that the clothing meets the minimum requirements of the World Rugby Standard.
- Size or size range for proper fit.

## **SCHEDULE 2. SAFETY ASPECTS OF RUGBY BOOT SOLE DESIGN. GENERAL DESIGN GUIDANCE**

### **World Rugby REGULATIONS – LAW 4.3**

Studs/cleats of player's boots must conform with World Rugby Specifications (Regulation 12), must not be longer than 21 mm, and must not have any burring or sharp edges.

To refer to 'General Design Guidance' as follows:

### **GENERAL DESIGN GUIDANCE**

#### **GUIDANCE FOR SHOE AND STUD/CLEAT MANUFACTURERS**

##### **CONTENTS**

Risk assessment

General guidance

Performance Tests:

Test A – Skin Glancing/Raking test

Test B – Skin Stamping test

Test C – Stud/cleat Impact test

Test D – Fitting of replaceable studs/cleats

Test E – Wear simulation

### **RISK ASSESSMENT**

Three main injury mechanisms are prevalent during play:

- (a) Glancing
- (b) Raking
- (c) Stamping

In each case one or more studs/cleats on the boot sole may contact the other player depending on circumstances.

The worst-case scenario in any event will be when a single stud/cleat, normally one toward the edge of the sole, makes contact alone.

The main factors regarding individual stud/cleat design are: shape, profile, length, radius of edges, hardness, propensity to burring, and rate of wear (the latter being with respect to exposing other internal materials/components).

The design of studs/cleats needs to be considered in both plan and profile view, and also with respect to both contact area and radius of curvature. Contact area relates to contact pressure and hence the risk of bruising to, and penetration of, a player's skin. Radius or sharpness of edges relates to risk of cutting the skin.

In addition, there are whole sole design factors to consider including sole rigidity and edge profile.

Table 1 summarises many of the potential risk factors that should be considered - the list is not exhaustive.

Attention is also drawn to legislation such as the EU General Product Safety Directive (92/59/EEC), which applies to all products sold within the European Union. Equivalent or similar legislation may apply in other countries or regions of the world.

**Table 2.**  
**Risk Assessment of Rugby Boot Sole Design**  
**with respect to Injury to Other Players**

Design & Dimensions	Strength & Durability of Materials & Construction	Performance Tests	Labelling & User Instructions
<p><b>Assessment against geometric parameters.</b></p> <p><b>This approach can be used to assess conventional conical stud designs.</b></p> <p><b>For assessing other stud designs testing may be appropriate.</b></p>	<p>(1) Impact resistance with respect to risk of stud/cleat breakage.</p> <p>(2) Impact resistance with respect to risk of a stud/cleat detaching during play and leaving a dangerous protrusion or edge.</p> <p>(3) Risk of damage to studs/cleats resulting from the process of fixing and removing them (and/or (blanking plates) from the boot and that could introduce an injury risk.</p> <p>(4) Wear resistance with respect to risk of burring or exposing dangerous internal components</p>	<p>(1) Glancing skin injury – before and/or after real or simulated wear.</p> <p>(2) Raking – before and/or after real or simulated wear.</p> <p>(3) Stamping – before and/or after real or simulated wear.</p>	<p>Instructions on:</p> <p>(1) Attaching/removing studs/cleats, if appropriate.</p> <p>(2) Fixing blanking plates, if appropriate.</p> <p>(3) Care and maintenance respect to safety</p> <p>(4) Replacing studs/cleats at wear limit, if appropriate.</p> <p>Assess and report any other risks not covered by the above.</p>

## GENERAL GUIDANCE

The following guidelines provide guidance on the design, dimensions and performance of rugby studs/cleats. Suitable performance tests are suggested which can be used to evaluate the performance of new stud/cleat designs.

<p><b>Materials</b></p>	<p>Materials used in the studs/cleats should be such that they do not give rise to hazards as a result of mechanisms such as abrasion or impacts in wear; or through any other form of damage or deterioration. Materials used in replaceable studs/cleats should be capable of repeated fixing and removal without creating a hazard.</p> <p>Nylon has been found previously not to be a suitable material due to its propensity to burring.</p>
<p><b>Shape and Dimensions</b></p>	<p>Stud/cleat length shall be no greater than 21 mm (see Law 4).</p> <p>Studs/cleats complying with the design and dimensions shown in Figure 1 should give satisfactory performance.</p> <p>The shape and dimensions of other stud/cleat designs should be such that they present a no greater risk of injury to another player than the stud/cleat shown in figure 1. Tests A and B can be used to assess comparative performance.</p> <p>The plan view cross-sectional contact area of the stud/cleat shown in Figure 1 at a plane 2 mm below the tip is 78 mm<sup>2</sup>. Other studs/cleats having the same or greater contact area might be expected to give satisfactory performance dependent on minimum stud/cleat width in any direction.</p> <p>All edges of the studs/cleats should be finished smooth and rounded to a radius of not less than 1mm.</p>
<p><b>Construction and design</b></p>	<p>The edge profile of the sole unit itself should be rounded with no sharp edges.</p> <p>The studs/cleats should have no external projections on its surface except where text or a logo is desired. In such cases, the embossment details shall be no more than 0.3 mm proud of the surrounding material of the stud.</p> <p>The studs/cleats and their attachment should be capable of withstanding mechanical demands of service, including impacts and abrasive wear, without becoming damaged and creating a potential hazard. Performance can be assessed by means of tests C, D and E.</p> <p>In the case of studs/cleats incorporating a spigot or similar, it is recommended that:</p> <p>(a) when the attachment spigot is of a different material from the stud/cleat, a clearly visible warning should become evident when the stud/cleat has worn down to a length that gives a minimum of 2 mm cover to the end of the spigot.</p> <p>(b) Any flutes or other recesses for the fixing tool, should not extend nearer to the tip of the stud/cleat than the clearly visible warning mark.</p> <p>Replaceable studs/cleats should be designed in such a way that they can be fitted by a method that does not damage the stud/cleat and thereby introduce a cutting hazard or any other hazard.</p>

**Figure 1.**  
**Correct size of stud**

Acceptable dimensions for conical or cylindrical studs/cleats

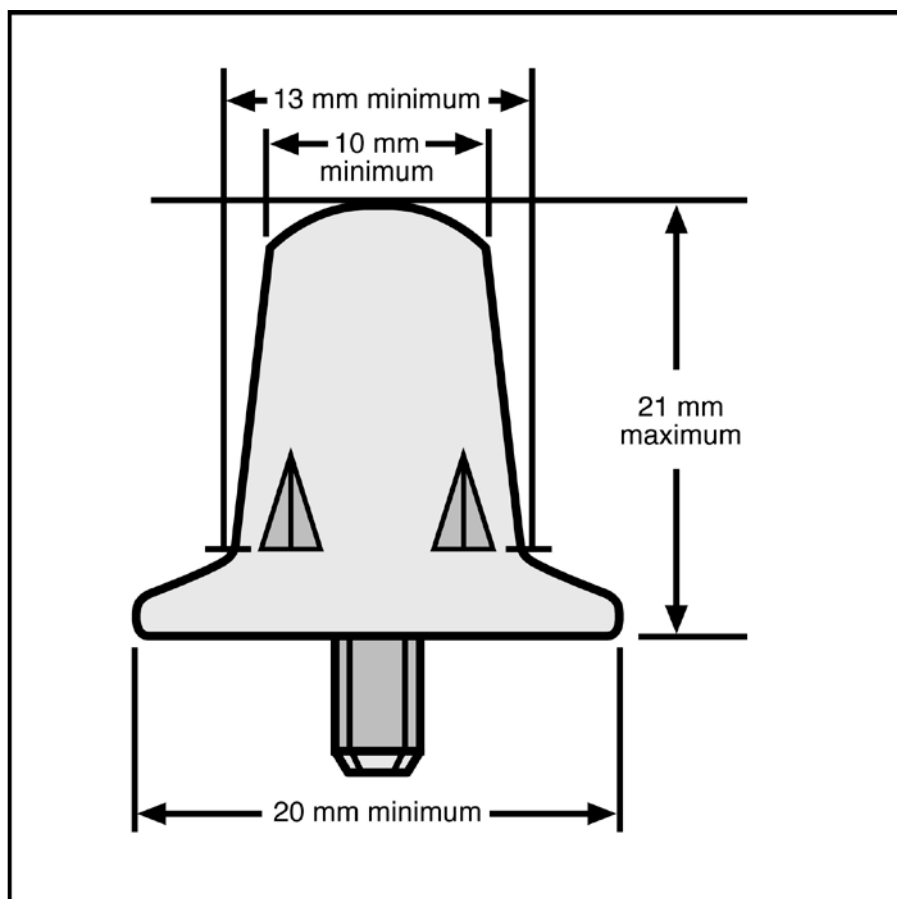

Also the minimum diameter values together with the maximum length value also defines a “comparator” stud/cleat, made in aluminium, that can be used in performance tests to evaluate alternatively shaped studs/cleats.

#### **PERFORMANCE TESTS – OPTIONAL**

The principles for five tests are suggested:

- Test A – Skin Glancing/Raking test
- Test B – Skin Stamping test
- Test C – Stud/cleat Impact test
- Test D – Fitting of replaceable studs/cleats
- Test E – Wear simulation

Tests A and B provide a direct method of assessing a stud/cleat’s propensity to cause injury through glancing, raking or stamping mechanisms.

Tests C and D assess the mechanical strength of studs/cleats and their attachment to the boot and thereby assess the risk of product failure resulting in a stud/cleat or boot sole becoming damaged and creating a potential hazard.

Test E provides a means of assessing how studs/cleats may change in-service due to wear and indicate whether or not there is an increased risk of injury.

A schematic illustration of the principle of each test is given below.

For tests A and B a suitable human flesh simulant is required comprising an artificial skin backed with a thick deformable muscle-like material. For example, a 1.5 mm thick poromeric shoe upper material having relatively low abrasion resistant may be used an artificial skin combined with gelatine, moulded into suitable form, as the deformable substrate.

The performance criterion for tests A and B is that the stud/cleat be evaluated should cause no greater damage to the artificial skin than the reference stud/cleat defined in Figure 1 above.

**Test A – Skin Glancing/Raking test**

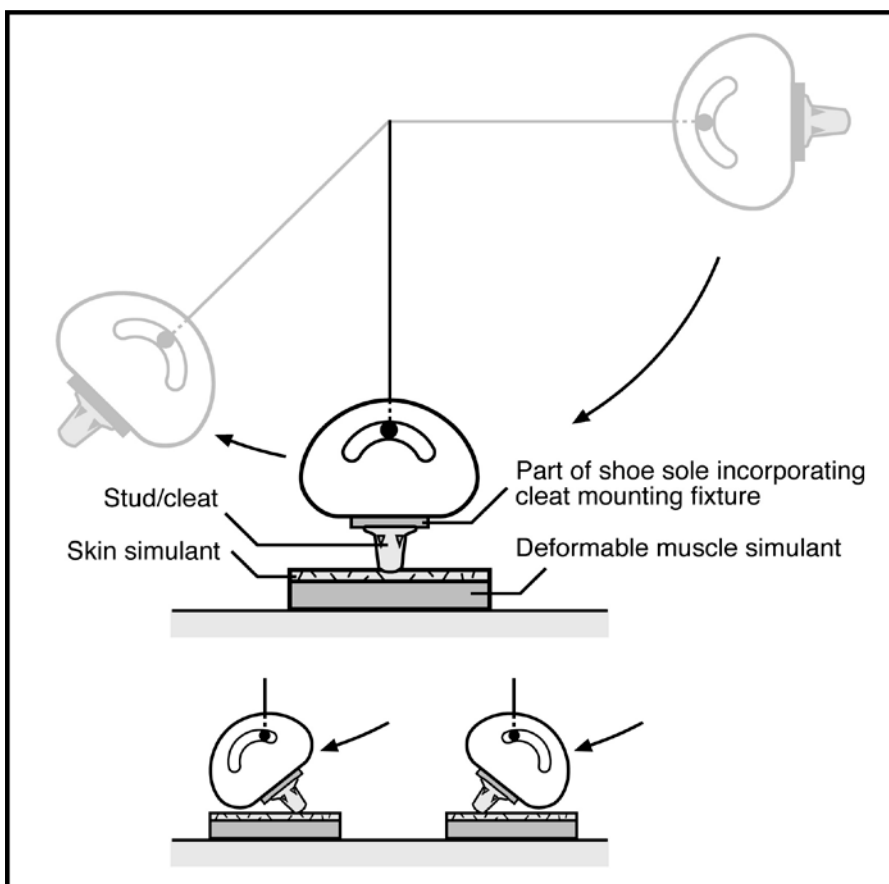

This test assesses the risk that a stud/cleat may cut or otherwise injure other players as it slides or rakes across the skin. A simulated skin surface is subjected to a series of glancing blows by the stud/cleat, which



is attached to the underside of a pendulum or equivalent device. In the test the tip, the flank and any integral mounting or fixture points come into contact with the simulated skin over a sliding distance of at least 70 mm (a pendulum device might require a spring loaded mechanism to achieve the sliding distance). The amount of damage to the simulated skin is compared with that inflicted by the comparator stud (Figure 1). In addition, the follow through swing of the pendulum can be recorded as the energy absorbed by the contact.

### Test B – Skin Stamping test

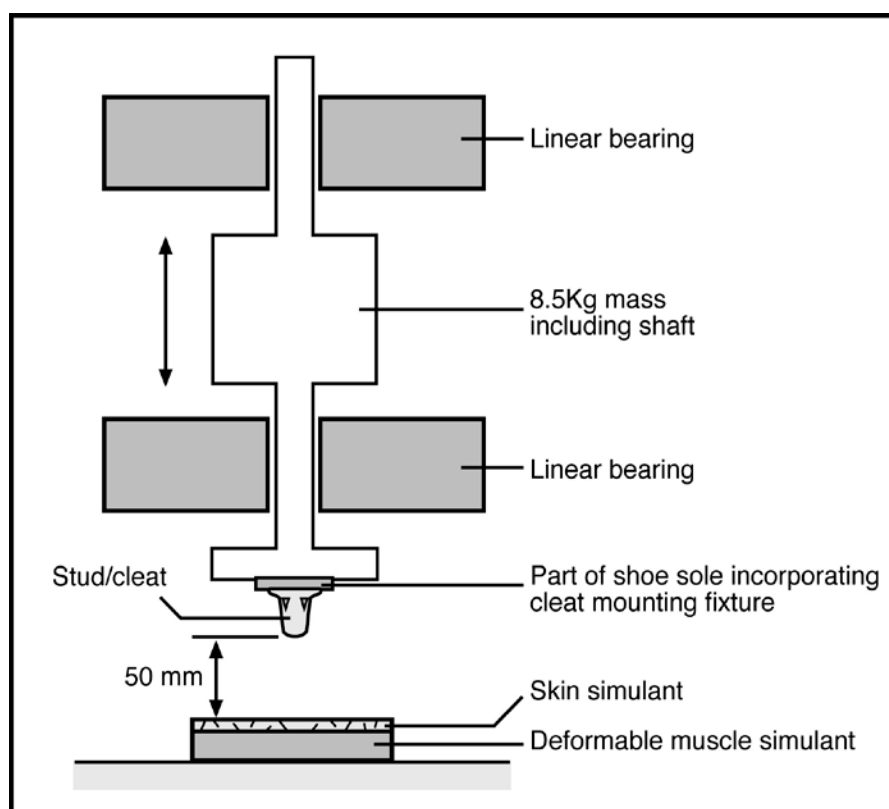

A falling weight impact test or equivalent means of replicating the impact forces at heel strike in running should be used. A mass of 8.5 kg dropped from a height of 50 mm would be a suitable approach.

The test rig should stand on a rigid, high mass base to eliminate energy losses through vibration.

The stud/cleat should be mounted securely by its base and including all parts of the mounting or fixing system, to either the moving or fixed part of the test in such a way that it impacts the skin/flesh stimulant (mounted on the other part) with the wearing face of the stud/cleat.

The depth of penetration of the stud/cleat into the artificial skin/tissue should be measured and compared with the value obtained with the comparator stud (Figure 1). Visual assessment of damage to the skin would also be made.

**Test C – Stud/cleat impact test**

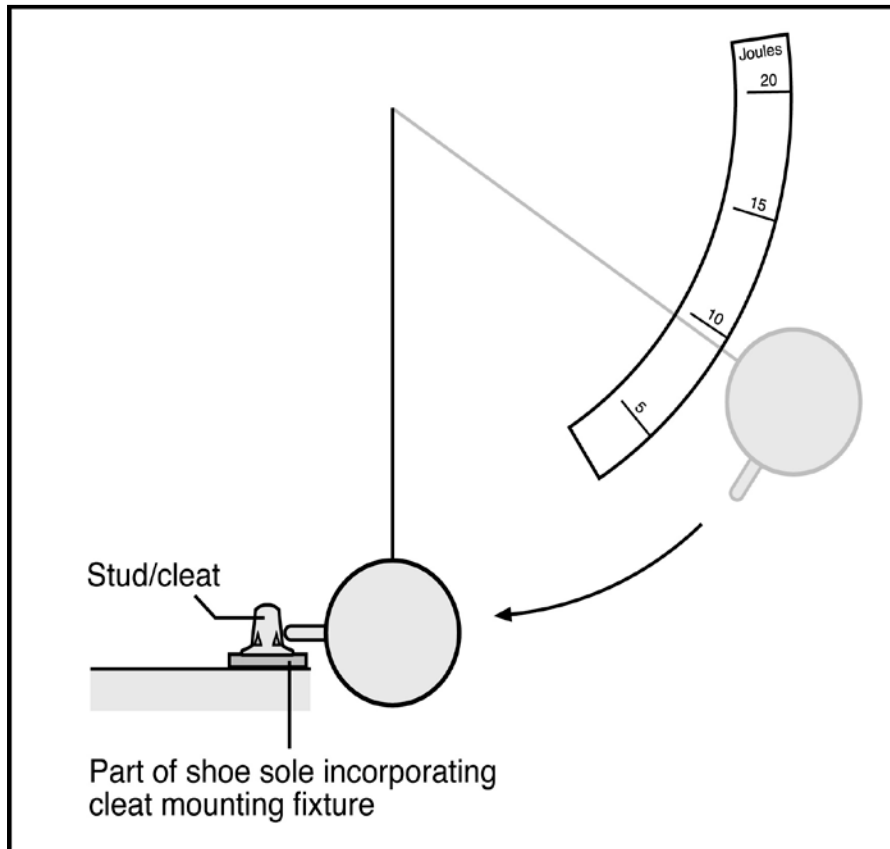

A stud/cleat, mounted securely by its base and including all parts of the mounting or fixing system, is subjected to a series of measured blows to its side from the striker of a ballistic pendulum or similar device. The energy of the blows is increased in steps until either the stud/cleat or its means of attachment fails or a specified energy level is reached without damage occurring.

It is suggested that when tested up to and including an impact energy of 8 J the stud/cleat tested shall:

- (a) remain secured to the attachment system;
- (b) not disintegrate or completely split;
- (c) not show any fracture

If the impact of 8 J causes fine hairline splits or cracks, the test should be continued in steps of 0.5 J. The stud should remain secured to the attachment system and not disintegrate or completely split at impacts up to 12 J.

### Test D – Fitting of replaceable studs/cleats

If the stud/cleat is replaceable then it should be fixed to, and detach from, the boot sole at least ten times according to the manufacturer's instructions and using the tools provided, if any. Apply a torque or force level just over and above what might be considered 'reasonable' for a powerful rugby player. For example, a reasonable torque to apply to conventional screw-in studs is 1.5 N.m.

Inspect for any sign of damage that might increase the risk of causing injury in wear. Where such damage occurs, tests could be carried out according to tests A and B.

### Test E – Wear simulation

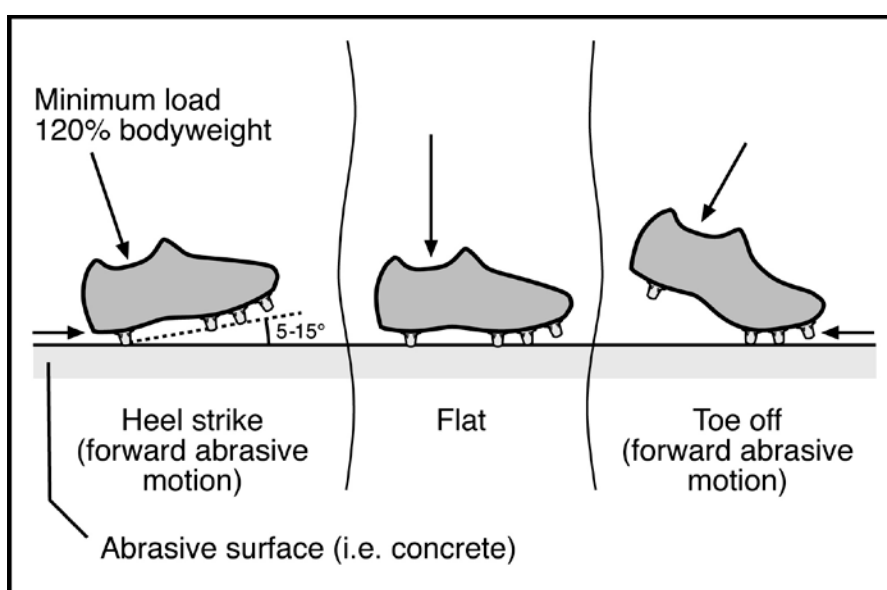

The principle of this test should be based on replicating the biomechanics of gait such that it reproduces the correct contact angles and loads between the boot and ground that occur in wear. The test cycle commences with the heel striking the test floor at a predetermined angle, and the vertical load increasing as the 'leg' rolls forward over the shoe-ground contact point, eventually transferring contact to the forepart of the shoe and finally toe-off. The vertical load achieved during the cycle should be at least 120% bodyweight. The floor used should replicate an abrasive, man-made surface such as concrete or asphalt that might be expected to be found around rugby pitches or in clubhouses.

Alternatively simple trials, whereby players walk or run for say 400 m on an abrasive, man-made surface, would suffice.

Inspect each stud/cleat for any sign of damage that might increase the risk of causing injury in wear. Where such damage occurs, tests could be carried out according to tests A and B.

## **SCHEDULE 3. WORLD RUGBY PERFORMANCE SPECIFICATIONS FOR PLAYERS MONITORING DEVICE**

### **Introduction**

Rugby is a contact sport with intrinsic hazards. Player Monitoring Devices are worn by Players to determine various parameters of performance during matches. This Specification identifies mandatory requirements for Player Monitoring Devices without seeking to compromise the form or appeal of the game and with the overall goal being to promote player welfare and reduce the risks of injuries to Players as far as practicable.

### **1. Scope**

This Specification sets out requirements for Player Monitoring Devices. General requirements relating to the ergonomics, construction, sizing and design of the equipment are specified. Performance requirements relating to impact attenuation and retention method are also provided, and the corresponding test methods are described.

### **2. Terminology**

- Player Monitoring Device (Device) – any Device which is worn by a Player and which is capable of determining, live or recorded, data about a Player's movements or any physical aspect of their performance.
- Retention System – that which is used to secure the Device to the body.
- Radius of curvature – the radius of a circle formed with the curved part of a Device's surface when looking at a cross-sectional view perpendicular to the top surface.
- Rupture – damage to the Device as defined in Section 4.3.1
- Stud – a steel stud as per that defined in Regulation 12 – Schedule 2, Figure 1.
- $g$  – the acceleration due to gravity.  $g$  (standard) = 9.80665 m/s<sup>2</sup>.

### **3. Requirements**

#### **3.1 Ergonomics**

Devices must be designed and constructed to minimise discomfort for the wearer. Normal playing movements shall not be impeded by wearing the Device.

## 3.2 Construction

### 3.2.1 Construction Materials

It is the manufacturer's responsibility that all materials used in the construction of the casing of the Device shall not be significantly or materially affected by ultra-violet radiation, water, dirt, perspiration, toiletries, household soaps and detergents. All materials coming into contact with the wearer's body will not be of the type known to cause skin disorders and shall not cause abrasion of either the wearer or other Players.

### 3.2.2 Retention System

Devices must be secured to a Player's person via one of two methods:

- A pouch incorporated into the rear of the Player's jersey; or
- A pouch incorporated into a harness to be worn by the Player under the jersey, which complies fully with all relevant requirements of Law 4 and Regulation 12.

Whichever of those methods is used to retain the Device must ensure that the Device is held broadly in line with the Player's T2 – T6 vertebrae, with its longest dimension parallel with the Player's spine. The pouch must be small enough to ensure that the Device cannot rotate on any axis while worn by the Player.

Both methods must incorporate a padding material surrounding all sides of the Device which does not exceed 2mm thickness.

Padding materials must be homogeneous padding facing towards the wearer and must be the same texture, hardness and density as that facing the opponent). Foam padding of sandwich construction is not allowed.

### 3.2.3 Finish

Devices shall be so constructed that they will not cause any injury to the wearer or other Players during play.

## 3.3 Size, Weight and Shape

Devices must be within the maximum and minimum dimensions detailed in Table 1 below:

Dimension	Maximum	Minimum
Length	100 mm	60 mm
Width	50 mm	30 mm
Thickness	25 mm	10 mm

*Table 1: Dimension requirements for Player Monitoring Device*

No surface of the Device may have a radius of curvature less than 12mm. This does not apply to:

- Markings, where the depth of any profile does not exceed 1mm.
- Any surface which has a radius of curvature less than 12mm must have a tangent that is less than or equal to 30° from the normal where the normal is perpendicular to the Player's back when worn in the manner prescribed by the manufacturer. See Figure 1 below.

In addition, the following openings are permitted:

- Openings for fixings must not be greater than the equivalent area of a circle with a diameter of 5.5mm.
- Openings for connectors (charging points, etc.) must not be greater than 100mm<sup>2</sup>

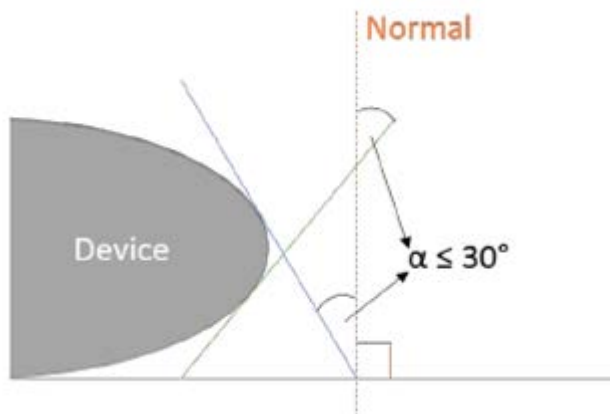

*Figure 1: Radius of curvature*

The mass of the Device shall not exceed 0.09 kg, including the weight of any battery devices within it.

### 3.4 Performance Requirements

#### 3.4.1 Resistance to Impact Loading

When tested in accordance with the procedures specified in Section 4.4.5, the Device shall not rupture by any manner detailed in Section 4.3.1.

### 3.4.2 Resistance to Compression Loading

When tested in accordance with the procedures specified in Section 4.4.6 the Device shall be deemed to have failed if it ruptures under loads less than 1.001kN. If a Device ruptures under loads of between 1kN and 2.5kN, then it must be assessed for failure as detailed in Section 4.3.2. If the Device does not rupture under a load of 2.5kN then the Device will be deemed to have passed the dynamic loading requirements.

If, at any point a Device fails a testing requirement, the whole testing protocol must be stopped and the Device design determined to be non-compliant.

## 4. Test Methods and Procedures

### Compliance

#### 4.1 Sampling

Two distinct test pieces are required:

- Empty Device casings
- Full Devices, that is a Device which includes all parts required to function properly and as intended to be worn by an athlete.

A total of 20 empty Device casings and 5 full Devices are required for testing.

It is recommended that all empty Devices are tested for all conditions prior to the full Devices being tested.

#### 4.2 Conditioning of Specimens

- Test specimens must be in a new, un-used and un-tested condition.
- The test specimen must be prepared by being conditioned for 12 hours at  $0\pm 2^{\circ}\text{C}$  or  $23\pm 2^{\circ}\text{C}$  depending on the test requirements and at an ambient humidity.

#### 4.3 Testing Conditions

##### 4.3.1 Rupture

A Device will be deemed to have ruptured if the casing changes shape permanently as a result of any of the modes:

- Fractures – When the surface of the Device cracks or fractures resulting in any part protruding beyond the level of the original (pre-test) surface.
- Shatters – When one or more fragments are detached from the body of a Device into one or multiple small, sharp pieces.

- Undergoes plastic deformation – When the form of a component is permanently altered. The form will not have changed if the original features as measured for Section 3.3 are met while disregarding any punctures (holes made by the stud penetrating the device).

4.3.2 Impact Loading failure

A Device will be deemed to have failed the impact loading test if it ruptures (as defined in 4.3.1 above).

4.3.3 Compression Loading failure

A Device will be deemed to have failed the compression loading test if it shatters (as defined in 4.3.1 above) or any sharp, jagged edges, including those of internal parts of the full Devices tested, protrude from the surface of the Device.

4.4 Test locations

The Device is tested at points within two areas (Area 1 and Area 2) where the product is deemed to be most prone to fracture. The points chosen within these areas are tested repeatedly and are determined by the tester from specifications detailed in Section 7 which lead the tester to determine them as the structurally weakest points.

The two areas are produced from the centre point of the product, when viewing it in plan-view as it would be secured to a Player's back (pursuant to paragraph 3.2.2 above). This is determined by finding the midpoint of the topmost face from the length and width of the Device. When the midpoint has been determined, Area 1 is calculated to 50%  $\pm$ 1% of the full height and 75%  $\pm$ 1% of the full width from the centre point. Area 2 is defined as the largest elliptical area which can be created where no edge overlaps the edge of the Device. The area encompassed by Area 1 is not included in Area 2, so that the two locations cannot both be located within area 1.

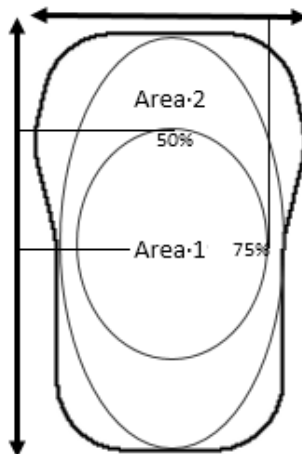

Figure 2: Test Location Areas



#### 4.4.5 Impact Load Testing

##### 4.4.5.1 Principle

The Device is impacted with a metal stud and assessed for damage.

##### 4.4.5.2 Apparatus

The following apparatus is required:

- A method of reducing the temperature of the sample to  $0^{\circ}\text{C} \pm 0.1^{\circ}\text{C}$ .
- A humidity gauge capable of recording to  $\pm 1\%$  humidity.
- A thermometer or thermocouple capable of recording temperatures at  $0.1^{\circ}\text{C}$  increments
- A camera capable of producing a digital record of all features pre and post testing.
- Double-sided adhesive tape  $10 \times 30 \pm 1$  mm with a thickness of  $0.15 \pm 0.1$  mm and an adhesive strength of at least  $15 \pm 5$  N/cm to steel shall be used to secure the Device to the steel plate.
- Distance measuring Device capable of measuring to 0.1mm increments
- A stud, as defined in Section 2 above, which is free from visual defects.
- A test machine which includes:
  - A test area that allows the Device to be laid horizontally across a steel plate of a minimum thickness of 10mm. There must be a clear surround on the plate of 15mm in all directions when the sample is mounted.
  - A steel frame capable of dropping a mass of  $6.2\text{kg} \pm 0.050\text{kg}$  vertically on guide rails from various heights between 0mm and 150mm from the top of the fixed sample. Care must be taken to ensure the friction between the mass and the guide rails is kept to a minimum (free slide). The guide rails must be frictionless or as close to frictionless as possible. This should be verified by measuring the free drop acceleration which must be within 5% of the theoretical acceleration due to gravity.
  - A means of securely connecting the stud to the mass in a manner which ensures that it is the only item striking the Device.

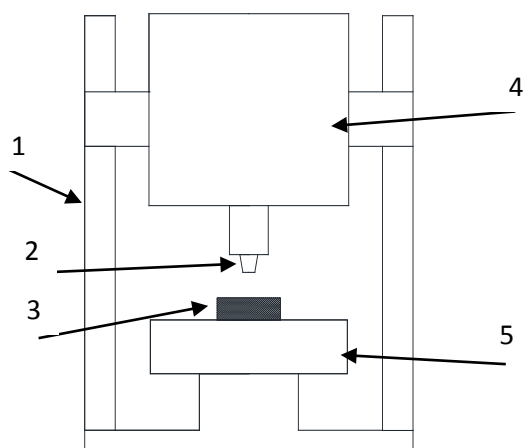

*Figure 3: Impact Load Testing Apparatus:  
1. Guide rails 2. Stud 3. Test Specimen  
4. Drop Mass 5. Steel base plate*

#### 4.4.5.3 Procedure

- The stud is fitted onto the drop mass in order to make contact with the Device.
- Adhesive tape is applied between the base plate and the GPS unit as stated in 4.4.5.2 above.
- The maximum dimensions of each Device along all 3 axes are measured accurately and recorded.
- The Device is positioned so that the stud impacts the appropriate identified test location stated in Section 4.4. The impact of the stud and drop mass shall not dislodge the Device from its position when impacting otherwise the results obtained should be discarded.
- The impact assembly (weight and stud) is positioned to drop from a distance of  $30 \pm 0.2 \text{mm}$  between the top surface of the test specimen and the bottom surface of the stud. Table 2 details the testing schedule (each test must be conducted using a virgin test specimen).
- The impact assembly is released to drop through free fall so that the stud impacts the Device at the required location.
- The Device is assessed for failure as per the specification in Section 4.3 above.
- The maximum dimensions of each Devices along all 3 axes are measured accurately post-test and recorded.
- Full Devices (tests 9 and 10) shall only be tested if and when all other Devices are deemed to have passed the test.

Test	Position	Temperature (°C)
1 – 2	1	23±2 °C
3 – 4	2	23±2 °C
5 – 6	1	0±2 °C
7 – 8	2	0±2 °C
9 (Full Device)	1	23±2 °C
10 (Full Device)	2	0±2 °C

*Table 2 - Testing Schedule for Impact Testing*

#### 4.4.6 Compression Load Testing

##### 4.4.6.1 Principle

The Device is exposed to an increasing compression load until it ruptures or the applied load reaches 2.5kN.

##### 4.4.6.2 Apparatus

- A freezer to reduce the temperature of the sample to 0±0.1°C.
- A humidity gauge capable of recording to ±1% humidity.
- A thermometer or thermocouple capable of recording temperatures at 0.1°C increments.
- A camera capable of producing a digital record of all features pre and post testing.
- Double-sided adhesive tape 10x30 ±1 mm with a thickness of 0.15 ±0.1 mm and an adhesive strength of at least 15 ±5N/cm to steel shall be used to secure the Device to the steel plate.
- Distance measuring device capable of measuring to 0.1mm increments
- A stud, as defined in Section 2 above, which is free from visual defects.
- A test machine such that:
  - The specimen can be laid horizontally across a steel plate of a minimum thickness of 10mm with a minimum of 15mm free space around the specimen.
  - The load can be applied vertically at a constant rate of 10 ± 0.5mm/min.
  - A load up to 2.5kN can be applied to the Device.
  - The force applied to the test specimen can be read with a maximum error of 1% and can be recorded.
- Load applicators can be attached as per two testing conditions:

- A stud securely connected to the underside of the moving plate in a manner which ensures it is the only part of the moving plate which contacts the Device.
- Plate testing – A steel plate with minimum dimensions of 15mm larger than the test specimen in all horizontal directions and a minimum thickness of 10mm.

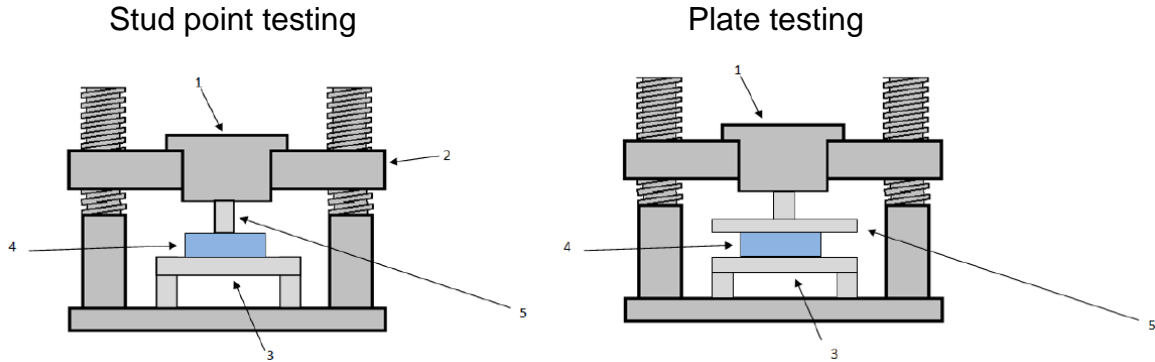

Figure 4 – Compression Test Apparatus:  
 1. Load Cell 2. Moving Crosshead 3. Steel Plate  
 4. Test Specimen 5. Load Applicator

4.4.6.3 Procedure

- Ensure the steel plate and load applicator are free of debris.
- Rest the Device on the steel plate with the identified test location directly below the appropriate load applicator as shown in Figure 4 securing with the double-sided adhesive tape between the test specimen and the steel plate.
- Vertically apply the load on the test specimen by means of the specified test machine at 10mm/min until the maximum load of 2.5kN is reached, utilising the appropriate load applicator for the test being conducted (plate or stud).
- Plot the resulting Force/Extension curve.
- Photographic images must be taken as per Section 5.1 below.
- For the 0°C testing conditions the testing must be commenced on a rising thermometer and testing must be completed before the Device temperature rises to 5.1°C.
- Full Devices shall only be tested if and when all other Devices are deemed to have passed the test.

Test	Impactor	Temperature (°C)
11 - 12	Stud	23±2 °C
13 – 14	Plate	23±2 °C
15 – 16	Stud	0±2 °C
17 – 18	Plate	0±2 °C
19 (Full Device)	Stud	23±2 °C
20 Full Device)	Plate	0±2 °C

Table 3 - Testing Schedule for Compression Testing

#### 4.4.7 Radius of Curvature

##### 4.4.7.1 Principle

The external form of the Device is checked to ensure all parts required have a radius of curvature greater than 12mm, and thus no sharp edges.

##### 4.4.7.2 Apparatus

An appropriate radius gauge, made of metal (steel or aluminium) and not more than 2mm thick shall be used. The shape of the gauge is shown in Figure 5, where  $r$  shall be  $12\text{mm} \pm 0.1\text{mm}$  and  $\alpha$  shall be  $60^\circ \pm 2^\circ$ .

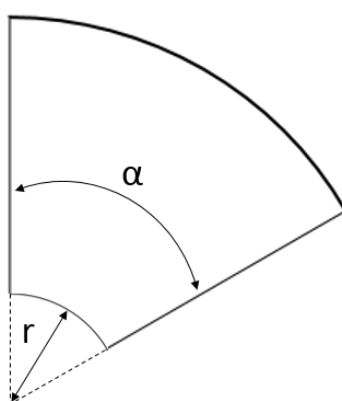

Figure 5: Radius Gauge

##### 4.4.7.3 Procedure

For all profiles of depth greater than  $1\text{mm} \pm 0.1\text{mm}$  place the gauge in the areas of minimum radius of curvature of the area to be tested. If both ends of the gauge touch the surface of the Device then that area passes the requirement. Figure 6 illustrates the procedure and the pass and fail conditions.

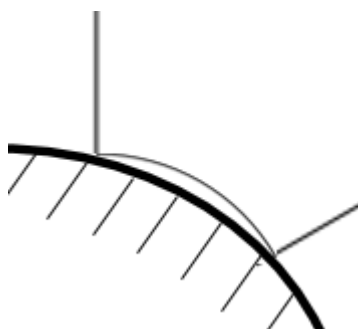
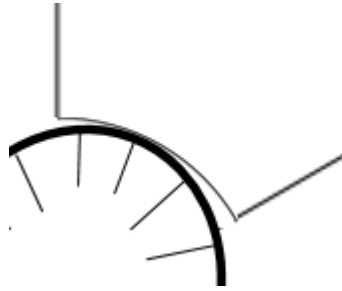

Figure 6 (a): Pass Condition



*Figure 6(b): Fail Condition*

## **5. Reporting**

### **5.1 Images**

Photographic images of each Device prior to and post testing are taken. Images must be on a plain background and well lit. Sufficient images must be taken of the Device including at least a plan, elevation, end elevation, and detailed views of any failure that occurs.

In addition, any data whether in table or graph form recorded during testing shall be reported.

### **5.2 Test Report**

The test results and all other required information shall be reported using the World Rugby Player Monitoring Device Testing Report.

## **6. Product Marking**

Devices shall be permanently marked with the following information by the manufacturer once compliance with this specification has been achieved:

- Name or trademark of the manufacturer.
- The World Rugby Approved logo, permanently visible on the Device.
- Any other markings required by any applicable regulations in the territory of use.

## **7. Manufacturer's declarations**

When submitting Devices for testing to testing institute, the manufacturer must provide a schematic of the Device design, including dimensions, with plan views of both sides of all assembly components for the casing and cross-sectional views along the length and width of the assembled casing.

## REGULATION 13. BROADCASTING RIGHTS

- 13.1** The promotion of safe, fair and orderly enjoyment of rugby is fundamental to the mission of World Rugby and its Unions and Associations. The Broadcasting of a well organised and regulated Game, the manner in which the Broadcasting is carried out, and the way Matches are scheduled and organised are critical to the development of the Game at grass-roots level, to the generation of support for teams at all levels, and to the public's interest in and enjoyment of the Game, and so to its success. It allows the Game, and the manner in which it is governed, structured and promoted, to be experienced more fully by a wider group of people, increasing the extent and intensity of involvement in all capacities and at all levels. The sale of Broadcasting Rights by rights owners is central to the generation of revenue for reinvestment in the Game and must be encouraged, though scheduling and commercial considerations must also be balanced against Player welfare, the efficient organisation of Matches and competitions and the interests of Unions, Rugby Bodies, Clubs and the public. It is consequently necessary that the broadcast of any Matches, played within the territory of a Union should be subject to the consent of that Union, and that Unions should be empowered to grant that consent subject to any terms and conditions deemed necessary in the interests of the Game.
- 13.2** For the purpose of this Regulation, Broadcasting means the transmission and/or recording and/or otherwise storing of coverage of or other reproduction of a Match or Matches in any medium and any use or exploitation of the same by any means in any electronic media now known or at any time in the future developed, including, but not limited to, all forms of television (which will include, without limitation, all forms of analogue, digital, free, pay, pay-per view and on-demand systems) and all other audio-visual media (which will include, without limitation, video, DVD, CD-Rom and/or other audio-visual recorded viewing medium) and all forms of interactive and/or on-line transmissions via the Internet or any other system, radio and all other audio only media (which will include all forms of recording and/or interactive and/or on-line audio transmissions via the Internet or any other system) whether live or deferred and whether in whole or in part throughout the world or any part thereof; and Broadcasting Rights means any right or entitlement or ability to do any of those things.
- 13.3** No Rugby Body, Club or Person or any combination thereof may negotiate or enter into or benefit from any grant or other conferral, whether by contract or otherwise, of any Broadcasting Rights in respect of any Match or Matches except with the express written consent of the Union within whose territorial jurisdiction such Match is or Matches are to be played. In deciding whether to grant such consent, and on what terms, the Union will act reasonably and proportionately, balancing appropriately the interests of all, including the public, the Game, Players and Clubs, and the Union, Rugby Body, Club or Person seeking such consent.

- 13.4** No Rugby Body, Club (or Person with knowledge of such breach) may take part in any Match to which Broadcasting Rights have been granted in breach of the provisions of Regulation 13.3.



**REGULATION 14. OWNERSHIP OF CLUBS**

- 14.1** No individual, body corporate, partnership, trust or any other entity (“Entity”) may directly or indirectly own or control more than one Club except with the prior written consent of the Union concerned, or where Clubs from different Unions are involved, the written consent of the Unions concerned and World Rugby.
- 14.2** An Entity will be deemed to be indirectly owning or controlling a Club if:
- 14.2.1** it owns or controls an Entity which directly or indirectly owns or controls a Club (irrespective of the number of Entities interposed between the two);  
or
- 14.2.2** pursuant to an agreement or understanding (whether formal or informal) an Entity co-operates with another to obtain or secure control of a Club;  
or
- 14.2.3** a connected person of an Entity owns or controls a Club. The term “connected person” is to be construed widely, but will include the following (which is a non-exhaustive list);
- (a) In the case of an individual, that individual’s wife, husband or other relative.
  - (b) Any Entities involved together in a trust, whether as trustee, settler or beneficiary.
  - (c) Any Entity involved in partnership together (in any business) with the entity which owns or controls a Club.
  - (d) A company is connected with another company if it holds any interest in the shares of that other company or the same Entity or any person connected to that Entity has control of both companies.
  - (e) A company is connected with another person if that person is an officer, employee or shareholder with 5 per cent, or more, of the Authorised Share Capital of the company or is connected to an officer, employee or such shareholder of the company.
  - (f) Any two or more persons acting together to secure or exercise control of a Club shall be treated as being connected with one another.
- 14.2.4** For the purpose of this Regulation 14, indirect ownership or control shall be widely construed.
- 14.3** For the purpose of this Regulation 14, “control” means the ability of an Entity, by whatever means, to secure that the affairs of a Club are or could be conducted or influenced in accordance with that Entity’s wishes.
- 14.4** For the purpose of this Regulation 14, “ownership” includes (without limitation) the holding of any number or class of shares in a company which owns the assets of a Club where those shares entitle the holder to

participate in more than 50% of any dividend declared (in the relevant class if applicable) or to more than 50% of the company's assets on a winding up.

- 14.5** This Regulation 14 shall be interpreted broadly to give effect to the underlying intention that no Entity or group of Entities, acting alone or in concert, shall control, or be in a position to control, either directly or indirectly, more than one Club.
- 14.6** Subject to obtaining the consent of the Union concerned or World Rugby, as provided for in Regulation 14.1, this Regulation 14 shall not prohibit the temporary ownership of more than one Club which arises out of the bona fide merger of two or more Clubs, provided that the ownership of more than one Club does not extend beyond three months.

## REGULATION 15. INTERNATIONAL MATCHES

### 15.1 Numbering players

For International Matches, Players should be numbered from left to right as follows:

Loose head prop	1	Scrum half	9
Hooker	2	Fly half	10
Tight head prop	3	Left wing	11
Left lock	4	Left centre	12
Right lock	5	Right centre	13
Left flanker	6	Right wing	14
Right flanker	7	Full back	15
Number eight	8		

Replacements/substitutes as in 15.1.1 below.

15.1.1 In any International Match two specialist front row Players are required to be selected by each Union as replacements/substitutes. These replacement Front Row Players shall be numbered 16 and 17. The other replacements/substitutes must be numbered from 18 to 23 with Forwards numbered before Backs.

- (a) Replacement/substitute Forwards (including 16 and 17) shall appear in order from Front Row to Number Eight.
- (b) Replacement/substitute Backs shall appear in order from Scrum half to Full back.

15.1.2 Without limiting the effect of Regulation 9.16, 72 hours prior to the kick-off of an International Match the Participating Unions must announce and exchange a list of the 15 Players who will start the Match and up to 8 replacements/substitutes.

### 15.2 Replacements and Substitutes in Matches in which a National Representative Team is playing

15.2.1 (a) Not more than 8 Players are to be available under Law 3 as replacements or substitutes. The Players nominated as replacements or substitutes may be changed into kit ready to play, but they must be seated in the stand (where available) or in some other suitable designated area within the playing enclosure, but not on the touch- line. Replacements or substitutes shall not enter the playing area until permitted to do so by a Match Official.

- (b) the medical practitioner appointed under Law 3, is to be the nominated Match doctor of the visited Union in attendance at the Match. He should be seated as near as practicable to the Players' entrance from the field-of-play.
- (c) If a Player sustains a bleeding or open wound ("blood injury") the Player must leave the playing area. The Match doctor shall determine whether a player has a blood injury that requires the Player to leave the field for treatment. If so the Player shall remain off the field until such time as the bleeding has been controlled, the wound covered or dressed and in the opinion of the Match doctor the Player is able to resume playing provided it is within the time period prescribed within Law 3. For the avoidance of doubt a player that has left the playing area with a blood injury shall not be entitled to resume playing if he does not return to the playing area within the time prescribed in Law 3.
- (d) If the nominated Match doctor gives his opinion that a Player should not continue playing on account of his injury, (whether such injury is a blood injury or otherwise) that Player shall not be allowed to resume playing. The opinion of the nominated Match doctor shall be conveyed to the Player's Union or its representative and it is then for that Union to decide whether or not a replacement shall be introduced.
- (e) A nominated representative of the Union, known to the referee, should stand on the touch-line with the replacement or substitute Player and signify that the replacement or substitute Player is ready to come on the field of play.

### **15.3 Match Day Doctor**

- 15.3.1 In respect of all International Matches, a Match Day Doctor shall be appointed by the Host Union. The role of the Match Day Doctor is set out in the World Rugby Match Day Doctor Manual available at [www.worldrugby.org/playerwelfare](http://www.worldrugby.org/playerwelfare). The Match Day Doctor Manual may be amended from time to time in accordance with best practice.

### **15.4 Match Officials**

- 15.4.1 Match Officials shall be selected for International Matches in accordance with the guidelines or procedures adopted by Council from time to time.
- 15.4.2 A coach and/or other representative(s) of a Union must not make any contact (whether in person or by technological, non-verbal or other means) with any Match Official(s) for an International Match on the day of the International Match save as permitted by Regulation 15.4.3 below.
- 15.4.3 A coach and/or other representative(s) of a Union is permitted to:
- (a) speak to a Match Official(s) in person on the day of an International Match in relation to matters not relating to the Match;

- (b) ask a Match Official(s) a question(s) in and/or nearby to the Union's changing room at such time as, and in the event that, the Match Official visits the Union's changing room on the day of the International Match; and
- (c) ask a Match Official(s) a question(s) at another time and/or location provided that the question(s) and the time and location have been pre-approved by the relevant Match Official manager, who may also attend at his election;

provided that at all times the World Rugby Code of Conduct is observed.

### **15.5 Postponement of an International Match**

- 15.5.1 After full consultation with the visiting Union, the visited Union shall have the sole right and discretion to determine whether or not an International Match shall be postponed on account of adverse weather conditions or the state of the ground.
- 15.5.2 Travelling and hotel expenses incurred by the visiting Union in connection with any such futile visit shall be paid by the visited Union.

### **Tours Agreement**

- 15.6 International Tours between Tier One Unions during the Global Release Periods specified in Regulation 9 shall be subject to the provisions of the Tier One Rugby World Tours Agreement (the "Tours Agreement").
- 15.7 The integrity and organisational efficiency of an International Tour is undermined in the absence of clear and binding terms and conditions that set out the duties and obligations of the Host Union and the Visiting Union and/or if the conclusion and signing of the Tours Agreement is delayed.
- 15.8 Unions have a responsibility to ensure that International Tour arrangements, Match location(s) and kick-off times are agreed and communicated at the earliest opportunity so that other stakeholders including supporters, broadcasters and other commercial partners may plan accordingly.
- 15.9 It is therefore a condition of World Rugby approval of any International Tour governed by the Tours Agreement that the Unions concerned comply with the provisions of the conditions for the finalisation, signing and implementation of the Tours Agreement ("Finalisation Conditions").

### **Finalisation conditions**

- 15.10 The purpose of the Tours Agreement and the establishment of Finalisation Conditions is to harmonise the basis on which Tours take place and to improve the efficiency of the manner in which the Agreement is finalised between Unions.

- 15.11** It is recognised that Unions need a degree of flexibility in structuring their tour arrangements, however this flexibility must not undermine the certain organisational and regulatory terms and conditions that apply to the International Tour.
- 15.12** The Tours Agreement is intended to be specific enough to achieve complete harmonisation of issues where uniformity is required yet general enough in other areas to permit flexibility on how other relevant touring issues may be implemented.
- 15.13** Unions that are scheduled to host an International Tour or participate as a Visiting Union in an International Tour shall, as soon as reasonably practicable following approval of the International Tour by Council, discuss and agree the arrangements that will be in place for the Tour and which shall be included in the Tours Agreement. Both the Visiting Union and Host Union shall consult on the applicable arrangements with a view to reaching consensus and agreement on all issues. The Tours Agreement must be finalised and signed as soon as reasonably practicable. In any event:
- (a) Match Venues for the Tour must be confirmed to World Rugby and notified to the Visiting Union preferably nine months, but no later than six months, prior to the commencement of the Tour and may not be changed without the prior approval of the Visiting Union, such approval not to be unreasonably withheld; and
  - (b) the Tour Agreement must be concluded and signed by both Unions via authorised signatories at least six weeks prior to the commencement of the International Tour.
- 15.14** If the Tours Agreement is not finalised within eight weeks of the commencement of the Tour then the Host Union must notify the CEO. The CEO shall be entitled to resolve any outstanding issue(s) subject always to those provisions of the Tours Agreement which shall be binding on the Host Union and Visiting Union in any event.
- 15.15** On receipt of notification pursuant to Regulation 15.14, the CEO (or his designee) shall be entitled to adopt such procedures as he considers appropriate and to receive what evidence and/or information he requires, however each Union shall be given the opportunity to set out its position. Each Union shall provide such assistance and information and/or documentation as the CEO (or his designee) may require. The CEO's decision(s) shall be final and binding on notification to the Unions and shall be implemented immediately by the relevant Unions.

#### **Solidarity, Best versus Best**

- 15.16** It is a fundamental imperative of the Game that the integrity and high standards of International Rugby Matches and International Tours are maintained. High quality International Rugby is in the best interests of the sport at all levels as it promotes the sport, maintains the integrity and solidarity of the game and its competitive dynamic. It encourages new

participants and respects the interests of the public and all Rugby stakeholders. In the best interests of the sport at all levels Unions will adopt selection principles and criteria that support the Best versus Best policy and act in good faith in this regard.

#### **CEO dispute resolution in relation to the Tours Agreement**

- 15.17** For disputes arising under Clauses 5.5, 20.2, 22.9, 22.16, 23.7 (and/or where the CEO otherwise agrees to deal with the matter pursuant to Clause 25.3(a)) the CEO (or his designee) shall on receipt of notification of the dispute issue and/or alleged breach determine the procedures that he wishes to adopt to resolve the matter. The CEO (or his designee) shall have full discretion in relation to such procedures and what evidence and/or information he requires. However each Union shall be given the opportunity to set out its position and each Union shall provide such assistance and information and/or documentation as the CEO (or his designee) may require. The CEO (or his designee) shall make a decision as soon as reasonably practicable. Such decision shall be final and binding on notification to the Unions and implemented immediately by the relevant Union(s).

#### **Team kit**

- 15.18** At least three (3) months prior to the commencement of an International Tour Unions shall exchange Team kit colours and agree if there is any clash of Team kits. If a clash exists between the proposed Team kits, the CEO of World Rugby or his nominee will seek to resolve the matter. However, in the event of a clash of kits, in the absence of any agreement to the contrary, the Host Union shall be entitled to wear its home kit.





---

**REGULATION 16. ORGANISATION OF INTERNATIONAL MATCHES;  
INTERNATIONAL TOURNAMENTS;  
INTERNATIONAL TOURS**

- 16.1** (a) All International Matches, International Tournaments, International Tours or Series of Matches involving the senior National Representative Team (at fifteen and seven-a-side) or the next senior National Representative Team of a High Performance Union(s)<sup>1</sup> must be regulated, co-ordinated and approved by the Council. No International Match, International Tournament, International Tour or Series of Matches involving the senior National Representative Team and/or next senior National Representative Team of a High Performance Union(s) can be confirmed before it has been approved by the Council, such consent not to be unreasonably withheld. The criteria for the approval of International Matches, International Tours, International Tournaments or Series of Matches involving the senior National Representative Team or the next senior National Representative Team of a High Performance Union(s) by the Council shall be determined by the Council from time to time.
- (b) All International Matches, International Tournaments, International Tours or Series of Matches involving the senior National Representative Team (at fifteen and seven-a-side) of Unions which are not High Performance Unions must be regulated, co-ordinated and approved by the CEO. No International Match, International Tournament, International Tour or Series of Matches involving the senior National Representative Team of Unions which are not High Performance Unions can be confirmed before it has been approved by the CEO, such consent not to be unreasonably withheld. The criteria for the approval of International Matches, International Tours, International Tournaments or Series of Matches which do not involve the senior National Representative Team of High Performance Union(s) by the CEO shall be determined by the CEO from time to time.
- (c) All International Matches, International Tournaments, International Tours and Series of Matches including age-grade and other forms of the Game save for fifteen and seven-a-side which do not fall within (a) or (b) above must be regulated, co-ordinated and approved by the Unions concerned and the Association in which the International Match, International Tournament, International Tour or Series of Matches is scheduled to be held. No such International Match, International Tournament, International Tour or Series of Matches can be confirmed before it has been approved by the Unions involved and the relevant Association, such consent not to be unreasonably withheld. The criteria for the approval of such International Matches, International Tours, International Tournaments or Series of Matches shall be determined by the

---

<sup>1</sup> "High Performance Union" means any of the twenty Unions which competed in the most recent Rugby World Cup.

relevant Unions and Associations from time to time in accordance with any directions of World Rugby.

16.1.1 The Council will establish a schedule of International Matches, an International Tournament schedule and an International Tour schedule for the High Performance Unions for an agreed period. Once International Match, International Tournament and International Tour details are confirmed by the Unions concerned and have been approved by the Council or, as applicable, the CEO or relevant Association, the arrangements cannot be changed unless agreed by the Council or, as applicable, the CEO or relevant Association.

16.1.2 International Matches, International Tournaments, International Tours or Series of Matches involving National Representative Teams may be provisionally arranged by the Unions concerned and subsequently submitted to the Council or, as applicable, the CEO or relevant Association (in accordance with Regulation 16.1(a), (b) or (c)) for approval at the discretion of the Council or, as applicable, the CEO or relevant Association. No International Match, International Tour, International Tournament or Series of Matches involving a National Representative Team(s) may be arranged by any organisation other than the Council or, as applicable, the CEO or relevant Association, and the Unions of such National Representative Teams in accordance with Regulation 16.1(a), (b) or (c).

## **16.2 Matches, tours and tournaments below National Representative level**

16.2.1 A Rugby Body or Club shall not play a Match or Matches against any Rugby Body or Club or other team(s) that are not affiliated (temporarily or otherwise) to a Union or against teams that contain Players that are not members of a Union without the prior written consent of the CEO (subject to Regulation 16.2.5 below).

16.2.2 When consideration is being given to a Match, Series of Matches or tour involving teams below National Representative level (e.g. Provincial, State, County, District, Club or other Rugby Body) from more than one Union, written permission to arrange such Matches or tours must first be obtained from the Secretary of the organiser's Union, who in turn, subject to permission being granted by his Union, will seek the agreement of the secretary of the other Union.

16.2.3 No Match, tour, or Series of Matches below National Representative level (e.g. Provincial, State, County, District, Club or other Rugby Body) shall be arranged or permitted to take place between teams from different Unions or one Union without the prior written agreement of the secretary of each of the Unions or Union concerned and the secretary of the Union within whose territory such Match, tour or Series of Matches is due to take place.

16.2.4 The visited Union shall be fully responsible for ensuring the proper administration and control of Matches or tours.

- 16.2.5 For the avoidance of doubt, the instigation, negotiation or arrangement of a Match, Series of Matches, tournament or tour to the country of another Union involving a “composite” or “scratch” team or any team which includes a Player who is (temporarily or otherwise) a member of a Union is prohibited unless the specific written permission has been granted by the Unions concerned, as applicable, and:
- (a) if the “composite” or “scratch” team includes a Contract Player(s) contracted to play the Game within a High Performance Union; the CEO; or
  - (b) if the “composite” or “scratch” team does not include any Contract Player set out in (a) above and/or otherwise in relation to a Player who is not (temporarily or otherwise) a member of a Union, the Association in which the Match is scheduled to be held.
- If both (a) and (b) above apply to a Match, Series of Matches, tournament or tour to the country of another Union, the CEO may grant permission in respect of both (a) and (b).
- 16.2.6 For the purposes of Regulation 16.2.5 a “composite” or “scratch” team is one which is neither:
- (a) a Club team; nor
  - (b) a National Representative Team or the team of a Rugby Body.
- 16.2.7 When any tournament is planned where it is proposed that teams below National Representative level, from two or more Unions will participate, the approval of the Unions concerned must be obtained in writing in advance through the Secretaries of those Unions.
- 16.2.8 Any Match, Series of Matches, tour or tournament which does not fully comply with the requirements of the Bye-Laws, Regulations and Laws of the Game shall be deemed unofficial. The Union within whose territory such an unofficial event takes place (and the visiting Union or Unions) and/or the Union or Unions of participating Provincial, County, District, Clubs or Rugby Bodies will be held responsible and will be liable to sanction in accordance with the Regulations and/or Bye-Laws.
- 16.3** Where a Match, Series of Matches, tour or tournament is approved by a Union or Association in accordance with Regulation 16, the Union or Association shall maintain a full record of such approvals which World Rugby may request from time to time.
- 16.4** Where a Match, Series of Matches, tour or tournament is approved in accordance with Regulation 16 to take place within the territory not of a Union but:
- (a) within the territory of a union in membership of an Association; or

(b) within the territory of a union within the jurisdiction of but not yet in membership of an Association with the consent of that Association;

the Association shall assume the relevant role and obligations of the Union set out in Regulation 16.

**REGULATION 17. DISCIPLINE - FOUL PLAY****Preamble**

- A** The underlying rationale for Regulation 17 is to maintain and promote fair play, protect the health and welfare of Players, ensure that acts of Foul Play are dealt with expeditiously and appropriately by independent means within the Game and that the image and reputation of the Game is not adversely affected.
- B** This Regulation sets out a harmonised approach to the administration of discipline and the implementation of sanctions for Foul Play at all levels of the Game. The objective of this Regulation is to achieve consistency in the way in which discipline is administered and uniformity in the manner in which the assessment of the seriousness of Foul Play is conducted and sanctions imposed. Underlying the Regulation is the overall objective that the disciplinary process shall comply with the fundamental principles of natural justice.
- C** This Regulation is drafted from the stand point of the international governing body of the Game. In recognition of the pyramid structure of international sport, the application and enforcement of this Regulation by Unions within their respective jurisdictions may necessitate suitable adjustments to cater for the imperatives of their competitions and domestic structures and as applicable to accord with national legislation.
- D** All participants in the Game shall by means of their participation recognise and agree to be bound by this Regulation including the core principle of universality which means that Players who are suspended at any level of the Game shall have their suspension recognised and applied at all levels of the Game and in the territories of all Unions and Associations. World Rugby has identified certain Core Principles which must be implemented by all Unions and Associations at all levels of the Game in the implementation of disciplinary rules for Foul Play.

**17.1 Core Principles**

- 17.1.1** The principles set out below shall be the “Core Principles” which shall be mandatorily applied in disciplinary regulations at all levels of the Game are as follows:
- (a) The sanctions applicable to Foul Play shall be the same throughout the Game. Therefore all Unions and Associations shall adopt the World Rugby Sanctions for Offences within the Playing Enclosure (Appendix 1) and ensure that they are applied within their territory. Where a Union adopts the World Rugby Disciplinary Guidelines for the Underage Game (Appendix 3), then the sanctions applicable to Foul Play Adjusted for Underage Rugby shall apply.
  - (b) All Matches are equal. A Player suspended from playing the Game shall be suspended from participating in any Match at any level during the period of his suspension.

- (c) The core sanctioning process set out in Regulation 17.19 shall be applied to all disciplinary cases involving Foul Play at all levels of the Game.
- (d) The principles of natural justice shall be adhered to in all disciplinary proceedings. Such principles include, Players cited/Ordered Off shall have the right to know the evidence against them, shall have the right to be heard, to be represented, to produce evidence and defend themselves before independent adjudicators.
- (e) All Judicial Officers, Disciplinary Committees, Appeal Officers, Appeal Committees and Citing Commissioners shall meet the criteria for appointment in this Regulation 17 and shall be independently appointed and shall exercise their functions independently of the parties to the Match and/or proceedings and of the Unions, Associations or Rugby Bodies under whose jurisdiction responsibility falls for the relevant Match and shall not perform a legislative role in any Union, Association or Rugby Body involved in the Match and/or proceedings.
- (f) Citing Commissioners and/or Citing Commissioner Liaison Officers shall be appointed for all International Matches and Matches set out in Regulation 17.3.2 and 17.3.3. For all other Matches, or where a dispensation is granted under Regulation 17.8.6, team referrals shall be permitted which accord with Regulation 17.11.
- (g) The threshold test for citing (“Red Card” test) shall be as set out in Regulation 17.9.1.
- (h) Timelines for citings and Orderings Off and the holding of hearings for International Matches shall be strictly adhered to unless they fall within Regulation 17.8.6.
- (i) The standard of proof for Ordering Off and citing shall be as provided in Regulation 17.17.1 to 17.17.4.
- (j) Temporary Suspension policies which accord with Regulation 17.25 shall be introduced for all International Tournaments, International Tours and Series of International Matches.
- (k) Players Ordered-Off or cited by a Citing Commissioner shall be provisionally suspended pending the hearing of the case.
- (l) Suspended Players who appeal shall remain under suspension in accordance with Regulation 17.24.3.
- (m) Unions, Tournament Organisers and World Rugby shall have the right to appeal as set out in Regulation 17.22.2(a) to (c).
- (n) It is recognised that due to particular circumstances Unions or Associations or their recognised Tournament Organisers may wish for practical reasons to depart from certain provisions of Regulation 17 which are not Core Principles and where appropriate they have

the flexibility to do so provided always that no rules or procedures may be introduced (and/or omitted) by any Union, Association and/or their recognised Tournament Organisers in respect of their disciplinary rules which conflict with (and/or do not properly implement) the Core Principles of this Regulation 17, the principle of universality and/or are contrary to the Laws of the Game.

## **17.2 Application of the Regulations**

- 17.2.1 All Unions, Associations and their recognised Tournament Organisers have an obligation to put in place and implement disciplinary regulations within their jurisdictions and in respect of their tournaments and Matches which incorporate fully the Core Principles.
- 17.2.2 The Core Principles shall apply to all Unions, Associations and Tournament Organisers within their respective jurisdictions (and at all levels). The remaining provisions of Regulation 17 are mandatory guiding principles that allow flexibility in the formulation of regulations by such bodies and it is the responsibility of Unions and Associations to:
- (a) advise their Players, Persons and Rugby Bodies of this Regulation and their obligations hereunder; and
  - (b) put in place disciplinary regulations compatible and not in conflict with Regulation 17, embodying the Core Principles and to ensure that such regulations are applied to and by all Rugby Bodies within their jurisdiction.
- 17.2.3 All participants in Matches in the fifteen-a-side and seven-a-side Game and any other abbreviated versions of the Game shall be bound by the provisions of this Regulation 17.
- 17.2.4 In the event of non-compliance or improper implementation of this Regulation by any Union or Association, World Rugby may undertake such action as it considers reasonable and appropriate in the circumstances in order to address the matter with the Union or Association. Where a Rugby Body does not comply with or fails to properly implement this Regulation, the Disciplinary Officer or World Rugby may require the relevant Union(s) or Association to undertake appropriate investigations and/or proceedings to remedy the matter. In any event World Rugby shall have the authority to ensure the proper implementation of this Regulation 17 within the Game.

## **17.3 Categories of Matches**

- 17.3.1 The provisions of Regulation 17 shall apply to the categories of Matches set out in this Regulation 17.3 notwithstanding the body responsible for hosting the Match.
- 17.3.2 International Matches, International Tours, International Tournaments or Series of International Matches and which, for the purposes of this Regulation, also include:

- (a) all Matches involving The Combined Team of the Pacific Island Unions;
- (b) all Matches involving The British and Irish Lions; and
- (c) all Matches involving the senior or next senior National Representative Teams or senior National Representative Sevens Teams of a Union including where such Matches are against non-National Representative Teams played as part of an International Tour or International Tournament or Series of International Matches.

17.3.3 World Rugby Matches: which means all Matches, International Matches, International Tournaments and Series of Matches under the direct control of World Rugby and shall include but not be limited to Rugby World Cup, Rugby World Cup Sevens, Women's Rugby World Cup, World Championships, World Rugby Sevens World Series, World Rugby Sevens tournaments, designated Olympic Sevens qualification tournaments, the Olympic Games Sevens Matches and other Matches designated by World Rugby from time to time.

17.3.4 Non-International Matches

- (a) Subject to Regulation 17.3.1 and where a Citing Commissioner is not appointed, for all Matches which do not form part of an International Tour, International Tournament or Series of International Matches, the procedures set out in Regulation 17.11 shall apply.

## 17.4 Responsibility and Compliance

17.4.1 International Matches, International Tours and Series of International Matches not falling under the direct control of World Rugby

- (a) All teams participating in such International Matches shall enter into, and be bound by a Tours Agreement or Match Agreement (being the terms upon which the International Match which is not part of an International Tour is organised) as applicable.
- (b) The Tours Agreement or Match Agreement (as applicable) shall provide for the Host Union (or Tournament Organiser agreed by all the participating Unions) to be responsible for putting in place disciplinary procedures as set out in Regulation 17 and making appointments for such International Matches, save as provided in Regulation 17.5. Where Regulation 17 provides flexibility (such as with regard to timeframes for citings and/or disciplinary hearings) such detail shall be set out in the Tours Agreement or Match Agreement.
- (c) If Unions cannot agree on the disciplinary arrangements to be adopted for such Matches then they shall refer the matter to the Disciplinary Officer of World Rugby who shall determine the arrangements.



### 17.4.2 World Rugby Matches

- (a) For World Rugby Matches the provisions of this Regulation 17 may be modified and/or additional procedures and rules to those set out in this Regulation may be adopted by the Tournament Organiser or other body designated by World Rugby.
- (b) World Rugby shall make the relevant appointments in accordance with Regulation 17 and 18 for all World Rugby Matches.

### 17.4.3 International Tournaments and Cross-Border Matches

- (a) In respect of International Tournaments, the appointment and administration of Disciplinary Tribunals and Citing Commissioners may be delegated by the relevant Unions to an international Tournament Organiser subject to such body adopting disciplinary rules in compliance with this Regulation.
- (b) The Host Union or duly recognised Tournament Organiser shall be responsible for putting in place the disciplinary procedures and appointing the Disciplinary Tribunals and Citing Commissioners for the International Tournament or Cross-Border Match(es) in accordance with this Regulation.
- (c) The Host Union or duly recognised Tournament Organiser shall also put in place an agreement with all participating teams to ensure the teams and their Unions or Rugby Bodies (as appropriate) acknowledge and agree to the disciplinary rules for the International Tournament or Cross-Border Match(es), which shall be compliant with Regulation 17.

### 17.4.4 Non-International Matches

Subject to Regulation 17.4.1 to 17.4.3, responsibility for Matches shall be that of the Union in whose territory such Matches are played and that Union is responsible for ensuring compliance with Regulation 17.

17.4.5 If the Disciplinary Officer (or his nominee), considers that a Union or Association is not applying, or in a particular case did not apply disciplinary rules and procedures in accordance with this Regulation, he may take disciplinary action against the Union or Association concerned on behalf of World Rugby.

17.4.6 All Unions, Associations and Tournament Organisers shall provide to World Rugby, upon request, their disciplinary rules and procedures.

17.4.7 All disciplinary case decisions shall be made available to World Rugby upon request and in relation to all decisions in International Matches and Matches which form part of International Tours shall be immediately provided to World Rugby in writing for inclusion in the World Rugby judicial database (to [discipline@worldrugby.org](mailto:discipline@worldrugby.org)) by the responsible Union or Tournament Organiser.

## 17.5. Merit Based Appointment Scheme

17.5.1 The merit based appointment scheme was established by Council to permit the independent appointment by World Rugby of Citing Commissioners, Judicial Officers, Disciplinary Committees, Appeal Officers and Appeal Committees on a merit basis to designated Matches. The following Matches form part of the merit based appointment scheme:

- (a) World Rugby Matches;
- (b) Cross-hemisphere Summer and Autumn International Matches between the Unions forming part of the Six Nations<sup>1</sup> and Rugby Championship<sup>2</sup> International Tournaments; and
- (c) Upon application, any other Match where World Rugby gives its approval for the Match to form part of the merit based appointment scheme.

17.5.2 Where World Rugby makes appointments under the scheme reference to Host Union or Tournament Organiser appointments within this Regulation should be read as references to World Rugby.

## 17.6 Scope of Regulation 17

17.6.1 This Regulation 17 sets out the procedures for dealing with the following disciplinary matters:

- (a) When a Player is Ordered Off the playing enclosure (Red Card);
- (b) When a Player is cited for an act or acts of Foul Play (Citing); and
- (c) Where a Player has been Temporarily Suspended three times in accordance with Regulation 17.25 (Accumulated Yellow Cards).

## 17.7 Definitions - Ordering Off, Temporary Suspension and Foul Play

17.7.1 A Player is Ordered Off when he is sent off the playing enclosure permanently by the referee and can take no further part in the Match in which he was Ordered Off.

17.7.2 A Player is Temporarily Suspended when he is cautioned in a Match by the referee and temporarily sent off the playing enclosure by the referee for a period of ten minutes playing time (which is spent in the sin bin).

17.7.3 For the purposes of this Regulation 17, "Foul Play" means a breach or breaches of Law 10 of the Laws of the Game and/or a breach or breaches of Law 3.11(c) or Law 4.5(c).

---

<sup>1</sup> Being the Unions of England, France, Ireland, Italy, Scotland and Wales.

<sup>2</sup> Being the Unions of Argentina, Australia, New Zealand and South Africa.

### **17.8 Citing**

- 17.8.1 A citing arises where the duly appointed Citing Commissioner cites a Player for an act(s) of Foul Play in accordance with Regulation 17.9.1.
- 17.8.2 Citing Commissioners satisfying the general requirements of Regulation 17.13.1(a) shall be appointed for all International Matches and all Matches forming part of International Tours, International Tournaments and World Rugby Matches.
- 17.8.3 For all other Matches a Citing Commissioner should be appointed where practicable. When such appointment is not reasonably practicable, then provided the prior agreement of the participating Unions or Rugby Bodies is obtained, no Citing Commissioner may be appointed. In those circumstances team citing in accordance with Regulation 17.11 shall apply.
- 17.8.4 Unions shall strive to introduce the Citing Commissioner role within their domestic Game.
- 17.8.5 The CEO of World Rugby (or his nominee) shall have the right to review the Union policies in place with regard to citing and consider whether it is reasonably practicable for a Citing Commissioner to be appointed to designated Matches under the Union's control.
- 17.8.6 For International Matches, International Tours and/or International Tournaments or Series of International Matches where it is not reasonably practicable to appoint a citing commissioner due to resource issues and/or the non-availability of suitably qualified personnel, the Host Union may apply to the CEO of World Rugby no less than 21 days in advance of the International Match or scheduled start of the Series of International Matches for dispensation. Where World Rugby approval is granted the Union shall apply the procedures set out in Regulation 17.12.

### **17.9 Matches where a Citing Commissioner is appointed**

- 17.9.1 Citing Commissioners shall be entitled to cite a Player for any act(s) of Foul Play which in the opinion of the Citing Commissioner warranted the Player concerned being Ordered Off.
- 17.9.2 Citing Commissioners may cite Players for an act(s) of Foul Play where such act(s) may have been detected by the referee or assistant referee and which may have been the subject of referee action. A Citing Commissioner may not cite a Player for an act(s) of Foul Play in respect of which the Player has been Ordered Off save where the Ordering Off is as a result of two yellow cards. A Player in that situation may also be cited for the act(s) of Foul Play which resulted in either or both yellow card(s).
- 17.9.3 Citing Commissioners shall be entitled to issue a Citing Commissioner Warning to a Player who has in his opinion committed an act(s) of Foul Play which falls just short of warranting that the Player concerned be Ordered Off in circumstances where the act of Foul Play was not subject to a Temporary Suspension or Ordering Off.

- 17.9.4 Citing Commissioners may cite a Player if he has been Temporarily Suspended. Such citing may be made in respect of the incident(s) for which the Player was Temporarily Suspended or otherwise.
- 17.9.5 Citing Commissioners shall act independently of the Disciplinary Committee or Judicial Officer and of the Match Officials of a Match or other Citing Commissioners.
- 17.9.6 Citing Commissioners may be in attendance at the Match for which they are appointed. Where a Citing Commissioner is not present at the Match, there shall be a suitably qualified and experienced Citing Commissioner Liaison Officer in attendance at the Match who is able to provide the Citing Commissioner in accordance with the applicable timeframe with the relevant information and back-up required to assist the Citing Commissioner with his duties.

#### **17.10 Union referral to Citing Commissioner**

- 17.10.1 Where a Citing Commissioner has been appointed, the Union or other affiliated organisation responsible for the management of either participating team in a Match shall not have the power to cite a Player for Foul Play but may refer any incident of alleged Foul Play to the Citing Commissioner for consideration. Such incident shall ordinarily be referred to the Citing Commissioner within **12 hours** of the Match in which the incident is alleged to have occurred.
- 17.10.2 A Citing Commissioner's decision as to whether a Player should be cited, whether as the result of an incident referred to him or otherwise, shall be final.

#### **17.11 Matches where Citing Commissioners are not Appointed**

- 17.11.1 For Matches where, in accordance with Regulation 17.8.3 or 17.8.6, it is not reasonably practicable for a Citing Commissioner to be appointed, the following shall apply:
- (a) Each team participating in a Match, or any of its authorised officials, or its Union, may cite:
    - (i) a Player(s) for an act(s) of alleged Foul Play committed during that Match provided that such act(s) have not been detected by the Match Officials;
    - (ii) a Player for more than one incident of alleged Foul Play in the same Match; and
    - (iii) more than one Player in any Match.
  - (b) Unions and Tournament Organisers shall put in place procedures for team citing which accord with the following:
    - (i) citings by teams or their Unions shall be in writing and sent by an authorised member of the Union or management of the team to the nominated officer of the Host Union or Tournament

Organiser responsible for the Match in which the incident that is the subject of the citing complaint occurred.

- (ii) such citing, to be effective, must be made no later than **48 hours** of the conclusion of the Match in which the Foul Play is alleged to have occurred;
- (iii) the responsibility for obtaining information and reports in relation to the citing shall rest with the Union or team management making the citing complaint. The Union or team management shall liaise with the Host Union or Tournament Organiser (or its/their nominated officer) to ensure that relevant information and reports are circulated to the appropriate parties in advance of the hearing;
- (iv) the independent disciplinary body of the Union or Tournament Organiser having jurisdiction over the Match, shall consider the citing complaint and any other evidence it deems appropriate including via televisual means, oral (witness), film or photographic evidence. The Player cited shall have the right to be heard, to be represented and to produce evidence; and
- (v) at any hearing of a citing complaint a representative of the citing team or Union must be in attendance, failing which the citing complaint will be dismissed. If an act of Foul Play is found to have been committed the disciplinary body of the Union or Tournament Organiser having jurisdiction over the Match shall take the appropriate action and shall apply the World Rugby's Sanctions for Foul Play set out in Appendix 1, by following the core sanctioning principles set out in Regulation 17.19.

17.11.2 Players who are the subject of a citing by Unions shall not be provisionally suspended pending the hearing of the case.

## **17.12 Notification of Citing and Temporary Suspensions Arrangements**

17.12.1 In relation to all International Matches (whether or not they form part of an International Tour, International Tournament or Series of International Matches) it is the responsibility of the Host Union or duly recognised Tournament Organiser to notify the Disciplinary Officer, or his nominee, **28 days** prior to the commencement of the International Match of:

- (a) the identity of the Citing Commissioner who has been appointed for the International Matches and in the event of there being more than one, the Matches to which each Citing Commissioner is assigned;
- (b) whether there are any non-International Matches which form part of the International Tour, International Tournament or Series of International Matches to which Citing Commissioner(s) shall be appointed, and their identity;
- (c) the policy to be adopted for Temporary Suspensions in accordance with Regulation 17.25; and

- (d) the timelines applicable to the International Matches for team referrals, citings and the bringing of disciplinary hearings for Foul Play.

### **17.13 Disciplinary Bodies and Judicial Personnel - Constitution and Appointment**

17.13.1 For all International Matches, all Matches forming part of International Tours, International Tournaments, Series of International Matches and World Rugby Matches the Host Union or Tournament Organiser shall, subject to Regulation 17.8.6 above, appoint through an independent process the following personnel and disciplinary bodies:

- (a) An independent Citing Commissioner(s).

The Citing Commissioner shall be from a neutral Union to the participating teams, unless the participating Unions and/or teams agree otherwise. The Citing Commissioner shall have an in-depth knowledge of the Laws and skills of the Game and appropriate Rugby experience. For the purposes of Regulation 20 the Citing Commissioner may undertake the role of designated disciplinary officer.

- (b) Citing Commissioner Liaison Officer(s).

The function of the Citing Commissioner Liaison Officer shall be to liaise with and assist the Citing Commissioner in such manner as the Citing Commissioner directs. If the Citing Commissioner is not in attendance at the Match, then the Citing Commissioner Liaison Officer must be able to satisfy the minimum criteria set out in Regulation 17.9.5. For the purposes of Regulation 20 the Citing Commissioner Liaison Officer may undertake the role of designated disciplinary officer.

- (c) An independent Disciplinary Committee or Judicial Officer.

- (i) A Judicial Officer or a Disciplinary Committee comprising of three members shall be appointed.
- (ii) The Disciplinary Committee or Judicial Officer shall have jurisdiction to determine disciplinary matters arising from Players Ordered Off the playing enclosure, citings and Temporary Suspensions.
- (iii) The Members of the Disciplinary Committee or Judicial Officer shall be from a neutral Union to the participating teams unless the Participating Unions and/or teams agree otherwise in writing.
- (iv) The Chairman of the Disciplinary Committee or Judicial Officer shall be a senior legal practitioner of at least seven years standing or a serving or retired judge who shall have previous experience in rugby disciplinary proceedings and an in-depth

knowledge of the Game. Where a Disciplinary Committee is appointed, the remaining two members appointed by the Host Union or Tournament Organiser shall include an eminent former Player, experienced rugby administrator and/or legally qualified persons with previous experience in rugby disciplinary proceedings.

- 17.13.2 (a) The Host Union or Tournament Organiser through an independent process shall, when required, appoint and have available an Appeal Committee comprising of three independent members or a single independent Appeal Officer to adjudicate on appeals from decisions of Disciplinary Committees or Judicial Officers.
- (b) The Chairman of the Appeal Committee or the Appeal Officer shall be a serving or retired Judge or senior legal practitioner of at least 10 years standing who has previous experience in rugby disciplinary matters and an in-depth knowledge of the Game. The members of the Appeal Committee or the Appeal Officer shall be from a neutral Union to the participating teams unless the participating Unions and/or teams agree otherwise in writing. Where applicable, the persons to be appointed as the two additional members of the Appeal Committee may include eminent former players, experienced rugby administrators, legally qualified persons who have previous experience in rugby disciplinary proceedings or other suitably qualified personnel.
- 17.13.3 No person who is a member or an employee of a Union, Association or Tournament Organiser or other affiliated organisation responsible for the management of either team participating in a Match shall be eligible for appointment as a Citing Commissioner, Judicial Officer or member of a Disciplinary Committee or Chairman or member of an Appeal Committee or as an Appeal Officer.

#### **17.14 Initial Procedures - Ordering Off**

- 17.14.1 Where a Player in a Match is Ordered Off the referee shall, ordinarily within **2 hours** of the completion of the Match or such further time as is necessary in the circumstances, give to the nominated officer of the Host Union or Tournament Organiser a written report of the incident. Form 1 (Appendix 2 of this Regulation) may be used by the referee for this purpose.
- 17.14.2 If a Player is Ordered Off the playing enclosure as a result of the intervention of an assistant referee, the assistant referee shall also give to the nominated officer of the Host Union or Tournament Organiser a written report ordinarily within **2 hours** of the completion of the Match, or such further time as is necessary in the circumstances. Form 2 (Appendix 2 of this Regulation) may be used by an assistant referee for this purpose.
- 17.14.3 Reports prepared by referees and/or assistant referees when a Player has been Ordered Off should ordinarily contain the following information:

- (a) the date of the Match, the venue and the teams participating;
  - (b) the name of the Player Ordered Off and his team;
  - (c) the circumstances in which the Player was Ordered Off;
  - (d) the reason for the Player being Ordered Off; and
  - (e) any other information the referee (or assistant referee where applicable) considers relevant.
- 17.14.4 The Host Union's or Tournament Organiser's nominated officer shall arrange for the reports to be provided, as soon as possible, to members of the Disciplinary Committee or Judicial Officer who will adjudicate on the case. In default of appointment the nominated officer shall be deemed to be the Secretary of the Host Union or Tournament Organiser.
- 17.14.5 The Host Union's or Tournament Organiser's nominated officer shall supply the Player Ordered Off with a copy of the referee's report and, where applicable, the assistant referee's report and any other relevant evidence as soon as reasonably practicable and shall advise the Player:
- (a) of the date, place and time of the Disciplinary Committee or Judicial Officer hearing at which the disciplinary proceedings will be heard;
  - (b) of the identity of the Disciplinary Committee members or Judicial Officer;
  - (c) that he will be required to attend in person at the hearing (which may include attendance by telephone or audio-visual means at the discretion of the Disciplinary Committee or Judicial Officer);
  - (d) that if he is unable to appear at the Disciplinary Committee or Judicial Officer hearing as notified, he should advise the nominated officer of the Host Union or Tournament Organiser as soon as practicable;
  - (e) that he is entitled to adduce evidence and make submissions and be represented by his Union or team and/or a legal advisor; and
  - (f) that he is not eligible to play in any Match anywhere in the world and shall be suspended from all on-field activities on Match days pending resolution of the case.
- 17.14.6 Where possible, notice to the Player Ordered Off under this Regulation shall be given in writing. It shall be sufficient compliance with this Regulation if a copy of the referee's report and, where applicable, the assistant referee's report and any other relevant evidence together with oral notice of the information in Regulation 17.14.5 are provided to the Player or the Player's team manager or coach.
- 17.14.7 Cases involving an Ordering Off shall, where reasonably practicable, be heard within **48 hours** and no later than **72 hours** of the conclusion of the Match in which the Player was Ordered Off.



## 17.15 Initial Procedures – Citing Complaint and Citing Commissioner Warning

- 17.15.1 Subject to Regulation 17.15.3 and 17.15.4, a citing complaint by a Citing Commissioner must be sent in writing to the nominated officer of the Host Union or Tournament Organiser responsible for the Match in which the incident that is the subject of the citing complaint occurred within ordinarily a minimum of **12 hours** and no later than a maximum of **48 hours** of the conclusion of the Match. In default of appointment, the nominated officer shall be deemed to be the Secretary of the Host Union or Tournament Organiser.
- 17.15.2 For the purposes of this Regulation 17.15, a citing complaint is deemed to be sent when:
- (a) it is transmitted by facsimile or email provided that timed and confirmed notice of transmission can be provided; or
  - (b) if transmitted by some other means, when it is received by the nominated officer or Secretary of the Host Union or Tournament Organiser (or his nominee).
- 17.15.3 In circumstances where a Player has not been cited within the time periods specified in Regulation 17.15.1 as a result of either:
- (a) mistaken identity; and/or
  - (b) circumstances exist where the nature of the Foul Play incident(s) concerned is such that an investigation is needed to identify the Player(s) alleged to have committed an act(s) of Foul Play; and/or
  - (c) circumstances exist where the nature of the Foul Play incident(s) concerned is such that an investigation is needed to identify or establish the full nature of the alleged act(s) of Foul Play;
- then the citing period may be extended by the duly appointed Disciplinary Committee, Judicial Officer, Host Union or Tournament Organiser, however, any such extension will not in any event exceed **12 days** from the last date otherwise permitted by Regulation 17.15.1.
- 17.15.4 The citing complaint should ordinarily contain the following information:
- (a) the date and place of the alleged Foul Play;
  - (b) the name of the Player in respect of whom the complaint is made and the team he was playing for at the time of the alleged Foul Play;
  - (c) the name of the opposing team; and
  - (d) details of the alleged Foul Play including brief details of the evidence relied upon.

Form 3(A) (Appendix 2 of this Regulation) may be used for the purposes of making a citing complaint.

- 17.15.5 All Persons requested to provide reports and/or information must do so within the timescale requested or seek more time if required from the Citing Commissioner. Failure to provide the information and/or reports sought by the Citing Commissioner or his nominee may, in the absence of a reasonable explanation, constitute Misconduct.
- 17.15.6 The Citing Commissioner or his nominee (who may be the Citing Commissioner Liaison Officer) must obtain such reports and information as he considers necessary in relation to the cited act(s) of Foul Play. The Citing Commissioner shall provide to the Host Union or Tournament Organiser who shall in turn forward the documents and televisual evidence (where available) to the Player and other parties who were provided with a copy of the citing complaint including the relevant Match Officials.
- 17.15.7 The Host Union's or Tournament Organiser's nominated officer shall arrange for the reports and related evidence in relation to the matter to be provided, as soon as possible, to the Player and members of the Disciplinary Committee or Judicial Officer that will hear the case. The Player subject to a citing complaint shall be advised that he is not eligible to play in any Match anywhere in the world and shall be suspended from all on-field activities on Match days pending resolution of the case.
- 17.15.8 Where a Player is the subject of a citing complaint, his case should, wherever practicable, be heard ordinarily within **48 hours** and no later than **72 hours** of the conclusion of the Match in which the cited alleged Foul Play occurred.
- 17.15.9 Initial Procedures – Citing Commissioner Warning
- (a) A Citing Commissioner Warning shall be notified to the nominated officer of the Host Union or the Tournament Organiser in which the incident occurred within ordinarily a minimum 12 hours and a maximum of 48 hours of the conclusion of the relevant Match. The Citing Commissioner Warning notification shall contain the information in Regulation 17.15.4 (a) to (d). Form 3(B) (Appendix 2 of this Regulation) may be used for the purposes of notification;
  - (b) On receipt of the Citing Commissioner Warning, the nominated officer of the Host Union or Tournament Organiser shall send a copy of the notification to the Player in respect of whom it is made, his team management and the appropriate Match Officials of the Match in which it is alleged the Foul Play occurred.
- 17.16 Initial Procedures - Citing by Unions**
- 17.16.1 The procedures to be applied for a citing by a Union in circumstances where a Citing Commissioner has not been appointed, shall as far as reasonably practicable, be as set out in Regulation 17.11.

**17.17 Standard of Proof for Ordering Off and Citing**

- 17.17.1 The standard of proof for all matters under this Regulation shall be on the balance of probabilities.
- 17.17.2 The integrity of Law 6.A.4(a) of the Laws of the Game and the referee's position as sole judge of fact and law during the Match is unassailable. With the sole exception of Regulation 17.19.7 the referee's decisions on the field of play and their sporting consequences shall not be altered or overturned by a ruling of a Disciplinary Committee or Judicial Officer. The purpose of a subsequent review of an incident that occurred during a Match, by a Citing Commissioner and/or Disciplinary Committee or Judicial Officer, is to determine whether there should be any disciplinary sanctions applied for an act of Foul Play as provided for in Law 10.
- 17.17.3 In the case of an Ordering Off, the function of the Disciplinary Committee or Judicial Officer is to consider the circumstances of the case and determine its/his factual findings and what further sanction, if any, should be imposed on the Player. The Player Ordered Off may seek to show that the referee's decision was wrong and the Disciplinary Committee or Judicial Officer may, subject to 17.17.2 review the referee's decision and the circumstances surrounding it. In any such case, the Disciplinary Committee or Judicial Officer shall not make a finding contrary to the referee's decision unless it/he is satisfied, on the balance of probabilities that the referee's decision was wrong.
- 17.17.4 (a) In the case where there has been a citing complaint, the function of the Disciplinary Committee or Judicial Officer is to determine whether an act of Foul Play was committed by the Player. Where a Player accepts that there has been Foul Play or Foul Play is established to the satisfaction of the Disciplinary Committee or Judicial Officer in accordance with 17.17.4(a), the cited Player may seek to show that the Citing Commissioner's decision to cite was wrong and the Disciplinary Committee or Judicial Officer may review the Citing Commissioner's decision and the circumstances surrounding it. In any such case, the Disciplinary Committee or Judicial Officer shall not make a finding contrary to the Citing Commissioner's decision to cite unless it/he is satisfied, on the balance of probabilities that the Citing Commissioner's decision was wrong. If the citing is upheld, the Disciplinary Committee or Judicial Officer shall determine the sanction to be imposed on the Player in accordance with Regulation 17.19. In determining the appropriate sanction, the Disciplinary Committee or Judicial Officer may take account of any action taken during the Match in respect of the Foul Play by the referee.
- (b) In citing cases involving Matches in which no Citing Commissioner was appointed, the Disciplinary Committee or Judicial Officer shall, prior to considering whether the citing complaint by a team is to be upheld, establish that the incident was undetected by the referee and/or assistant referees and whether the alleged Foul Play was

sufficiently serious to warrant an Ordering Off. If the Disciplinary Committee or Judicial Officer does not consider the alleged Foul Play of sufficient seriousness to have warranted an Ordering Off they/he shall dismiss the citing complaint.

**17.18 Disciplinary Committees and/or Judicial Officers - Powers and Procedures**

- 17.18.1 The General Procedures relating to hearings before Disciplinary Committees and Judicial Officers contained in Regulation 18, Appendix 1 shall apply to any matter arising under this Regulation.
- 17.18.2 The referee of the Match in which the Player is Ordered Off (and, if a Player is Ordered Off as a result of an assistant referee's intervention, the assistant referee) shall, unless exceptionally permitted by the Disciplinary Committee or Judicial Officer, attend the hearing (whether in person or via telephonic and/or audiovisual means). Nothing in this Regulation shall prevent the Disciplinary Committee or Judicial Officer hearing and determining disciplinary proceedings in the absence of the referee and/or assistant referee.
- 17.18.3 The Citing Commissioner of the Match in which the Player is cited shall, if so required by the Disciplinary Committee or Judicial Officer, attend the hearing (whether in person or via telephone and/or audiovisual means) for the purposes of providing evidence and/or a further explanation of the factual material relied upon in the making of the citing.
- 17.18.4 In respect of cases involving the Ordering Off or citing of a Player, the Disciplinary Committee or Judicial Officer shall ensure that, prior to the hearing, the Player Ordered Off or cited has been supplied with, and has had a sufficient opportunity to consider, the referee's report and the report of the assistant referee (where applicable), and/or the citing report together with any other information, reports or evidence.
- 17.18.5 Any electronic recording of an incident permitted in evidence by a Disciplinary Committee or Judicial Officer shall preferably be viewed without the sound or commentary associated with it being heard, save where the sound or commentary includes the comments made by the referee through his microphone in relation to the specific incident in question or if the parties agree that the sound or commentary should be played.
- 17.18.6 At any hearing the Disciplinary Committee or Judicial Officer may direct that the Host Union or Tournament Organiser be represented. If so, the Union or Tournament Organiser shall appear by counsel or by a representative at the hearing, in such capacity as the Disciplinary Committee or Judicial Officer requires, to provide assistance to the Disciplinary Committee or Judicial Officer in the discharge of its duties.

- 17.18.7 The Disciplinary Officer (or his nominee), or the disciplinary officer of the Host Union or Tournament Organiser (as the case may be) shall be permitted representation at any hearing arising out of any alleged acts of Foul Play arising from Matches within their jurisdiction and/or control.
- 17.18.8 Where evidence is given before a Disciplinary Committee or Judicial Officer there shall be no cross-examination of any witness other than by Disciplinary Committee members or the Judicial Officer except to the extent allowed by the Disciplinary Committee or Judicial Officer.
- 17.18.9 For citing complaints initiated by Unions, in circumstances where a Citing Commissioner was not appointed, the Union citing the Player must have a representative in attendance at the hearing to present the basis of the citing complaint and evidence in support. Failure to attend by the Union representative shall result in the case being dismissed.
- 17.18.10 The Player subject to the proceedings (a) shall appear before the Disciplinary Committee, in person or via technological means; (b) may admit the act or alleged act of Foul Play at any time, in which case the Disciplinary Committee or Judicial Officer should proceed immediately to hear evidence and/or submissions as to the sanction, if any, to be imposed.
- 17.18.11 Subject always to Regulation 17.17.4, the Disciplinary Committee or Judicial Officer shall, in the first instance, in the case of a citing determine whether the act of Foul Play has been committed. In the case of an Ordering Off the Disciplinary Committee or Judicial Officer shall, in the first instance, determine its/his factual findings in relation to matters that can be properly raised in accordance with Regulation 17.17.3. Thereafter, as appropriate, it will reconvene and hear and consider evidence and submissions in relation to sanctions.

### **17.19 Sanctions and Core Sanctioning Process**

- 17.19.1 In any case where a Disciplinary Committee or Judicial Officer considers an incident(s) of Foul Play has occurred, it/he may decide to impose a sanction in accordance with the provisions of this Regulation 17.19. When imposing sanctions, all Disciplinary Committees or Judicial Officers dealing with an Ordering Off and/or citing shall apply the World Rugby's sanctions for Foul Play set out in Appendix 1 and do so in accordance with this Regulation 17.19.

#### **Assessment of seriousness of the Foul Play**

- 17.19.2 Disciplinary Committees or Judicial Officers shall undertake an assessment of the seriousness of the Player's conduct that constitutes the offending and categorise that conduct as being at the lower end, mid range or top end of the scale of seriousness in order to identify the appropriate entry point for consideration of a particular incident(s) of Foul Play where such incident(s) is expressly covered in Appendix 1. The assessment of the seriousness of the Player's conduct shall be determined by reference to the following features:

- (a) whether the offending was intentional or deliberate;
- (b) whether the offending was reckless, that is the Player knew (or should have known) there was a risk of committing an act of Foul Play;
- (c) the gravity of the Player's actions in relation to the offending;
- (d) the nature of the actions, the manner in which the offence was committed including part of body used (for example, fist, elbow, knee or boot);
- (e) the existence of provocation;
- (f) whether the Player acted in retaliation and the timing of such;
- (g) whether the Player acted in self-defence (that is whether he used a reasonable degree of force in defending himself);
- (h) the effect of the Player's actions on the victim (for example, extent of injury, removal of victim Player from the game);
- (i) the effect of the Player's actions on the Match;
- (j) the vulnerability of the victim Player including part of victim's body involved/affected, position of the victim Player, ability to defend himself;
- (k) the level of participation in the offending and level of premeditation;
- (l) whether the conduct of the offending Player was completed or amounted to an attempt; and
- (m) any other feature of the Player's conduct in relation to or connected with the offending.

Based on the assessment of the offence(s) under consideration against the above features of offending, the Disciplinary Committee or Judicial Officer shall categorise the act of Foul Play as being at the lower end, mid range or top end of the scale of seriousness of offending and identify the applicable entry point as set out in Appendix 1.

- 17.19.3 For offences categorised at the top end of the scale of seriousness of offending, the Disciplinary Committee or Judicial Officer shall identify an entry point between the period shown as the top end for the particular offence and the maximum sanction in Appendix 1.<sup>3</sup>

### **Aggravating Factors**

- 17.19.4 Having identified the applicable entry point for consideration of a particular incident, the Disciplinary Committees or Judicial Officers shall identify any relevant off-field aggravating factors and determine what additional period

---

<sup>3</sup> The plus sign against each top end period suspension denotes this entitlement and flexibility.

of suspension, if any, above the applicable entry point for the offence should apply to the case in question. Aggravating factors include:

- (a) the Player's status generally as an offender of the Laws of the Game;<sup>4</sup>
- (b) the need for a deterrent to combat a pattern of offending in the Game; and
- (c) any other off-field aggravating factor(s) that the Disciplinary Committee or Judicial Officer considers relevant and appropriate.

### **Mitigating Factors**

17.19.5 Thereafter, the Disciplinary Committee or Judicial Officer shall identify any relevant off-field mitigating factors and determine if there are grounds for reducing the period of suspension and subject to Regulations 17.19.6 and 17.19.7 the extent, if at all, by which the period of suspension should be reduced. Mitigating factors include the following:

- (a) the presence and timing of an acknowledgement of culpability/wrong-doing by the offending Player;
- (b) the Player's disciplinary record and/or good character;
- (c) the youth and inexperience of the Player;
- (d) the Player's conduct prior to and at the hearing;
- (e) the Player having demonstrated remorse for his conduct to the victim Player including the timing of such remorse; and
- (f) any other off-field mitigating factor(s) that the Disciplinary Committee or Judicial Officer considers relevant and appropriate.

17.19.6 Subject to Regulations 17.19.7 and 17.19.8, for acts of Foul Play the Disciplinary Committee or Judicial Officer cannot apply a greater reduction than 50% of the relevant entry point suspension. In assessing the percentage reduction applicable for mitigating factors, the Disciplinary Committee or Judicial Officer shall start at 0% reduction and apply the amount, if any, to be allowed as mitigation up to the maximum 50% reduction.

17.19.7 In cases involving offending that has been classified pursuant to Regulation 17.19.2 as lower end offending, where:

- (a) there are off-field mitigating factors; and

---

<sup>4</sup> *The Player's disciplinary record in all competitions and (as appropriate) in other sports during his playing career from the age of 18 shall be considered by a Disciplinary Committee or Judicial Officer. In any case in which the Disciplinary Committee or Judicial Officer establishes that the Player has previously been found by a Judicial Officer and/or Disciplinary Committee to have committed any act of Foul Play and/or Misconduct then the Disciplinary Committee or Judicial Officer in imposing any sanction on the Player may in fixing that sanction take account of such offending as an aggravating factor.*

- (b) where the Disciplinary Committee or Judicial Officer considers that the sanction would be wholly disproportionate to the level and type of offending involved;

the Disciplinary Committee or Judicial Officer may apply sanctions less than 50% of the lower end entry sanctions specified in Appendix 1 including in appropriate cases no sanction. In exceptional cases where the Disciplinary Committee or Judicial Officer considers it is warranted it/he may (i) expunge the Ordering Off (Red Card) from the Player's disciplinary record, or (ii) in the case of a Temporary Suspension (Yellow Card) issued by the referee, solely in circumstances attributed to mistaken identity, may expunge the Temporary Suspension from the Player's disciplinary record.

- 17.19.8 In cases of multiple offending, Disciplinary Committees and Judicial Officers may impose sanctions to run either on a concurrent or a consecutive basis provided that the total sanction is in all the circumstances proportionate to the level of the overall offending.
- 17.19.9 Disciplinary Committees and Judicial Officers shall ordinarily in their written decisions set out the reasoning for their findings, including the finding on culpability, how they have categorised the seriousness of the offence by reference to the features set out in Regulation 17.19.2, how they identified and applied any aggravating and mitigating factors and conclude with the resultant sanction, if any, imposed.
- 17.19.10 Decisions on sanctions and suspensions imposed on Players under World Rugby Regulation 17 shall:
  - (a) be applied universally by Unions, Associations, Rugby Bodies and their constituent bodies such that the Player may not play the Game (or any form thereof) or be involved in any on-field Match day activities anywhere during the period of suspension;
  - (b) not allow Players to avoid the full consequences of their actions by, for example, playing in Matches prior to the commencement of their suspension, or playing in Matches during a break in the suspension and/or serving their suspension during a period of inconsequential pre-season and/or so-called friendly Matches;
  - (c) apply and be served when the Player is scheduled to play;
  - (d) be imposed until a stated date which should be fixed after taking into consideration all playing consequences of such suspension; and
  - (e) be effective immediately (subject to 17.19.11(b)).
- 17.19.11 When imposing suspensions on Players under Regulation 17 Disciplinary Committees or Judicial Officers shall comply with the requirements set out in Regulation 17.19.10 above. In doing so Disciplinary Committees or Judicial Officers:
  - (a) must not suspend the effect of any sanction imposed;



- (b) may defer the commencement of a suspension provided that the Player is not scheduled to play (and will not be permitted to play) prior to the commencement of the suspension;
- (c) shall, in respect of meaningful off-season application of sanctions, set out the reasons why it or he considers those Matches to be meaningful;
- (d) may, at its/his discretion in assessing the playing consequences of a sanction apply the suspension to scheduled pre-season and/or so-called friendly Matches, provided such scheduled pre-season and/or so-called friendly Matches have, in the opinion of the Disciplinary Committee or Judicial Officer concerned, a meaningful playing consequence for the Player. In making their assessment Disciplinary Committees and Judicial Officers may, in their discretion, take account of such factors as they consider relevant including, for example, the proximity of the Match to the commencement of the season, the identity and stature of the opponents, likely quality of teams to be selected, and the general Match profile;
- (e) must, if a Player's suspension has not terminated by the end of the current playing season, continue the suspension until a stated date in the next playing season, unless the Player has been selected for a closed season tour, or he has made plans to play during the close of season in another Union. In this event (and subject to the Disciplinary Committee or Judicial Officer receiving satisfactory verification of such tour or playing arrangements), the period of the tour or the fact that he intends to play in another Union shall be taken into account in determining when the suspension shall come to an end; and
- (f) may divide the suspension into two separate periods in order to exclude the whole or part of the closed season provided that the Player is not permitted to play during such closed season.

17.19.12 In respect of offences not referred to in the World Rugby Sanctions in Appendix 1, appropriate sanctions may be imposed at the discretion of the relevant Judicial Officer, Disciplinary Committee, Appeal Officer and/or Appeal Committee.

17.19.13 Notwithstanding the World Rugby Sanctions in Appendix 1 and/or the provisions of this Regulation 17.19 in cases where the Player's actions constitute mid range or top end offending for any type of offence which had the potential to result and, in fact, did result in serious/gross consequences to the health of the victim, the Judicial Officer and/or Disciplinary Committee may impose any period of suspension including a suspension for life.

## **17.20 Costs**

17.20.1 As a general principle and subject to Regulation 17.20.2 and 17.20.3 below, the Host Union or Tournament Organiser shall ordinarily bear the

cost of holding the hearing, including the travel, accommodation and/or costs of the Disciplinary Committee members or Judicial Officer and/or Match Officials, Citing Commissioner and other witnesses called by the Disciplinary Committee or Judicial Officer as well as the costs of interpretation, recording and/or transcription and legal advice for the Disciplinary Committee or Judicial Officer.

- 17.20.2 The Player that is the subject of the proceedings or his Union shall pay his/their own costs, including travel/accommodation costs of the Player, his representatives and his witnesses, as well as his legal costs.
- 17.20.3 Notwithstanding the provisions of this Regulation 17.20, Disciplinary Committees and Judicial Officers shall have complete discretion to impose such cost orders as to the payment of costs relation to any proceedings, including the nature of costs set out in Appendix 1 to Regulation 18.

## **17.21 Post-Hearing Procedures**

- 17.21.1 The decision of the Disciplinary Committee or Judicial Officer shall be advised to applicable parties, as soon as practicable after the hearing and shall be binding on notification to the Player or his representative or Union. The Disciplinary Committee or Judicial Officer may deliver a short oral decision at the conclusion of the hearing (with its/his reasons to be put in writing and communicated to the parties at a later date) or it/he may reserve the decision. If an oral decision is made it shall be binding from the time of communication to the parties.
- 17.21.2 Relevant parties heard by the Disciplinary Committee or Judicial Officer shall be entitled to a copy of the final written decision which shall, where practicable, be sent to them by the Host Union or Tournament Organiser within **48 hours** of its being made available. The timelines for notifying World Rugby in Regulation 17.4.7 shall also be met.
- 17.21.3 Where a relevant party (including a Player, applicable Union(s) or Rugby Body) is adversely affected by a disciplinary decision such party shall be notified by the Disciplinary Committee or Judicial Officer of the circumstances in which an appeal to an Appeal Committee or Appeal Officer may be made. Such notification shall, ordinarily, be included in the Disciplinary Committee's or Judicial Officer's final written decision and notified at the conclusion of the hearing if an oral decision is given.
- 17.21.4 The hearing by the Disciplinary Committee or Judicial Officer may be audio or audio-visually recorded or recorded by a stenographer. The record of the proceedings, and all papers associated with the proceedings, shall be held for a suitable period by the Host Union or Tournament Organiser. Copies of the record shall be made available to the relevant parties at reasonable cost only on appeal of the decision of the Disciplinary Committee or Judicial Officer. Notwithstanding the foregoing, copies of the record shall be made available to World Rugby upon its request.

**17.22 Appeals**

17.22.1 For the purposes of Regulation 17.22, “decision” shall mean the final written decision of the Disciplinary Committee or Judicial Officer.

17.22.2 (a) A Player and/or the Player’s Home Union/Rugby Body (as appropriate) may appeal to an Appeal Committee or Appeal Officer from a decision of a Disciplinary Committee or Judicial Officer. Any appeal of such decision must be lodged with the nominated officer of the Host Union or Tournament Organiser (as applicable) within **48 hours** of the date on which the decision of the Disciplinary Committee or Judicial Officer has been notified or in default, with the Secretary of the Host Union or the disciplinary officer of the Tournament Organiser (as applicable).

(b) The following additional parties shall be entitled to appeal to an Appeal Committee or Appeal Officer from the decision of a Disciplinary Committee or Judicial Officer:

(i) Host Union; and/or

(ii) Tournament Organiser; and/or

(iii) World Rugby in respect of all World Rugby Matches and Matches falling under the merit based appointment scheme;

such parties shall lodge an appeal as soon as reasonably practicable but in any event no later than **72 hours** following receipt by the appealing party of the decision.

(c) World Rugby has a supervisory jurisdiction in respect of disciplinary matters under this Regulation. In the event the Disciplinary Officer determines it is appropriate that a particular decision should be appealed in respect of International Matches, where there is no appropriate hosting body for a Match and/or where the disciplinary regulations for a Match are clearly contrary to Regulation 17, the Disciplinary Officer or other nominee of World Rugby may take such steps as are reasonably necessary to review the matter and make such recommendations to World Rugby as he deems appropriate. The Disciplinary Officer (or other nominee of World Rugby) may appeal the matter and such right of appeal shall be exercised within **72 hours** following receipt of the decision.

17.22.3 An appeal shall be deemed to have been lodged by the relevant party (Appellant) when the notice of appeal is received by the nominated officer of the Host Union or Tournament Organiser (or in default the Secretary or Disciplinary Officer of such body) within the timeframes set out in 17.22.2 together with any required deposit referred to in Regulation 17.22.5.

17.22.4 The notice of appeal shall be in writing and signed by the particular Appellant lodging the appeal and shall specify the:

(a) name of the Appellant lodging the appeal;

- (b) decision appealed against;
- (c) date of the decision appealed against;
- (d) date of receipt of the decision appealed against by the party appealing; and
- (e) grounds of the appeal.

Except as provided, no specific form of a notice of appeal is required.

17.22.5 If the Host Union or Tournament Organiser shall so require, each notice of appeal shall be accompanied by a deposit of an amount not exceeding the equivalent of £1,000 (pounds Sterling), such amount to be determined by the Host Union or Tournament Organiser. In the event of a required deposit not being paid, the appeal shall be deemed to be abandoned, save that the Appeal Committee or Appeal Officer, in any case, shall have power to extend the time for payment of the deposit. In the event of an appeal by World Rugby, the Host Union or Tournament Organiser no appeal deposit shall be payable.

17.22.6 On the lodgement of the appeal the Host Union or Tournament Organiser shall:

- (a) notify the applicable parties in Regulation 17.22.2 of the appeal; and
- (b) make available to the Appeal Committee or Appeal Officer (and the Appellant(s)) the full record of the proceedings before the Disciplinary Committee or Judicial Officer.

#### **Appeal Committee or Appeal Officer**

17.22.7 The Appeal Committee or Appeal Officer shall determine the basis on which the appeal shall proceed. The General Procedures relating to hearings before Appeal Committees and Appeal Officers contained in Regulation 18, Appendix 1 shall apply to any matter arising under this Regulation.

17.22.8 The Appellant(s) will be notified of the names of the Appeal Committee members or Appeal Officer and the fact that the Player is not eligible to play the Game (or any form thereof) or be involved in any on-field Match day activities anywhere in the world pending the appeal save always where no sanction has been imposed by the Disciplinary Committee or the Judicial Officer and/or that where a Player's suspension expires while his appeal is pending the Player shall be eligible to play immediately.

17.22.9 An appeal should, where reasonably practicable, be heard within **7 days** after its lodgement.

17.22.10 In any appeal before the Appeal Committee or Appeal Officer:

- (a) an Appellant that is a Player may be represented by a Union representative and/or legal counsel. Any other appellant may be

represented by legal counsel and/or another representative of the Appellant;

- (b) where the Host Union or Tournament Organiser appeals they shall be represented by a designated disciplinary officer of that body (and/or his nominee);
- (c) where World Rugby appeals they shall be represented by the Disciplinary Officer (and/or his nominee).

17.22.11 If an Appeal Committee or Appeal Officer allows further evidence to be adduced at a hearing, there shall be no cross-examination of witnesses except to the extent allowed by the Appeal Committee or Appeal Officer.

### **17.23 Additional Provisions Relating to Hearings**

17.23.1 In all proceedings heard by a Disciplinary Committee or Judicial Officer and/or Appeal Committee or Appeal Officer, referees and/or assistant referees may only give evidence of fact, not opinion.

17.23.2 Disciplinary Committees, Judicial Officers, Appeal Committees and Appeal Officers, prior to a hearing or at any stage during a hearing may amend the offence for which the Player has been Ordered Off or cited unless, having regard to the circumstances of the case, such amendment cannot be made without causing injustice. Where an amendment is made, in appropriate cases an adjournment may be granted.

### **17.24 Suspension**

17.24.1 A Player Ordered Off or cited by a Citing Commissioner may not take part or be selected for any further Match until his case has been dealt with by a Disciplinary Committee or Judicial Officer.

17.24.2 Without in any way limiting the effect of Clause 17.19.11, a Player that is subject to an Ordering Off or citing in a domestic or any other Match is not entitled to play the Game (or any form thereof) or be involved in any on-field Match day activities anywhere in the world until his case has been finally resolved.

17.24.3 A suspended Player who elects to appeal may not take part or be selected for any further Match until his case has been dealt with by an Appeal Committee or Appeal Officer or the expiry of his suspension whichever occurs earlier.

### **17.25 Temporary Suspensions and Citing Commissioner Warnings**

17.25.1 All Unions, for competitions within their jurisdictions and Tournament Organisers International Tournaments or Series of International Matches have an obligation to put in place provisions to regulate the administration and disciplinary consequences arising out of Temporary Suspensions and Citing Commissioner Warnings (including with respect to the accumulation of a combination of three Temporary Suspensions and/or Citing Commissioner Warnings).

17.25.2 The following principles shall be applied for Temporary Suspensions subject to such modifications as may be necessary in the context of the relevant Union competitions, International Tournament or Series of International Matches:

- (a) the referee must report each Temporary Suspension at the conclusion of the Match in which the Temporary Suspension was imposed;
- (b) the report which may be in a standard form shall be forwarded to the nominated officer of the Host Union or Tournament Organiser, where reasonably practicable, within **2 hours** following the completion of the Match in which the Temporary Suspension was imposed. For the purposes of this Regulation 17.25.2 the nominated officer shall be the Secretary of the Host Union or the disciplinary officer of the Tournament Organiser;
- (c) the Host Union or Tournament Organiser shall forward a copy of the report to the relevant parties within **48 hours** of receipt. Such report shall clearly state that the Player has the right to challenge the Temporary Suspension but if he wishes to do so he must give notice of his challenge, ordinarily specifying reasons, within **48 hours** of receipt. Such notice shall be duly recorded by the Host Union or Tournament Organiser and shall be considered in the event of the Player subsequently being involved in any judicial hearing in relation to the accumulation of Temporary Suspensions;
- (d) a Player who has been Temporarily Suspended on three or more occasions and/or received a combination of three or more Temporary Suspensions in any particular tournament or competition or Series of Matches under the jurisdiction of the Host Union or Tournament Organiser (for International Matches) during a single season shall be required to appear before a Disciplinary Committee or Judicial Officer independently appointed by the Host Union or Tournament Organiser at an appointed time and place. At that time the Player will be notified as follows:
  - (i) that the purpose of the hearing is to consider whether any further penalty should be imposed on him for his persistent offending;
  - (ii) that he may be represented by his Union and/or by a legal representative;
  - (iii) that save where the Player has given notice of his intention to challenge a Temporary Suspension within the time period specified in 17.25.2(c) above and in the absence of exceptional circumstances relating to the failure to give the prescribed notice, no evidence will be heard other than on the question of sanction;

- (iv) the identity of the Disciplinary Committee members or Judicial Officer, as the case may be; and
  - (v) that the Player shall not be permitted to play in any Match and shall be suspended from all on-field activities on Match days anywhere in the world pending the outcome of his case;
  - (e) the general procedures for hearings and appeals under Regulation 17, subject to such modifications as may be necessary, shall also apply to the hearings and appeals in relation to the accumulation of Temporary Suspensions; and
  - (f) Given the numerous permutations of potential sanctions that could arise in cases involving accumulated Temporary Suspensions the sanctioning of the Player shall be solely within the discretion of the Disciplinary Committee or Judicial Officer.
- 17.25.3 The Citing Commissioner Warning shall become part of the Player's disciplinary record. In this regard:
- (a) The Citing Commissioner is not limited in the number of Citing Commissioner Warnings he may issue to a Player for Foul Play during a Match;
  - (b) If a Player has received two Citing Commissioner Warnings or a combination of a Citing Commissioner Warning and a Temporary Suspension during a Match he shall be treated for disciplinary purposes as if he had been Ordered Off;
  - (c) If the Player concerned wishes to challenge the Citing Commissioner Warning, he shall give notice of his intention to challenge it within 48 hours of its notification. Such notice shall be duly recorded by the Host Union or Tournament Organiser and shall be considered in the event of the Player subsequently being involved in any judicial hearing in relation to the accumulation of Temporary Suspensions and/or Citing Commissioner Warnings;
  - (d) If a Player has received three Citing Commissioner Warnings or a combination of three Citing Commissioner Warnings and/or Temporary Suspensions in a tournament, competition or a Series of Matches under the jurisdiction of a Host Union or Tournament Organiser during a single season, he shall be required to appear before a Disciplinary Committee or Judicial Officer independently appointed by the Host Union or Tournament Organiser. At that time, the Player shall be notified as follows:
    - (i) that the purpose of the hearing is to consider whether any further penalty should be imposed on him for his persistent offending;
    - (ii) that he may be represented by his Union and/or by a legal representative;

- (iii) the identity of the appointed Disciplinary Committee members or Judicial Officer; and
- (iv) that the Player shall not be permitted to play any Match and shall be suspended from all on-field activities on Match days anywhere in the world pending the outcome of his case.

## **17.26 Exceptional Circumstances in relation to Players' Conduct**

- 17.26.1 In exceptional circumstances where the conduct of a Player(s) or Person(s) is of such a serious/gross nature that his or their continued involvement in the Game in any capacity pending the final determination of the matter by the relevant authority is deemed by World Rugby to be inappropriate and/or potentially prejudicial to the image and reputation of the sport, then World Rugby is entitled to require as it deems fit that the relevant Union(s) provisionally suspend such Player(s) or Person(s) from any involvement in the sport.
- 17.26.2 It is the responsibility of each Union in membership of World Rugby to ensure that in such circumstances it is able by reference to its regulations or otherwise to effect and/or recognise such provisional suspension on the Player or Person concerned.

## **17.27 Unforeseen Circumstances**

- 17.27.1 In the event that a particular incident takes place for which there is no provision in this Regulation 17 then the Disciplinary Officer, or his nominee may take such action that he considers appropriate in the circumstances in accordance with general principles of natural justice and fairness.

## **17.28 Miscellaneous**

- 17.28.1 In circumstances where an act of Foul Play and an act of Misconduct (as defined in Regulation 20) arise in respect of the same Match for the same Player and provided it does not give rise to an injustice to the Player, for convenience both matters may be dealt with by the same Judicial Officer or Disciplinary Committee, notwithstanding that the acts may be governed by different Regulations.
- 17.28.2 Procedures or proceedings under this Regulation and/or Regulation 18 or any decision of a Disciplinary Committee, Judicial Officer, Appeal Committee or Appeal Officer shall not be quashed or held invalid by reason only of any defect, irregularity, omission or other technicality unless such defect, irregularity, omission or technicality raises a material doubt as to the reliability of the findings or decisions of a Disciplinary Committee, Judicial Officer, Appeal Committee or Appeal Officer or results in a miscarriage of justice.



## MODIFIED PROCEDURES FOR FOUL PLAY IN SEVENS

### 17.29 Introduction

- 17.29.1 In recognition of the unique structure of Sevens Tournaments and Series of Matches and the timelines within which the Sevens Game operates, the following provisions shall apply to the Sevens Game for Foul Play.
- 17.29.2 For the avoidance of doubt, references in Regulations 17.3, 17.4 and 17.5 to International Tournaments, International Tours and Series of International Matches includes Sevens International Matches. All other references to Matches shall include Sevens.

### 17.30 Application of the Regulations

- 17.30.1 In respect of all Sevens Matches the procedures and standards in respect of the fifteen-a-side game as provided in Regulation 17 shall apply equally to Sevens save as provided in Regulation 17.31 to 17.32 below. In particular the following provisions shall apply:
- (a) Initial Procedures - Ordering Off; as per Regulation 17.14 save as amended by Regulation 17.31;
  - (b) Initial Procedures – Citing and Citing Commissioner Warning; as per Regulation 17.15 and 17.16 save as amended by Regulation 17.32;
  - (c) Judicial Officer - Powers and Procedures; as per Regulations 17.18 and Regulation 18, Appendix 1 save as amended by Regulation 17.33;
  - (d) Sanctions; as per Regulation 17.19 save as amended in Regulation 17.34;
  - (e) Appeals; per Regulation 17.22 save as amended in Regulation 17.36; and
  - (f) Suspensions; as per Regulation 17.24 and Temporary Suspensions and Citing Commissioner Warnings as per Regulation 17.25 save as amended in Regulation 17.35.

### 17.31 Initial Procedures - Ordering Off

- 17.31.1 If a Player is Ordered Off the playing enclosure in a Sevens Match, his case shall, whenever practicable, be adjudicated on within **2 hours** of the conclusion of that Match, or prior to him playing another Match in the Tournament (whichever is earlier).
- 17.31.2 Form 4 (Appendix 2 of this Regulation) may be used by the referee for the purposes of a report under Regulation 17.14.1.
- 17.31.3 Form 5 (Appendix 2 of this Regulation) may be used by the assistant referee for the purposes of a report under Regulation 17.14.2.

17.31.4 In light of the specific time pressures in Sevens Tournaments and Series of Matches it is not necessary that notice provided for in Regulation 17.14.5 be given in writing to the Player Ordered Off. It shall be sufficient compliance with this Regulation if the referee's report and where applicable, the assistant referee's report and any other relevant evidential material together with notice of the information required in Regulation 17.14.5, are handed to the Player or the Player's team manager.

### **17.32 Initial Procedures – Citing and Citing Commissioner Warning**

17.32.1 The Union or other affiliated organisation responsible for the management of either participating team in a Sevens Match shall not have the power to cite a Player for Foul Play but may refer any incident of Foul Play to the Citing Commissioner for consideration provided such incident is referred to the Citing Commissioner within **30 minutes** of the completion of the Match in which the incident is alleged to have occurred. A Citing Commissioner's decision as to whether a Player should be cited (or not, as the case may be), whether as the result of an incident referred to him or otherwise shall be final.

17.32.2 Form 3(A) (Appendix 2 of this Regulation) may be used by the Citing Commissioner for the purposes of making a citing complaint.

17.32.3 A citing complaint by a Citing Commissioner should ordinarily contain the information provided in Regulation 17.15.4 and be received by the appointed disciplinary officer or in default the Secretary of the Host Union or Tournament Organiser within **60 minutes** of the end of the Match in which the act or acts of Foul Play is alleged to have taken place.

17.32.4 The exceptional circumstances for citing out of time in Regulation 17.15.3 shall also apply to Sevens and in addition, upon application by the Citing Commissioner to the Judicial Officer, the time period for citing may be extended where there are extenuating circumstances provided always that the extension of time does not extend beyond the duration of the Tournament.

17.32.5 Where a Player is the subject of a citing complaint his case wherever practicable should be adjudicated on within **2 hours** of the citing complaint being received by the Player or prior to his next scheduled Match.

17.32.6 A Citing Commissioner Warning shall be notified to the nominated officer of the Host Union or the Tournament Organiser in which the incident occurred ordinarily within 60 minutes of the end of the Match in which the act or acts of Foul Play is alleged to have taken place. The Citing Commissioner Warning notification shall contain the information in Regulation 17.15.4 (a) to (d). Form 3(B) (Appendix 2 of this Regulation) may be used for the purposes of notification.

### 17.33 Judicial Officer – Power to Regulate Own Procedures

- 17.33.1 In Sevens, any case involving an Ordering Off, Citing, Temporary Suspensions will be adjudicated on by a Judicial Officer who shall act as sole arbiter.
- 17.33.2 Any matters not provided for in these Modified Procedures for Sevens or Regulation 17 shall in the first instance be referred to a Judicial Officer who shall deal with such matter as he sees fit.

### 17.34 Sanctions in a Sevens context

- 17.34.1 The World Rugby's Sanctions for Foul Play set out in Appendix 1 have been established on the basis that a one week period of suspension would normally result in a Player missing one Match of Fifteens. During a Sevens Tournament, Players may participate or participating Unions may be scheduled to participate in several Matches per day. When determining the appropriate periods of suspension, a Judicial Officer should take cognisance of the fact that during a Sevens Tournament or Series of Matches a Player may miss more than one Match as a result of being made subject to a week's suspension and may impose a suspension based on a number of Tournament Matches. In this respect the Judicial Officer shall have regard to the overall impact of the suspension. This provision does not preclude the imposition of periods of suspension running beyond a Player's participation in the Tournament.
- 17.34.2 The Judicial Officer shall convey his decision using the standard form (a copy of which appears as Form 6 at Appendix 2 of this Regulation 17) or otherwise in writing as soon as reasonably practicable to the Player, to the teams involved in the Match, the appointed disciplinary officer and to World Rugby. The decision shall be binding on the Player as soon as he, his representative, or his team is notified of the decision. "Decision" shall have the meaning set out in Regulation 17.22.1.

### 17.35 Temporary Suspension and Citing Commissioner Warning

- 17.35.1 The provisions of Regulation 17.25 shall apply to Temporary Suspensions and Citing Commissioner Warnings in Sevens save as set out below:
- (a) The maximum period of suspension shall not exceed **2 minutes** and does not include half-time for time-keeping purposes. If the period of suspension continues beyond the half-time interval, the suspended Player is not permitted contact with his team.
  - (b) The report which may be in the standard form shall be forwarded to the nominated officer of the Host Union or Tournament Organiser as soon as reasonably practicable and ordinarily within **2 hours** of the completion of the Match in which the Temporary Suspension was imposed.
  - (c) The Host Union or Tournament Organiser shall forward a copy of the report to the relevant parties within **4 hours** of receipt. Such report shall clearly state that the Player has the right to challenge the

Temporary Suspension but if he wishes to do so he must give notice of his challenge within **12 hours** of receipt. Such notice shall be duly recorded by the Host Union or Tournament Organiser and shall be considered in the event of the Player subsequently being involved in any judicial hearing in relation to the accumulation of Temporary Suspensions.

- (d) If the Player wishes to challenge the Citing Commissioner Warning he shall give notice of his intention to challenge within **12 hours** of notification. Such notice shall be duly recorded by the Host Union or Tournament Organiser and shall be considered in the event of the Player subsequently being involved in any judicial hearing in relation to the accumulation of Citing Commissioner Warnings.

17.35.2 (a) A Player who has been Temporarily Suspended and/or received a Citing Commissioner Warning in three or more Matches and/or received a combination of three or more Temporary Suspensions and/or Citing Commissioner Warnings at a single Sevens tournament or Series of Matches or a Player who has been Temporarily Suspended or received a Citing Commissioner Warning (or a combination of both) five times during a season of World Rugby Sevens World Series, shall be required to appear before a Judicial Officer at an appointed time and place.

- (b) Pending such hearing the Player shall not take part in any Match anywhere in the world and shall be suspended from all on-field activities on Match days pending the resolution of the case.

- (c) Ordinarily, such hearings shall take place at the Tournament venue at which the third or fifth Temporary Suspension, Citing Commissioner Warning or combination of both was imposed on the Player. The decision on the appropriate venue for the hearing shall be made by the Judicial Officer.

### 17.36 Appeals

17.36.1 To be valid, any appeal against the decision of a Judicial Officer in Sevens must be lodged with the disciplinary officer (or his nominee) of the Host Union or Tournament Organiser in writing, within **24 hours** of the notification of the decision of the Judicial Officer to the Player or his Union.

17.36.2 Appeals shall ordinarily be heard by an Appeal Officer.

**APPENDIX 1. WORLD RUGBY SANCTIONS FOR FOUL PLAY (REGULATION 17)**

Law No.	Description	Entry Point Based on Scale of Seriousness of the Player's conduct, which constitutes the offending – Lower End (LE), Mid-Range (MR), Top End (TE).	Maximum Sanction
<b>10.4(s)</b> <b>10.4(m)</b>	Verbal Abuse of Match Officials	LE – 6 weeks MR – 12 weeks TE – 18+weeks	52 weeks
<b>10.4(s)</b> <b>10.4(m)</b>	Threatening Actions or Words at Match Officials	LE – 12 weeks MR – 24 weeks TE – 48+ weeks	260 weeks
<b>10.4(s)</b> <b>10.4(m)</b>	Physical Abuse of Match Officials	LE – 24 weeks MR – 48 weeks TE – 96+ weeks	Life
<b>10.4(s)</b> <b>10.4(m)</b>	Incidental Physical Contact with Match Officials	LE – 6 weeks MR – 12 weeks TE – 18+weeks	52 weeks
<b>10.4(a)</b>	Striking another Player with a hand, arm or fist	LE – 2 weeks MR – 4 weeks TE – 8+ weeks  A strike to the head shall result in at least a mid-range entry point sanction.	52 weeks
<b>10.4(a)</b>	Striking another Player with the elbow	LE – 2 weeks MR – 6 weeks TE – 10+ weeks  A strike to the head shall result in at least a mid-range entry point sanction.	52 weeks
<b>10.4(a)</b>	Striking with knee	LE – 4 weeks MR – 8 weeks TE – 12+ weeks  A strike to the head shall result in at least a mid-range entry point sanction.	52 weeks

Law No.	Description	Entry Point Based on Scale of Seriousness of the Player's conduct, which constitutes the offending – Lower End (LE), Mid-Range (MR), Top End (TE).	Maximum Sanction
10.4(a)	Striking with head	LE – 4 weeks MR – 10 weeks TE – 16+ weeks	104 weeks
10.4(b)	Stamping/Trampling on an Opponent	LE – 2 weeks MR – 6 weeks TE – 12+ weeks  Stamping/trampling on the head shall result in a top-end entry point sanction.	52 weeks
10.4(c)	Kicking an Opponent	LE – 4 weeks MR – 8 weeks TE – 12+ weeks  A kick to the head shall result in a top-end entry point sanction.	52 weeks
10.4(d)	Tripping an Opponent with the foot/leg	LE – 2 weeks MR – 4 weeks TE – 8+ weeks	52 weeks
10.4(e)	Dangerous tackling of an Opponent including early or late and including the action known as the “stiff arm tackle”	LE – 2 weeks MR – 6 weeks TE – 10+ weeks	52 weeks
10.4(e)	Dangerous tackling of an Opponent including: (i) a tackle or attempted tackle above the line of the shoulders even if the tackle starts below the line of the shoulders; (ii) grabbing and rolling/twisting around the head/neck area even if the contact starts below the line of shoulders.	LE – 2 weeks MR – 6 weeks TE – 10+ weeks  A dangerous tackle which results in a strike to the head shall result in at least a mid-range entry point sanction.	52 weeks

Law No.	Description	Entry Point Based on Scale of Seriousness of the Player's conduct, which constitutes the offending – Lower End (LE), Mid-Range (MR), Top End (TE).	Maximum Sanction
10.4(f)	Holding, pushing or obstructing an Opponent not holding the ball, by a Player who is not in possession of the ball, except in a scrum, ruck or maul	LE – 2 weeks MR – 4 weeks TE – 6+ weeks	52 weeks
10.4(f) 10.4(k)	Dangerous charging or obstructing or grabbing of Opponent with or without the ball, including shouldering	LE – 2 weeks MR – 6 weeks TE – 10+ weeks	52 weeks
10.4(h)	A player must not charge into a ruck or maul. Charging includes any contact made without use of the arms, or without grasping a player	LE – 2 weeks MR – 6 weeks TE – 10+ weeks	52 weeks
10.4(i)	Tackling, pushing, pulling, colliding with or otherwise making contact with an Opponent who is jumping for the ball in a lineout or in open play where there is no realistic prospect of the player competing for the ball	LE – 4 weeks MR – 8 weeks TE – 12+ weeks	52 weeks
10.4(j)	Lifting a Player from the ground and either dropping or driving that Player's head and/or upper body into the ground whilst the Player's feet are off the ground	LE – 6 weeks MR – 10 weeks TE – 14+ weeks	52 weeks
10.4(k)	Causing a scrum, ruck or maul to collapse	LE – 2 weeks MR – 4 weeks TE – 8+ weeks	52 weeks
10.4(m)	A player must not grab, twist, squeeze or strike an opponent in the genital area (male or female) or, in the case of female players, the breast area.	LE – 12 weeks MR – 18 weeks TE – 24+ weeks	208 weeks
10.4(m)	Biting	LE – 12 weeks MR – 18 weeks TE – 24+ weeks	208 weeks
10.4(m)	Contact with the Eye(s)	LE – 12 weeks MR – 18 weeks TE – 24+ weeks	208 weeks

Law No.	Description	Entry Point Based on Scale of Seriousness of the Player's conduct, which constitutes the offending – Lower End (LE), Mid-Range (MR), Top End (TE).	Maximum Sanction
10.4(m)	Contact with the Eye Area <sup>5</sup>	LE – 4 weeks MR – 8 weeks TE – 12+ weeks	52 weeks
10.4(m)	Spitting at Players	LE – 4 weeks MR – 8 weeks TE – 12+ weeks	52 weeks
10.4(m)	Verbal abuse of Players, Match Officials, spectators, coaches or support staff based on Religion, Race, Colour, or National or Ethnic Origin, sexual orientation or otherwise	LE – 6 weeks MR – 12 weeks TE – 18+ weeks	52 weeks
10.4(m)	Any other acts (not previously referred to) which are contrary to good sportsmanship	LE – 4 weeks MR – 8 weeks TE – 12+ weeks	52 weeks
10.4(m)	Hair pulling or grabbing	LE – 2 weeks MR – 4 weeks TE – 6+ weeks	52 weeks
10.4(m)	Late charging the kicker	LE – 2 weeks MR – 6 weeks TE – 10+ weeks	52 weeks

In respect of offences not referred to in Appendix 1 above, appropriate sanctions may be imposed at the discretion of the relevant Judicial Officer, Disciplinary Committee, Appeal Officer and/or Appeal Committee (as the case may be).

Notwithstanding the Sanctions in Appendix 1 and/or the provisions of Regulation 17.19 in cases where the player's actions constitute mid-range or top end offending for any type of offence which had the potential to result and, in fact, did result in serious/gross consequences to the health of the victim, the Judicial Officers and/or Disciplinary Committees may impose any period of suspension including a suspension for life.

<sup>5</sup>The "eye" involves all tissues including the eye lids within and covering the orbital cavity and the "eye area" is anywhere in close proximity to the eye.





**APPENDIX 2 – FORM 1 STANDARD FORM REFEREE’S REPORT ON AN ORDERING OFF – INTERNATIONAL MATCH**

WORLD RUGBY.

Player’s Union:  Full name of Player:

Venue:  Date of Dismissal:

Player Number:  Playing position:

Match result:   pts   pts

**Nature of offence:**  
(Please circle appropriate offence and give a short description of the Law)

**Infringement of:**

Law 3.11 (c)	Law 4.5 (c)	
Law 10.2 (a) (b) (c)	Law 10.3 (a) (b) (c)	
Law 10.4 (a) (b) (c) (d) (e) (f) (g) (h) (i) (j) (k) (l) (m) (n) (o) (p) (s)		
Other		

PERIOD (of game when incident occurred): 1<sup>st</sup> Half  2<sup>nd</sup> Half  Elapsed time in half

Proximity of referee to incident:  (metres)

Score at that time:  pts  pts

Had any cautions been issued to: a) Individual Yes  No  b) General Yes  No

Was the Player ordered off further to the report of an assistant referee? Yes  No   
(If yes, Form 2 may need to be completed and submitted by the assistant referee)

REFEREE’S NAME: \_\_\_\_\_ UNION: \_\_\_\_\_ Date: \_\_\_\_\_

**Please give detailed report below: PLEASE WRITE CLEARLY**

---

---

---

---

---

---

---

---

---

---

REPORT: - please use paper apart if necessary

THIS REPORT MUST BE COMPLETED AND PROVIDED TO A DESIGNATED DISCIPLINARY OFFICIAL IMMEDIATELY AFTER THE COMPLETION OF THE MATCH

**APPENDIX 2 – FORM 2 STANDARD FORM ASSISTANT REFEREE’S REPORT ON AN ORDERING OFF – INTERNATIONAL MATCH**



WORLD RUGBY

Player’s Union:  Full name of Player:

Venue:  Date of Dismissal:

Player Number:  Playing position:

Match result:   pts   pts

**Nature of offence:** (Please circle appropriate offence and give a short description of the Law)

Infringement of: Law 3.11 (c) Law 4.5 (c)  
 Law 10.2 (a) (b) (c) Law 10.3 (a) (b) (c)  
 Law 10.4 (a) (b) (c) (d) (e) (f) (g) (h) (i) (j) (k) (l) (m) (n) (o) (p) (s)  
 Other

---

PERIOD (of game when incident occurred): 1<sup>st</sup> Half  2<sup>nd</sup> Half  Elapsed time in half

Proximity of Assistant referee to incident:  (metres)

Score at that time:  pts  pts

Had any cautions been issued to: a) Individual Yes  No  b) General Yes  No

ASSISTANT REFEREE’S NAME: \_\_\_\_\_ UNION: \_\_\_\_\_ Date: \_\_\_\_\_

REFEREE’S NAME: \_\_\_\_\_ UNION: \_\_\_\_\_

**Please give detailed report below: PLEASE WRITE CLEARLY**

\_\_\_\_\_

\_\_\_\_\_

\_\_\_\_\_

\_\_\_\_\_

\_\_\_\_\_

*REPORT: - please use paper apart if necessary*

**THIS REPORT MUST BE COMPLETED AND PROVIDED TO A DESIGNATED DISCIPLINARY OFFICIAL IMMEDIATELY AFTER THE COMPLETION OF THE MATCH**



APPENDIX 2 – FORM 3(A) STANDARD FORM CITING COMMISSIONER’S REPORT – INTERNATIONAL MATCH



Player’s Union:  Full name of Player:

Venue:  Date of Incident:

Player Number:  Playing position:

Match result:   pts   pts

**Nature of offence:**  
(Please circle appropriate offence and give a short description of the Law)

Law 10.4 (a) (b) (c) (d) (e) (f) (h) (i) (j) (k) (m) (n) (o) (s)

PERIOD (of game when incident occurred): 1<sup>st</sup> Half  2<sup>nd</sup> Half  Elapsed time in half

Proximity of Official(s) to incident:  (metres)

Score at that time:  pts  pts

Please give detailed report below: **PLEASE WRITE CLEARLY**

REPORT: - *please use paper apart if necessary*

Citing Commissioner

**THIS REPORT MUST BE COMPLETED AND PROVIDED TO A DESIGNATED DISCIPLINARY OFFICIAL PRIOR TO THE EXPIRATION OF THE CITING PERIOD**

**APPENDIX 2 – FORM 3(B) STANDARD FORM CITING COMMISSIONER WARNING – INTERNATIONAL MATCH**

  
WORLD RUGBY

Player's Union:  Full name of Player:

Venue:  Date of Incident:

Player Number:  Playing position:

Match result:   pts   pts

**Nature of offence:**  
(Please circle appropriate offence and give a short description of the Law)

Law 10.4 (a) (b) (c) (d) (e) (f) (h) (i) (j) (k) (m) (n) (o) (s)

PERIOD (of game when incident occurred): 1<sup>st</sup> Half  2<sup>nd</sup> Half  Elapsed time in half

Proximity of Official(s) to incident:  (metres)

Score at that time:  pts  pts

Please give detailed report below: **PLEASE WRITE CLEARLY**

\_\_\_\_\_  
\_\_\_\_\_  
\_\_\_\_\_  
\_\_\_\_\_  
\_\_\_\_\_  
\_\_\_\_\_

REPORT: - please use paper apart if necessary

Citing Commissioner

**THIS REPORT MUST BE COMPLETED AND PROVIDED TO THE DESIGNATED DISCIPLINARY OFFICIAL AND SHALL FORM PART OF THE PLAYERS DISCIPLINARY RECORD**

**NOTE TO PLAYER:** You may challenge this Citing Commissioner Warning within 48 hours of receipt by giving notice to the Designated Disciplinary Official and, ordinarily, specifying reasons









**APPENDIX 2 - FORM 6 WORLD RUGBY SEVENS TOURNAMENTS  
JUDICIAL OFFICER'S HEARING REPORT**

Date of Hearing: \_\_\_\_\_

Name of Unions participating in the Match: \_\_\_\_\_

Date of Match: \_\_\_\_\_

Match Venue: \_\_\_\_\_

Player's Name: \_\_\_\_\_

Player's Union: \_\_\_\_\_

Referee's Name: \_\_\_\_\_

Offence as stated in the Referee's / Citing Commissioner's Report *(please circle as appropriate)*:

\_\_\_\_\_  
\_\_\_\_\_

Judicial Officer's Decision *(please continue on a separate sheet if necessary)*

\_\_\_\_\_  
\_\_\_\_\_  
\_\_\_\_\_  
\_\_\_\_\_  
\_\_\_\_\_  
\_\_\_\_\_  
\_\_\_\_\_  
\_\_\_\_\_  
\_\_\_\_\_  
\_\_\_\_\_

Signature of Judicial Officer: \_\_\_\_\_



## APPENDIX 3. DISCIPLINARY GUIDELINES FOR UNDERAGE GAME

### A. Introduction

These Guidelines have been made available by World Rugby for Unions who wish to implement a specific disciplinary regime at the Underage Game level which reflects the age of the Players, the truncated playing season of such Players and the likelihood for non-Match based sanctions to be imposed in particular for school-boys and girls.

The Disciplinary Guidelines for the Underage Game (the “**Guidelines**”) may be adopted by Unions at their sole election. If adopted, in order to ensure that the principle of universality is maintained the Guidelines must be implemented in their entirety including the application of the World Rugby Sanctions for Foul Play Table adjusted for Underage Rugby contained in the Guidelines.

### 1. Additional Rules in the Underage Game

1.1 Where a Union so elects as part of its rules, the following provisions relating to Discipline for Foul Play in the Underage Game shall apply to Underage Players within its jurisdiction.

1.2 For the purposes of Regulation 17.1.1(a) these Underage Game provisions shall not constitute a breach of Regulation 17. These rules shall replace the equivalent provisions within Regulation 17 to the extent necessary to enable their enforcement.

### 2. Definitions<sup>6</sup>

2.1 “**Constituent Body**” shall mean a Union member or duly recognised entity within the territory of the Union responsible for the running of Matches involving Underage Players and/or participation of Underage Players in the Game and imposition of sanctions in the Underage Game (including primary and second level educational institutions).

2.2 “**Underage Players**” shall mean those players below the Age of Majority at the level of Game below International Match and/or cross-border match level within the territory of the Union. For the avoidance of doubt such provisions shall not apply to any Underage professional, semi-professional or Rugby academy Players or to those playing adult Rugby.

### 3. Disciplinary Personnel

3.1 The Union shall develop and/or approve a process for the appointment by it or its designated Constituent Bodies of suitable and experienced

---

<sup>6</sup> All other definitions in the Guidelines are as per Regulation 1 of the World Rugby Regulations Relating to the Game.

personnel to an Underage disciplinary panel and (where appropriate) an accompanying accreditation system to deal with cases involving Foul Play by Underage Players. Such panel shall comprise persons who can act in a disciplinary and/or appeals capacity.

3.2 The Union and/or its designated Constituent Bodies may appoint a single “**Disciplinary Officer**” (or a Disciplinary Committee) to deal with cases of Foul Play for Underage Players. An appeals process should also be developed.

3.3 All appointees to the Underage disciplinary panel and (where appointed) accredited personnel shall have an in-depth knowledge of the Game and its disciplinary process, be either a lawyer, judge or senior member of an educational institution (such as the principal, vice principal or head teacher), be accustomed to dealing with Underage Players and meet any national imposed criteria for engaging / interacting with Underage Players.

3.4 Neutrality of the appointee(s) to the parties is desirable but can be waived by agreement save where there is a conflict of interest scenario.

3.5 The appointed disciplinary personnel shall carry out their functions in a manner that recognises the following fundamental principles – including the need to ensure:

(a) the provision of a comfortable and safe hearing environment for the Underage Player;

(b) the adoption of a structured but less formal approach to the proceedings;

(c) the adherence to the principles of natural justice which should be made known to the Underage Player (and their representative) at the outset; and

(d) be administered by people who are accustomed to dealing with children.

#### 4. **Sanctioning**

4.1 Where the Guidelines are adopted, the World Rugby Sanctions for Foul Play Adjusted for the Underage Rugby shall apply to all Underage Players. These Sanctions have been established on a per Match basis.

4.2 It is recognised that for Underage Players restorative justice and community sanctions, alongside mentoring, educational development and supervision are all effective mechanisms in dealing with the treatment of breaches for Underage Players. Therefore augmenting playing sanctions with non-playing sanctions for Underage Players is considered appropriate for this age-group.

- 4.3 Disciplinary personnel in the imposition of sanctions for Underage Players may consider the imposition of non-playing sanctions (such as suspension from membership of a team or club or from social activities, loss of privileges, detention etc.) in addition to the World Rugby Sanctions for Foul Play Adjusted for the Underage Rugby.
- 4.4 In terms of the application of Sanctions the following principles apply:
- 4.4.1 The Core Sanctioning Process in Regulation 17.19 shall be followed;
- 4.4.2 Regulation 17.19.5 allows the youth and inexperience of the Player to be taken into account for (off-field) mitigation purposes. In the Underage Game this is particularly pertinent;
- 4.4.3 Regulation 17.19.6 permits up to a maximum of 50% discount on the entry point sanction – this allows great flexibility;
- 4.4.4 Where a matter is determined to be low end offending (following the assessment under Regulation 17.19.2) and there are off field mitigating factors and the sanction would be wholly disproportionate to the level and type of offending involved, in these cases a sanction below 50% of the sanction may apply;
- 4.4.5 Education based sanctions shall be supplemental to the World Rugby Sanctions for Foul Play Adjusted for the Underage Rugby.
- 5. Enforcement**
- 5.1 It is the responsibility of the Union where it introduces these Guidelines to ensure that they are implemented in a consistent and cohesive manner. The Union shall exercise its supervisory jurisdiction in this regard and introduce relevant rules to support such review.
- 5.2 Where a Union implements these Guidelines it shall:
- 5.1.1 so inform World Rugby and provide a copy of the empowering regulations;
- 5.1.2 keep an account (on an annual basis) of the cases and decisions which arise under these Guidelines and make them available to World Rugby upon request;
- 5.1.3 provide suitable educational materials and training to the disciplinary panel (and as applicable accredited) personnel on the implementation of the Guidelines and the application of the disciplinary process.
- 5.3 Any sanctions imposed under the Guidelines for the Underage Game are intended to carry through into adult rugby where applicable.
- 5.4 Where adopted, these Guidelines shall be treated as enforceable by World Rugby in the same way as Regulation 17.

**WORLD RUGBY SANCTIONS FOR FOUL PLAY (REGULATION 17)  
ADJUSTED FOR UNDERAGE RUGBY**

Law No.	Description	Maximum Sanction	Adult Sanction including U20's Entry Point is based on Scale of Seriousness of the Player's conduct, which constitutes the offending - Lower End (LE) Mid-Range (MR) Top End (TE)	Age Grade Sanction to apply based upon matches	
				Up to U15	U16 to U18
10.4(s) 10.4(m)	Verbal Abuse of Match Officials	52 weeks	LE 6 weeks MR 12 weeks TE 18+ weeks	2 4 6+	3 6 9+
10.4(s) 10.4(m)	Threatening Actions or Words at Match Officials	260 weeks	LE 12 weeks MR 24 weeks TE 48+ weeks	3 6 12+	6 12 24+
10.4(s) 10.4(m)	Physical Abuse of Match Officials	Life	LE 24 weeks MR 48 weeks TE 96+ weeks	6 12 24+	12 24 48+
10.4(s) 10.4(m)	Incidental Physical Contact with Match Official	52 weeks	LE 6 weeks MR 12 weeks TE 18+ weeks	2 4 6+	3 6 9+
10.4(a)	Striking another Player with a hand, arm or fist	52 weeks	LE 2 weeks MR 4 weeks TE 8+ weeks A strike to the head shall result in at least a mid-range entry point sanction.	1 2 3+	2 3 5+
10.4(a)	Striking another Player with the elbow	52 weeks	LE 2 weeks MR 6 weeks TE 10+ weeks A strike to the head shall result in at least a mid-range entry point sanction.	1 2 4+	2 5 8+
10.4(a)	Striking with knee	52 weeks	LE 4 weeks MR 8 weeks TE 12+ weeks A strike to the head shall result in at least a mid-range entry point sanction.	2 3 5+	3 4 8+

Law No.	Description	Maximum Sanction	Adult Sanction including U20's	Age Grade Sanction to apply based upon matches	
			Entry Point is based on Scale of Seriousness of the Player's conduct, which constitutes the offending - Lower End (LE) Mid-Range (MR) Top End (TE)	Up to U15	U16 to U18
10.4(a)	Striking with head	104 weeks	LE 4 weeks MR 10 weeks TE 16+ weeks	2 4 6+	4 6 10+
10.4(b)	Stamping/Trampling on an Opponent	52 weeks	LE 2 weeks MR 6 weeks TE 12+ weeks Stamping/trampling on the head shall result in a top-end entry point sanction.	1 2 5+	2 5 10+
10.4(c)	Kicking an Opponent	52 weeks	LE 4 weeks MR 8 weeks TE 12+ weeks A kick to the head shall result in a top-end entry point sanction.	2 4 6+	4 6 10+
10.4(d)	Tripping an Opponent with the foot/leg	52 weeks	LE 2 weeks MR 4 weeks TE 8+ weeks	1 2 3+	2 3 5+
10.4(e)	Dangerous tackling of an Opponent including early or late and including the action known as the "stiff arm tackle"	52 weeks	LE 2 weeks MR 6 weeks TE 10+ weeks	1 2 4+	2 5 8+
10.4(e)	Dangerous tackling of an Opponent including: (i) a tackle or attempted tackle above the line of the shoulders even if the tackle starts below the line of the shoulders; (ii) grabbing and rolling/twisting around the head/neck area even if the contact starts below the line of shoulders.	52 weeks	LE 2 weeks MR 6 weeks TE 10+ weeks A dangerous tackle which results in a strike to the head shall result in at least a mid-range entry point sanction.	1 2 4+	2 5 8+
10.4(f)	Holding, pushing or obstructing an Opponent not holding the ball, by a Player who is not in possession of the ball, except in a scrum, ruck or maul	52 weeks	LE 2 weeks MR 4 weeks TE 6+ weeks	1 2 3+	2 3 5+

Law No.	Description	Maximum Sanction	Adult Sanction including U20's Entry Point is based on Scale of Seriousness of the Player's conduct, which constitutes the offending - Lower End (LE) Mid-Range (MR) Top End (TE)	Age Grade Sanction to apply based upon matches	
				Up to U15	U16 to U18
10.4(f) 10.4(k)	Dangerous charging or obstructing or grabbing of Opponent with or without the ball, including shouldering	52 weeks	LE 2 weeks MR 6 weeks TE 10+ weeks	1 2 4+	2 5 8+
10.4(h)	A player must not charge into a ruck or maul. Charging includes any contact made without use of the arms, or without grasping a player	52 weeks	LE 2 weeks MR 6 weeks TE 10+ weeks	1 2 4+	2 5 8+
10.4(i)	Tackling, pushing, pulling, colliding with or otherwise making contact with an Opponent who is jumping for the ball in a lineout or in open play where there is no realistic prospect of the player competing for the ball	52 weeks	LE 4 weeks MR 8 weeks TE 12+ weeks	2 4 6+	4 6 10+
10.4(j)	Lifting a Player from the ground and either dropping or driving that Player's head and/or upper body into the ground whilst the Player's feet are off the ground	52 weeks	LE 6 weeks MR 10 weeks TE 14+ weeks	2 4 6+	5 8 14+
10.4(k)	Causing a scrum, ruck or maul to collapse	52 weeks	LE 2 weeks MR 4 weeks TE 8+ weeks	Warning <sup>7</sup> 1 2+	1 2 3+
10.4(m)	A player must not grab, twist, squeeze or strike an opponent in the genital area (male or female) or, in the case of female players, the breast area	208 weeks	LE 12 weeks MR 18 weeks TE 24+ weeks	3 6 12+	6 12 18+
10.4(m)	Biting	208 weeks	LE 12 weeks MR 18 weeks TE 24+ weeks	3 6 12+	6 12 18+
10.4(m)	Contact with the Eye(s)	208 weeks	LE 12 weeks MR 18 weeks TE 24+ weeks	3 6 12+	6 12 18+
10.4(m)	Contact with the Eye Area <sup>8</sup>	52 weeks	LE 4 weeks MR 8 weeks TE 12+ weeks	2 4 6+	4 6 10+
10.4(m)	Spitting at Players	52 weeks	LE 4 weeks MR 8 weeks TE 12+ weeks	2 4 6+	4 6 10+

<sup>7</sup> A Warning shall form part of the Players disciplinary record while at Underage level but not extend into their senior disciplinary record.

<sup>8</sup> The "eye" involves all tissues including the eye lids within and covering the orbital cavity and the "eye area" is anywhere in close proximity to the eye.

Law No.	Description	Maximum Sanction	Adult Sanction including U20's	Age Grade Sanction to apply based upon matches	
			Entry Point is based on Scale of Seriousness of the Player's conduct, which constitutes the offending - Lower End (LE) Mid-Range (MR) Top End (TE)	Up to U15	U16 to U18
<b>10.4(m)</b>	Verbal abuse of Players, Match Officials, spectators, coaches or support staff based on Religion, Race, Colour, or National or Ethnic Origin, sexual orientation or otherwise	<b>52 weeks</b>	LE 6 weeks MR 12 weeks TE 18+ weeks	2 4 6+	4 8 12+
<b>10.4(m)</b>	Any other acts (not previously referred to) which are contrary to good sportsmanship	<b>52 weeks</b>	LE 4 weeks MR 8 weeks TE 11+ weeks	2 4 6+	4 6 10+
<b>10.4(m)</b>	Hair pulling or grabbing	<b>52 weeks</b>	LE 2 weeks MR 4 weeks TE 6+ weeks	1 2 3+	2 3 5+
<b>10.4(o)</b>	Late charging the kicker	<b>52 weeks</b>	LE 2 weeks MR 6 weeks TE 10+ weeks	1 2 4+	2 5 8+

## APPENDIX 4. SANCTIONS GUIDANCE FOR ACCUMULATION OF TEMPORARY SUSPENSIONS AND/OR CITING COMMISSIONER WARNINGS

1. There is deliberately no guidance within the World Rugby sanctions table(s) to assist a Judicial Officer or Judicial Committee to determine the appropriate sanction in relation to accumulated Temporary Suspensions and/or Citing Commissioner Warnings. This is an area where judicial discretion is required given the multiple permutations that could emerge. A Judicial Officer or Judicial Committee may be required to consider whether to apply sanctions against Players for accumulation of Temporary Suspensions and/or Citing Commissioner Warnings in two circumstances:
  - (a) where a Player has received three Temporary Suspensions and/or Citing Commissioner Warnings (or a combination thereof) in a particular tournament or series and/or five Temporary Suspensions and/or Citing Commissioner Warnings in a season of the World Rugby Sevens Series and the Judicial Officer or Judicial Committee is required to consider whether any further penalty should be imposed by reason of his persistent Foul Play (Regulations 17.25.2(d), 17.25.3(d) and 17.35.2(a)); or
  - (b) where a Player has received two Temporary Suspensions and/or Citing Commissioner Warnings in one Match which in the case of a Temporary Suspension led to him being Ordered Off on receipt of the second temporary suspension (Regulation 17.25.3(b)).
2. It is assumed for the purposes of this Appendix that none of the relevant Temporary Suspensions resulted in a subsequent citing which was upheld by a Judicial Officer. In such cases the Temporary Suspension event which has been cited falls away and is replaced by the decision arising from the citing.
  - A. Player receives three Temporary Suspensions and/or Citing Commissioner Warnings in a Tournament/Series or five in a Sevens Series**
    1. The Judicial Officer or Judicial Committee is required to apply a sanction for the offence of persistent offending, not for the substantive offences relating to each Temporary Suspension and/or Citing Commissioner Warning. Ordinarily, the appropriate entry point sanction in such circumstances is a suspension of one to three weeks depending upon the seriousness of the offending. Sanctioning in these circumstances should be determined by reference to the methodology in Regulation 17.19 and in particular to the application of mitigating and aggravating features.
    2. The Judicial Officer or Judicial Committee may, however, decide to apply no sanction in the following circumstances:
      - (a) where one or more of the Temporary Suspensions and/or Citing Commissioner Warnings was applied as a result of mistaken identity; or
      - (b) exceptional circumstances exist which would warrant no sanction being imposed. This situation could arise when:



- (i) a Player was temporarily suspended for an act of Foul Play but on review it was clear that there was no Foul Play or only a minor act of Foul Play had been committed which would not have warranted a Temporary Suspension or Citing Commissioner Warning;
- (ii) some of the Temporary Suspensions were awarded for technical offences (that is, not Foul Play) following a team warning by the referee or for what are characterised as so called technical offences not involving a breach of Law 10.4.

**B. Player receives two Temporary Suspensions/Citing Commissioner Warnings in one Match**

1. The Judicial Officer or Judicial Committee is required to apply a sanction for the offence of persistent offending, not for the substantive offences relating to each Temporary Suspension and/or Citing Commissioner Warning. Ordinarily, the appropriate entry point for persistent offending within a single Match is a suspension of one to two weeks. Sanctioning in these circumstances should be determined by reference to the methodology in Regulation 17.19 and in particular to the application of mitigating and aggravating features.
2. The Judicial Officer or Judicial Committee may decide that sending off was sufficient (or otherwise that no further sanction is appropriate) in the following circumstances:
  - (a) where either of the Temporary Suspensions or Citing Commissioner Warnings was applied as a result of mistaken identity; or
  - (b) that exceptional circumstances exist which would warrant no further sanctions being imposed. This situation could arise when a Player was temporarily suspended for an act of Foul Play but on review it was clear that there was no Foul Play or only a minor act of Foul Play had been committed which would not have warranted a Temporary Suspension and/or Citing Commissioner Warning;
  - (c) any of the Temporary Suspensions were awarded for so-called technical offences (including following a team warning) not involving a breach of Law 10.4.



**REGULATION 18. DISCIPLINARY AND JUDICIAL MATTERS****18.1 Breach of the Bye-Laws or Regulations**

18.1.1 A Union or Association shall be subject to sanction by a Judicial Officer or Judicial Committee if it is found to have breached the Bye-Laws or Regulations or to have:

- (a) brought World Rugby or the Game or any Person into disrepute;
- (b) engaged in conduct, behaviour or practice(s) which may be prejudicial to the interests of World Rugby or of the Game;
- (c) disclosed any confidential information obtained through connection with the Game;
- (d) breached the Code of Conduct; or
- (e) breached the Wagering Regulations (Regulation 6).

18.1.2 A Rugby Body, Club or Person that contravenes these Regulations, brings World Rugby or the Game into disrepute, engages in conduct, behaviour or practices which may be prejudicial to the interests of World Rugby or the Game, discloses any confidential information obtained through connection with the Game, or which breaches the Code of Conduct shall be subject to sanction by the Union or Association having jurisdiction in respect thereof in accordance with the bye-laws regulations, code of conduct or other undertakings or agreements of that Union or Association.

18.1.3 A Person shall be subject to sanction by a Judicial Committee or Judicial Officer appointed by World Rugby if he breaches the World Rugby Code of Conduct and/or brings World Rugby or the Game into disrepute, and/or engages in conduct, behaviour or practices which may be prejudicial to the interests or image of World Rugby or the Game, and/or discloses any confidential information obtained through his connection with the Game, in accordance with these Regulations.

18.1.4 A Player shall be subject to sanction by a Judicial Committee or Judicial Officer appointed by World Rugby if he breaches Regulation 8.

**18.2 The Appointment and Functions of Judicial Officers and Judicial Committees**

18.2.1 The Council shall appoint a panel of individuals (“the Judicial Panel”) of such number as the Council shall think fit, each of whom shall be eligible to sit as Judicial Officers and/or as Members of Judicial Committees. The Council shall appoint a chairman of the Judicial Panel. The Chairman of the Judicial Panel (or his designee) shall, in consultation with the Chairman of the Council, or his nominee, appoint individual Judicial Officers or Judicial Committees from members of the Judicial Panel to resolve, hear and adjudicate on the following:

- (a) an alleged breach(es) of the Bye-Laws and/or the Regulations and/or alleged offences under Regulation 18.1.1 and/or 18.1.3;
- (b) disputes arising under Regulation 4;
- (c) disciplinary matters arising out of Foul Play and/or Misconduct (Regulation 17 and Regulation 20); and
- (d) such other matters as the Council, Chairman of the Judicial Panel or CEO may from time to time refer to a Judicial Officer or Judicial Committee for adjudication.

18.2.2 Members of the Judicial Panel shall be appointed for a period of up to two years, following which they shall, unless re-appointed by the Council, automatically cease to be a member of the Judicial Panel. The Council may, at its discretion, remove any member of the Judicial Panel, at any time. The decision of the Council shall be final and binding.

18.2.3 Council members appointed as members of the Judicial Panel shall not cease to be members of the Judicial Panel if, during the period of appointment as a Judicial Panel member, they cease to be a member of the Council.

18.2.4 When a Judicial Committee is appointed to adjudicate on a case it shall, ordinarily, be made up of three members of the Judicial Panel, one of whom shall be nominated to act as Chairman of the Committee. The Chairman of the Judicial Panel shall, however, in any case, be entitled, at his discretion, to appoint a Judicial Committee of such number as he considers appropriate, up to a maximum of 5 and a minimum of 2.

18.2.5 Judicial Officers or Judicial Committee members shall not have had any personal involvement with any case referred to them for adjudication or any connection with any of the parties involved in such matter.

18.2.6 If a Judicial Officer or member of a Judicial Committee having been appointed to deal with a case is unable or unwilling to adjudicate then the Judicial Panel Chairman may; (1) appoint another member of the Judicial Panel as a replacement; or (2) appoint a new Judicial Committee; or (3) allow the remaining Judicial Committee members to proceed and adjudicate on the case.

18.2.7 The Chairman of the Judicial Panel shall have the power, exercisable in his discretion, to co-opt from time to time additional persons with specialist skills and experience to sit as Judicial Officers and/or as members of a Judicial Committee to deal with cases that require such specialist skills and experience whether such persons are members of the Judicial Panel or not.

### **18.3 The Appointment and Functions of Appeal Committees**

18.3.1 The Council shall appoint a panel of individuals of such number as the Council thinks fit ("the Appeal Panel"), each of whom shall be eligible to sit as members of Appeal Committees. The Council shall appoint a Chairman

of the Appeal Panel. Members of the Appeal Panel shall not be current members of the Council or any other World Rugby standing committee.

- 18.3.2 Members of the Panel shall include the following:
- (a) Senior legal practitioners with previous experience of judicial proceedings in rugby. Such legal practitioners shall be appointed to sit as Chairmen of Appeal Committees.
  - (b) Eminent rugby administrators, rugby players, coaches and officials with previous experience of judicial proceedings in rugby.
  - (c) Such other individuals as the Council may consider appropriate.
- 18.3.3 The functions of Appeal Committees shall be to hear and decide appeals from decisions made by Judicial Officers or Judicial Committees. The Chairman of the Appeal Panel shall appoint Appeal Committees from Appeal Panel members to hear such appeals.
- 18.3.4 Members of the Appeal Panel shall be appointed for a period of up to two years, following which they shall, unless re-appointed by the Council, automatically cease to be a member of the Appeal Panel. The Council may, at its discretion, remove any member of the Appeal Panel, at any time. The decision of the Council shall be final and binding.
- 18.3.5 When an Appeal Committee is appointed to adjudicate on a case it shall, ordinarily, be made up of three members of the Appeal Panel, one of whom shall be nominated to act as Chairman of the Appeal Committee. The Chairman of the Appeal Panel shall be entitled, however, at his discretion to appoint Appeal Committees of such number as he considers appropriate, up to a maximum of 5 and a minimum of 2.
- 18.3.6 If a member of an Appeal Committee having been appointed to deal with a case, is unable or unwilling to adjudicate then the Appeal Panel Chairman may: (1) appoint another member of the Appeal Panel as a replacement; or (2) appoint a new Appeal Committee; or (3) allow the remaining Appeal Committee members to proceed and adjudicate on the appeal.
- 18.3.7 The Chairman of the Appeal Panel shall have the power, exercisable in his discretion, to co-opt from time to time additional persons with specialist skills and experience to sit as Appeal Committee Members to deal with cases that require such specialist skills and experience whether such persons are members of the Appeals Panel or not.
- 18.4 Procedures Relating to a Breach of the Regulations or Bye-Laws, or Offences under Regulation 18.1.1(a) to (e)**
- 18.4.1 A Union or Association must, as soon as is reasonably practicable, investigate each and every alleged breach of the Regulations occurring or committed within or relating to its jurisdiction and of which it has knowledge. Following such investigation, it shall take such action as is appropriate and thereafter report its decision and the procedures adopted

to the CEO in writing within 28 days of its decision. The CEO shall submit the report to the Council.

- 18.4.2 In the event of the Council and/or CEO not being satisfied with the procedures adopted and/or decision reached by a Union or Association pursuant to Regulation 18.4.1 or in the event of a failure to investigate by that Union or Association, then the Council and/or CEO may refer the matter, via the Judicial Panel Chairman, or his designee to a Judicial Officer or Judicial Committee or take such other action as it deems appropriate.
- 18.4.3 A Union or Association which considers another Union or Association to have so conducted itself as to be in breach of these Regulations or the Bye-Laws or to have committed an offence under Regulation 18.1.1(a) to (e), may make complaint of such conduct to the CEO. To be valid, such complaint must be made in writing, set out full details of the complaint and should be received by the CEO not later than 28 days following the complainant Union or Association having knowledge of the said conduct. Upon receipt of any such complaint, the CEO shall initiate an enquiry into the matter and/or refer the complaint via the Judicial Panel Chairman, or his designee to a Judicial Officer or Judicial Committee for adjudication.
- 18.4.4 The Council or CEO may, whether at the request of a Union, Association, or of its own motion, initiate an enquiry into any alleged, or apparent breach of the Bye-Laws and/or Regulations or alleged offences under Regulation 18.1.1(a) to (e). Such enquiry shall be carried out by the CEO or his designee(s). The procedure for such enquiry shall be determined by the CEO. At the conclusion of any such enquiry, the CEO shall either submit a report to Council or refer the matter, via the Judicial Panel Chairman, or his designee, to a Judicial Officer or Judicial Committee for adjudication. The Council on receipt of the report may refer the matter via the Judicial Panel Chairman, or his designee, to a Judicial Officer or Judicial Committee or take such other action (if any) as is deemed appropriate.

## **18.5 Referral to Judicial Officers or Judicial Committees**

- 18.5.1 Where a matter is referred to a Judicial Officer or Judicial Committee, the Judicial Officer or Judicial Committee shall, subject to Appendix 1, be entitled to deal with the matter procedurally as it considers appropriate provided that the parties concerned are aware of the case against them and are afforded a reasonable opportunity to make representations and present their case. For the avoidance of doubt, World Rugby shall have the right to be represented and shall be entitled through its nominated representative to make submissions during any proceedings conducted by Judicial Officers or Judicial Committees.
- 18.5.2 The decisions of Judicial Committees shall be made by majority. In the event of an even vote, the Chairman of the Judicial Committee shall have a casting vote.

18.5.3 All Judicial Committee members must take part in the deliberations of the committee and no member of a Judicial Committee may abstain.

18.5.4 The decision of the Judicial Officer or Judicial Committee shall, subject to the right of appeal under Regulation 18.7, be final and binding. Any punishment or penalty imposed by a Judicial Officer or Judicial Committee shall not, ordinarily, take effect until the period allowed for an appeal in Regulation 18.7.2 has elapsed or the appeal has been determined. The decision of the Judicial Officer or Judicial Committee may be published by World Rugby.

### **18.6 Penalties**

18.6.1 Upon finding a breach of the Bye-Laws and/or Regulations, or that an offence pursuant to Regulation 18.1.1(a) to (e) inclusive has been committed, Judicial Officers and Judicial Committees shall be entitled to impose such penalties as they think fit. Such penalties may include, but shall not be limited to:

- (a) a caution, warning as to future conduct, reprimand and/or a fine;
- (b) a suspension for a specified number of Matches and/or a specified period; a requirement that a Match or Matches be played with the exclusion of the public; the cancellation of a Match result and, where appropriate, the replaying of a Match; the forfeiture of a Match or matches and/or tie(s); the deduction or cancellation of points; the immediate or future expulsion or suspension from a tournament(s) or competition(s); or any such similar sanctions;
- (c) cancellation or refusal of the registration of any Person registered in contravention of the Regulations;
- (d) a recommendation to the Council that a Union or Association be expelled or suspended from Membership of World Rugby. Subject to the provisions of Bye-Law 6(d), only the Council shall be competent to expel or suspend a Union or Association and any such expulsion or suspension shall only have effect if approved by a two-thirds majority of the votes cast at a properly convened and quorate Council meeting;
- (e) an order that any Union, Association, Rugby Body, Club or Person pay compensation and/or restitution;
- (f) the withdrawal of other benefits or membership of World Rugby, including, but not limited to, the right to apply to host International Tournaments; and
- (g) any combination of the penalties set out in 18.6.1(a) to (f) above.

18.6.2 Judicial Officers and Judicial Committees shall be entitled to make such order in relation to cost as is deemed appropriate;

18.6.3 In determining the appropriate penalty under these Regulations, a Judicial Officer or Judicial Committee shall be entitled to take account of mitigating and/or aggravating circumstances. Aggravating circumstances shall include, but shall not be limited to, the repetition of a breach of a particular Bye-Law or Regulation.

## **18.7 Appeals**

18.7.1 A Union or Association, or World Rugby (through the Executive Committee or CEO), may appeal against the decision of a Judicial Officer or Judicial Committee, against the penalty imposed and/or any costs order. To be valid, any such appeal, together with the written grounds of appeal, must be lodged with the Appeal Panel Chairman, or his designee, within 14 days of the date of the written decision of the Judicial Officer or Judicial Committee.

18.7.2 On receipt of a notice of appeal and the grounds for appeal within the time limit set out in Regulation 18.7.1, an Appeal Committee shall be appointed by the Appeal Panel Chairman or his designee. The Appeal Committee shall, ordinarily, be made up of three members of the Appeal Panel, under the Chairmanship of a senior legal practitioner who shall, subject to Regulation 18.7.3 and Appendix 2, have the discretion to regulate the procedure prior to and at any Appeal Committee hearing.

18.7.3 The Appeal Committee shall determine the basis on which an appeal will proceed, including the standard of review and may, in its discretion rehear the whole or any part of the evidence given before the Judicial Officer or Judicial Committee (as the case may be) as it considers appropriate. For the avoidance of doubt World Rugby shall have the right to be represented and shall be entitled through its nominated representative to make submissions in any proceedings conducted by Appeal Committees.

18.7.4 The Appeal Committee shall have full discretionary power to hear and receive such further evidence as it thinks fit, provided it is established by the appellant that such evidence was not, on reasonable enquiry, available at the time of the original hearing.

18.7.5 For appeal hearings procedural matters shall be determined by the Appeals Committee Chairman. Decisions of the Appeals Committee shall be made by majority. In the event of an even vote, the Chairman of the Appeal Committee shall have a casting vote. No member of an Appeal Committee may abstain and all members of the Committee must take part in its deliberations.

18.7.6 Where an appeal relates to a recommendation by a Judicial Officer or Judicial Committee that a Union or Association be expelled or suspended from membership of World Rugby, the appeal will be heard by the Council. In the event of such an appeal, a meeting of the Council shall be convened by the CEO as soon as reasonably practicable. The procedures on any such appeal, including, but not limited to, the standard of review shall be determined by the Council. The Council may confirm the suspension or expulsion and/or impose such other punishment or



penalties as it considers fit. The decision of the Council shall be made by a two-third majority of members present and shall be final and binding. The decision of the Council shall be effective immediately on written notification to the Union or Association concerned.

## **18.8 Powers of Appeal Committees**

18.8.1 An Appeal Committee shall have the power to:

- (a) allow or re-affirm, or dismiss the appeal;
- (b) vary the decision in such manner as it shall think fit (including power to reduce, uphold, decrease or cancel any penalty);
- (c) make such further order (in relation to costs or otherwise) as it thinks fit; and
- (d) take any other step which in the exercise of its discretion the Appeals Committee considers it would be appropriate to take in order to deal justly with the case in question.

## **18.9 Notification of Appeal Committee Decision**

18.9.1 The parties to the appeal shall be notified in writing as soon as reasonably practicable following the conclusion of the hearing. On notification to the Union or Association the decision shall be final and binding. The decision of the Appeal Committee may be published.

## **18.10 Procedures Relating to Disputes over Player Status, Player Contracts and Player Movement<sup>1</sup>**

18.10.1 Disputes arising out of those matters referred to in Regulation 4 may be referred, by Unions or Associations only, to the CEO who shall, via the Judicial Panel Chairman or his designee, refer such disputes to a Judicial Officer or Judicial Committee for adjudication. The Judicial Officer or Judicial Committee appointed shall, subject to Appendix 1, have the discretion to determine the procedures to be adopted prior to and at any hearing in connection with such a dispute. The decision of the Judicial Officer or Judicial Committee shall be binding on the Union, Association, Person, Club or other Rugby bodies who are parties to the dispute upon receipt of notification of the Judicial Officer's or Judicial Committee's decision.

18.10.2 An appeal against the decision of a Judicial Officer or Judicial Committee in relation to the issues referred to in 18.10.1 above may be lodged with the Appeal Panel Chairman in accordance with Regulation 18.7. The Appeal Panel Chairman shall refer the matter to an Appeal Committee for final and binding adjudication.

---

<sup>1</sup> *Disputes arising out of Regulation 4 will, preferably, be adjudicated on by members of the Judicial Panel who are experienced in player issues including, but not limited to, training and development, and may include eminent ex-players.*

- 18.11 General Procedures relating to proceedings of Commissioners, Judicial Officers, Judicial Committees, Disciplinary Committees, Appeal Committees and Appeal Tribunals**
- 18.11.1 The general procedures to be applied by Commissioners, Judicial Officer(s), Judicial Committees, Disciplinary Committees and Appeal Committees and Appeal Tribunals are set out in Appendix 1.
- 18.11.2 The Council may prescribe additional regulations for the conduct of Commissioners, Judicial Officer(s), Judicial Committees, Disciplinary Committees, Appeal Committees, Appeal Tribunals and may from time to time vary, revoke or replace any such regulations.
- 18.11.3 In respect of any matter not provided for in this Regulation 18 the appropriate body shall take a decision according to general principles of justice and fairness.

**APPENDIX 1. PROCEDURES AND POWERS OF JUDICIAL OFFICERS, JUDICIAL COMMITTEES, DISCIPLINARY COMMITTEES, APPEAL COMMITTEES AND APPEAL OFFICERS ("DISCIPLINARY TRIBUNAL") IN CONNECTION WITH JURISDICTION, PROCESS AND EVIDENTIAL MATTERS RELATING TO HEARINGS.**

**1. General**

- 1.1 Disciplinary Tribunals constituted under these Regulations shall exercise their functions independently, including independently of (i) the parties to the Match and/or proceedings, (ii) the Unions, Associations or Rugby Bodies under whose jurisdiction responsibility falls for the relevant Match and shall not perform a legislative role in any Union, Association or Rugby Body involved in the Match and/or proceedings.
- 1.2 Disciplinary Tribunals shall be fully autonomous and, in particular, any decision they make shall be binding on the Player, Person, his/their national Union(s), Rugby Body(ies) and all other Unions, Associations, Tournament Organisers and their constituent bodies, none of whom shall have the power to affirm, revoke or alter any decision.
- 1.3 The standard of proof on all questions to be determined by Disciplinary Tribunals shall be the balance of probabilities unless otherwise specified in a particular Regulation. Disciplinary Tribunals shall have no discretion in this regard.
- 1.4 Unions, Associations and Disciplinary Tribunals shall be entitled to publish as they think fit reports of their proceedings, findings and penalties and in the case of such bodies appointed by World Rugby, such publication shall be made through World Rugby. No member of a Disciplinary Tribunal shall comment to the media on a decision of that body.
- 1.5 Disciplinary Tribunals shall have absolute discretion in imposing orders as to the payment of costs in relation to any proceedings including the cost of holding the hearings, interpretation and legal costs, travel and accommodation costs of the members of the Disciplinary Tribunals and/or any other expenses necessary for the proper conduct of the hearing.
- 1.6 All hearings shall take place in private.
- 1.7 Disciplinary Tribunals:
- (a) shall be entitled to adjourn and/or postpone proceedings;
  - (b) shall be entitled to determine whether witnesses that give evidence are able to remain within the room in which the matter is being heard after their evidence has been given;

- (c) may direct that an interpreter be present to partake in the proceedings;
  - (d) shall be entitled to call on experts to provide specialist advice;
  - (e) shall be entitled to be assisted by a legal advisor;
  - (f) shall deliberate in private on their decisions.
- 1.8 The non-attendance of a party at a hearing and/or preliminary hearing in respect of which that party has received notice shall not prevent the matter being dealt with in their absence.
- 1.9 A decision of a Judicial Committee, Disciplinary Committee or Appeal Committee shall be valid if taken by at least a simple majority of the members of the Committee. No member of the Judicial, Disciplinary or Appeal Committee may abstain from any decision. Where a Committee has an even number of members and they are unable to reach a unanimous or majority decision then the Chairman of the Judicial, Disciplinary or Appeal Committee shall have a casting vote.
- 1.10 Any procedures, findings or decisions of Disciplinary Tribunals pursuant to disciplinary processes under these Regulations shall not be quashed or invalidated by reason only of any departure from the procedural Regulations, defect, irregularity, omission or other technicality unless such departure, defect, irregularity, omission or technicality raises a material doubt as to the reliability of the findings or decisions of these bodies or results in a miscarriage of justice.
- 1.11 Hearings by Disciplinary Tribunals shall, unless otherwise specified in the Regulations, ordinarily be heard in the country where the disciplinary proceedings originated or at a convenient venue nominated by World Rugby, Host Union or Tournament Organiser as appropriate. In appropriate circumstances technology may be employed to assist the process.
- 1.12 Hearings by Disciplinary Tribunals (save for private deliberations) may be fully audio or audio-visually recorded or by a stenographer. The record of proceedings and all papers associated with the proceedings shall be held for a suitable period by World Rugby, Union or Tournament Organiser under whose jurisdiction the hearing took place and who shall promptly make the same available to World Rugby if it requires.
- 1.13 In respect of any matter not provided for in this Regulation 18, Appendix 1, the appropriate body or person shall take a decision according to general principles of natural justice and fairness.

## 2. **Judicial Committees<sup>2</sup> and Judicial Officers - Power to Regulate their Own Procedures**

2.1 The procedure of Judicial Committees or Judicial Officers in all proceedings shall be as the appointed Judicial Committee or Judicial Officer shall determine in each case. However, subject to the power to regulate its own procedures, it shall:

- (a) seek to conform generally with the procedures set out in Section 1 above, this Section 2 and Section 3 below; and
- (b) ensure that a Player and/or Person subject to disciplinary proceedings has a reasonable opportunity to be heard and be informed of the charge(s) and to present his case.

2.2 The Chairman of the Judicial Committee and the Judicial Officer shall be entitled to determine pre-hearing procedural and/or evidential matters. Such matters may include:

- (a) a pre-hearing conference convened for the purposes of giving directions for the hearing and clarification of the procedures; and
- (b) the requirement for any person to attend the hearing as a witness.

For the purposes of pre-hearing case management the Chairman of the Judicial Committee may exercise this function without reference to the other Judicial Committee members.

2.3 The Judicial Committee or Judicial Officer shall endeavour to ensure that disciplinary proceedings are heard in the presence of the Union, Player and/or Person who is the subject of the proceedings. Nothing in the Regulations, or otherwise, shall prevent a Judicial Committee or Judicial Officer hearing and determining disciplinary proceedings in their absence where the Union, Player and/or Person concerned (and/or their representatives) do not attend the hearing. However hearings may only be held in the absence of any of the parties if those parties have first been given the opportunity to attend and have declined the opportunity without reasonable excuse or consented to a hearing in absentia. In such circumstances the Judicial Committee or Judicial Officer may take any written representations into account in making its decision.

2.4 If a member of a Judicial Committee or a Judicial Officer is unwilling or unable, for whatever reason, to hear the matter referred to them then World Rugby, Host Union or Tournament Organiser may, at its discretion:

- (a) appoint another member to the Judicial Committee as a replacement;
- (b) appoint a new Judicial Officer or appoint a new Judicial Committee;

---

<sup>2</sup> For convenience, only Judicial Committee is referred to but the term also encompasses Disciplinary Committees established for the purposes of Regulations 17.

- (c) allow the remaining members of the Judicial Committee to hear the matter; or
- (d) appoint a Judicial Officer to take the place of the Judicial Committee.

2.5 Where a disciplinary hearing is pending, a Player may, prior to the hearing, be required by the Judicial Committee or Judicial Officer to:

- (a) supply it or him with full particulars of the case that will be presented on the Player's behalf at the hearing and any witnesses intended to be called by the Player;
- (b) provide it or him with copies of any documents or reports that may be relied on by the Player at the hearing; and
- (c) comply with such directions as shall be considered appropriate by the Judicial Committee or Judicial Officer at, or prior to, the hearing.

### **3. Judicial Committee and Judicial Officer - General Procedures**

3.1 The general procedures relating to proceedings of Disciplinary Tribunals set out in Sections 1 and 2 above shall apply.

3.2 Any Union, Player, Person and/or Connected Person who is required to attend a hearing to answer charges or allegations shall be entitled to be represented at the hearing including by a Union representative and/or by legal counsel.

#### **Evidence**

3.3 The Judicial Committee or Judicial Officer shall be entitled to receive such evidence and in such form as it thinks fit (including evidence in writing), notwithstanding the evidence may not be legally admissible and shall be entitled to attach such weight to that evidence as it/he sees fit.

3.4 First-hand accounts from persons present at the hearing as to their observations of the incident in question are to be preferred. Hearsay evidence may be accepted. However, caution will be exercised before hearsay evidence is accepted in preference to first hand evidence and generally less weight is likely to be given to hearsay evidence.

3.5 Judicial Committees or Judicial Officers should not permit the introduction of opinion evidence other than expert opinion evidence. Expert opinion evidence is only likely to be permitted when the evidence falls outside the everyday knowledge of members of the Judicial Committee or of the Judicial Officer.

3.6 Where a direction is given by a Judicial Committee or Judicial Officer it shall be the responsibility of the Union, the Player, Person or witness concerned to ensure that it is complied with, notwithstanding any travel or other arrangements that may need to be made and/or altered. In any case where a direction given by the Judicial Committee or Judicial Officer is not complied with, the Judicial Committee or Judicial Officer may refuse to

allow the evidence of the Union, Player or Person or witness to be given in any other form.

- 3.7 The Judicial Committee or Judicial Officer may direct that the Union or Tournament Organiser be represented. If so, the Union or Tournament Organiser shall appear by counsel and/or by a representative at the hearing, in such capacity as the Judicial Committee or Judicial Officer requires, to provide assistance to the Judicial Committee or Judicial Officer in the discharge of its duties.
- 3.8 Offences and breaches of Regulations may be established by any reliable means, including admissions. The following rules of proof shall be applied by the Judicial Committee or Judicial Officer:
- (a) they shall have the discretion to accept any facts established by a decision of a court of competent jurisdiction or professional disciplinary tribunal which is not the subject of a pending appeal as irrefutable evidence against the Player or Person to whom the decision relates of those facts, save only where the Player or Person establishes that the decision was contrary to the principles of natural justice; and
  - (b) where the Player or Person is charged with an offence and/or breach and fails or refuses without compelling justification to appear at a hearing (in person or by telephonic means) of which they have been given reasonable notice, the Judicial Committee or Judicial Officer may draw an inference adverse to the Player or Person.
- 3.9 Unless it otherwise directs, the procedure of the Judicial Committee or Judicial Officer at a hearing will be as follows:
- (a) the Chairman or Judicial Officer will explain the procedure to be followed;
  - (b) for cases involving Misconduct or breaches of the Code of Conduct and/or Anti-Corruption and Betting Regulations:
    - (i) the charges will be read; and
    - (ii) the Player or Person will be asked to confirm if he admits that he has committed the act or acts of Misconduct or breaches of the Regulation(s) for which he is charged;
  - (c) for cases involving Ordering Off:
    - (i) the referee's report and, where applicable, the assistant referee's report shall be read;
    - (ii) the Player shall be asked to confirm if he admits that he has committed an act or acts of Foul Play; and
    - (iii) the Player will be given the opportunity to say whether or not he will seek to show that the referee's decision was wrong (and if so why);

- (d) for cases involving a citing the procedures in (c)(ii) and (iii) above shall be applied, subject to such modification as the Judicial Committee or Judicial Officer deems appropriate;
  - (e) evidence from the Player or Person if he elects to give evidence, and from any witnesses to be called will be heard; and
  - (f) final submissions will be heard.
- 3.10 For cases involving citing complaints initiated by a Citing Commissioner, Misconduct or other breaches of the Regulations, the Judicial Committee Chairman or Judicial Officer may request that a person be available to present the case and set out the basis of the citing complaint, Misconduct or other charges.
- 3.11 The Player or Person subject to disciplinary proceedings may admit the offence at any time in which case the Judicial Committee or Judicial Officer should proceed immediately to hear submissions in relation to sanction.
- 3.12 Where disciplinary proceedings, however arising, are taken against more than one Player or Person as a result of incidents occurring in a Match or arising from the same incident or series of incidents, such proceedings may be heard by a Judicial Committee or Judicial Officer at the same time, provided there is no prejudice to any person against whom the disciplinary proceedings are taken.
- 3.13 Upon the finding of a breach of the Bye-Laws and/or Regulations Judicial Committees and Judicial Officers shall be entitled to impose such penalties and orders as they think fit which may include the penalties and orders set out in Regulation 18.6.1.
- 4. Appeal Committees and Appeal Officers – Power to regulate their own procedures**
- 4.1 The Appeal Committee or Appeal Officer are entitled to receive and shall be provided with the full record of the proceedings before the Judicial Committee or Judicial Officer.
- 4.2 An Appeal Committee or Appeal Officer shall have power to conduct and regulate the appeal proceedings as it sees fit having regard to the circumstances of the case but shall generally conform to the procedures stated in this Regulation 18, Appendix 1.
- 4.3 The Appeal Committee or Appeal Officer shall have the power to order that a de novo hearing in whole or in part be adopted on appeal. A de novo hearing in whole or in part would ordinarily only be appropriate where it is established that it is in the interests of justice that a re-hearing of the case in whole or in part is necessary. In the case of an appeal which proceeds in whole as a de novo hearing the procedure to be adopted, the burden of proof and all evidential and other matters shall proceed as if the hearing was a first instance hearing before a Judicial Committee or Judicial Officer.



- 4.4 Except where an appeal proceeds in whole or in part, and then only with respect to that part, as a de novo hearing and subject to clause 3.3 above, appeals and any question of fact arising on appeal will be heard and determined based on the record of the decision and the evidence received and considered by the Judicial Committee or Judicial Officer.
- 4.5 Except where an appeal proceeds in whole as a de novo hearing it is for the Appellant to establish that the decision being challenged on appeal:
- (a) was in error (either as to central factual findings or in law);
  - (b) in the interests of justice should be overturned;
  - (c) the sanction imposed was manifestly excessive or wrong in principle; and/or
  - (d) the sanction imposed was unduly lenient.
- 4.6 Except where an appeal proceeds in whole or in part, and then only with respect to that part, as a de novo hearing, appeals shall be conducted on the basis that:
- (a) the evidential assessment or decision involving an exercise of discretion or judgment of or by a Judicial Committee or Judicial Officer shall not be overturned save in circumstances where the relevant findings made by the Judicial Committee or Judicial Officer are manifestly wrong;
  - (b) the evidential assessment or decision involving an exercise of discretion or judgment of or by a Judicial Committee or Judicial Officer shall not be overturned save in circumstances where the Judicial Committee or Judicial Officer applied wrong principles in the exercise of its/his discretion which has resulted in an erroneous decision being made; and/or
  - (c) new or additional evidence not offered before the Judicial Committee or Judicial Officer shall only be considered by the Appeal Committee or Appeal Officer where the party offering such evidence establishes that it was not, on reasonable enquiry, available at the time of the proceedings before the Judicial Committee or Judicial Officer.
- 4.7 Where the Appellant appeals against the sanction and/or cost order alone, the Appellant may request that the Appeal Committee or Appeal Officer review the sanction without the need for a personal hearing. The Appeal Committee or Appeal Officer may also determine that a personal hearing is not required in relation to any appeal but if it/he so wishes, the Appellant always has the right to appear and make representations in all cases in person or by way of technology or alternatively he may make representations in writing.

- 4.8 The Chairman of the Appeal Committee and the Appeal Officer shall be entitled to determine pre-hearing procedural and/or evidential matters. Such matters may include:
- (a) a pre-hearing conference convened for the purposes of giving directions for the hearing and clarification of the procedures; and/or
  - (b) the requirement for any person to attend the hearing as a witness.
- For the purposes of pre-hearing case management the Chairman of the Appeal Committee may exercise this function without reference to the other Appeal Committee members.
- 4.9 The Appeal Committee or Appeal Officer shall set a time, date and place for the hearing of the appeal which shall be notified by Rugby World, Host Union or Tournament Organiser to the Appellant(s) who has lodged the appeal.
- 4.10 Where a Player is suspended, provisionally suspended or had other sanctions imposed, such suspension and/or sanction shall remain in place pending the outcome of an Appeal.
- 4.11 If a Member of the Appeal Committee or Appeal Officer is unable or unwilling, for whatever reason, to hear the appeal, then World Rugby, Host Union or Tournament Organiser through an independent process may, at its absolute discretion:
- (a) appoint a replacement; or
  - (b) appoint a new Appeal Committee or new Appeal Officer; or
  - (c) allow the remaining members of the Appeal Committee to hear the appeal.
- 4.12 Appeal Committees and Appeal Officers shall:
- (a) have the power to direct that World Rugby, Union or Tournament Organiser be represented. If so, World Rugby, Union or Tournament Organiser shall be represented by a designated disciplinary officer (or his nominee) and may appear by counsel at the hearing of the appeal in such capacity as the Appeal Committee or Appeal Officer requires, to assist it/him in the discharge of its/his duties;
  - (b) may permit such other persons to be present at the hearing of the appeal as they see fit;
  - (c) in any case where a witness has been required to attend and refuses and/or fails to attend the hearing, the Appeal Committee or Appeal Officer may decide whether or not to allow the evidence of that witness to be given in any other form;
  - (d) be entitled to determine whether witnesses that give evidence are entitled to remain within the room in which the appeal is being heard after their evidence has been given; and

- (e) subject to clauses 3.3 to 3.5 be entitled to receive evidence in such form as it thinks fit (including evidence in writing), including evidence which may not be admissible in a court or tribunal and should be entitled to attach such weight to that evidence as it/he sees fit.
- 4.13 Save where the Appeal Committee or Appeal Officer decides to hear the entire case de novo, the Appellant shall have the burden of proving that the decision being challenged should be overturned or varied.
- 4.14 The Appeal Committee or Appeal Officer shall have the powers ascribed to it in Regulation 18.8.1 including the power to deal with penalties and costs as set out in Regulation 18.8.1.
- 4.15 The decision of the Appeal Committee or Appeal Officer shall be advised to the parties as soon as practicable after the conclusion of the hearing and shall be final and binding on notification to the Union, Player and/or Person. Where it considers it appropriate, the Appeal Committee or Appeal Officer may deliver a short oral decision at the conclusion of the hearing (with its/his reasons to be put in writing and communicated to the parties at a later date) or it/he may reserve its decision.
- 4.16 Relevant parties heard by the Appeal Committee or Appeal Officer shall be entitled to a copy of the Appeal Committee's or Appeal Officer's written decision which shall be provided by the Appeal Committee or Appeal Officer as soon as practicable after it is available.



---

### REGULATION 19. MEDIATION

- 19.1** In the event of a dispute between Unions and/or Associations, the Unions and/or Associations concerned may request the CEO to appoint a mediator to assist in settling the differences between the parties.
- 19.2** Only where the CEO and all the parties who are involved in a dispute consent in writing, may a matter be referred to a mediator for consideration in accordance with Clause 19.1 above.



## REGULATION 20. MISCONDUCT AND CODE OF CONDUCT

### Preamble

- A** Adherence to the Laws of the Game, Regulations Relating to the Game and the spirit of fair play remains fundamental to the proper administration and preservation of the Game in the modern era. Accordingly, a general obligation arises on all stakeholders to address Misconduct matters within their jurisdictions to ensure that discipline, control, honesty and mutual respect which are fundamental to the integrity of the Game are preserved.
- B** This Regulation 20 sets out a harmonised approach to the administration of discipline and the implementation of sanctions for Misconduct at all levels of the Game. The administration of this Regulation shall be carried out on behalf of World Rugby by the Disciplinary Officer in consultation with World Rugby.
- C** All participants in the Game by means of their participation recognise and agree to be bound by the principle of universality which means that Players who are suspended at any level of the Game shall have their suspension recognised and applied at all levels of the Game and in the territories of all member Unions and Associations.

### Application of the Regulation

- 20.1** The provisions of this Regulation including the World Rugby Code of Conduct (Appendix 1) apply to all Unions and Associations within their respective jurisdictions at all levels and it is their responsibility to advise their Players, Persons and Rugby Bodies of this Regulation. Unions and Associations shall ensure that they have in place disciplinary regulations compatible and not in conflict with this Regulation 20 and such regulations are applied to and complied with by all Players, Persons and Rugby Bodies within their jurisdiction.
- 20.2** Any act of Misconduct shall constitute an offence under this Regulation and may result in disciplinary proceedings being brought against and sanctions being imposed upon the Player, Person, Union, Association and/or Rugby Body involved.
- 20.3** For the purposes of these Regulations Relating to the Game, “**Misconduct**” shall mean any conduct, behaviour, statements and/or practices on or off the playing enclosure during or in connection with a Match or otherwise, that is unsporting and/or cheating and/or insulting and/or unruly and/or ill-disciplined and/or that brings or has the potential to bring the Game and/or any of its constituent bodies, World Rugby and/or its appointed personnel or commercial partners and/or Match Officials and/or judicial personnel into disrepute. Misconduct shall only exclude Foul Play during a Match which has been the subject of consideration and a finding under the regime prescribed for Ordering Off and/or Citing in Regulation 17.

- 20.4** While it is not possible to provide a definitive and exhaustive list of the types of conduct, behaviour, statements or practices that may amount to Misconduct under these Regulations, by way of illustration, each of the following types of conduct, behaviour, statements or practices however or wheresoever undertaken are examples of and constitute Misconduct:
- (a) acts of violence or intimidation within the venue in which the Match is being played including (without limitation) the tunnel, changing rooms and/or warm-up areas;
  - (b) acting in an abusive, insulting, intimidating or offensive manner towards referees, assistant referees, Citing Commissioners, members of Disciplinary Tribunals or other officials or any person associated with the Host Union, the Rugby Body or the Unions participating in the Match or spectators;
  - (c) acts or statements that are, or conduct that is, discriminatory by reason of religion, race, sex, sexual orientation, disability, colour or national or ethnic origin;
  - (d) any breach of Regulation 6 (Wagering);
  - (e) providing inaccurate and/or misleading information about the previous disciplinary record of the Player or Person in any proceedings under this Regulation or Regulations 17 or 21 or other disciplinary proceedings and/or misleading information concerning the Player's future playing intentions;
  - (f) any breach of Regulation 20 Appendix 1 (Code of Conduct);
  - (g) comments and/or conduct in connection with current and/or anticipated disciplinary proceedings and/or Match officiating (or any aspect thereof), which may be prejudicial to or adversely impact such proceedings and/or which are prejudicial to the interests of the Game and/or any Person and/or any disciplinary personnel (including Disciplinary Tribunals and Citing Commissioners);
  - (h) failure to cooperate with the citing and/or judicial process in the absence of a reasonable explanation or making a citing referral frivolously or in bad faith;
  - (i) failure or refusal by a Player, Person or Union to cooperate fully with any investigations conducted pursuant to the wagering rules (Regulation 6), or the anti-doping rules (Regulation 21), or in connection with any complaint or dispute which is or could be brought before a Disciplinary or Appeal Committee or Judicial or Appeal Officer; and/or
  - (j) making any comments (including to the media) that attack, disparage or denigrate the Game and/or any of its constituent bodies, World Rugby and/or its appointed personnel or commercial partners and/or Match Officials and/or disciplinary personnel (including Disciplinary Tribunals and Citing Commissioners).



- 20.5** Unions are responsible and accountable for the conduct of their Players and all Persons within their jurisdiction. Unions, Players and Persons must conduct themselves in a disciplined and sporting manner and ensure that they do not commit any act(s) of Misconduct.
- 20.6 The Role of the Host Union, Association or duly recognised Tournament Organiser in Misconduct Matters**
- 20.6.1 The Host Union shall nominate a designated disciplinary officer who shall administer this Regulation and shall be entitled to undertake such investigations (personally or through a nominee(s)) as he may consider necessary into incidents that constitute or may be capable of constituting Misconduct on the part of Players and/or Persons and/or Rugby Bodies within their jurisdiction in accordance with Regulation 20.
- 20.6.2 In the context of a Match or tournament, the role of the designated disciplinary official may be delegated to the Citing Commissioner or the Citing Commissioner Liaison Officer, the Match commissioner or other suitable person.
- 20.6.3 For Matches forming part of the merit based appointment scheme that are not World Rugby Matches, in the event that a designated disciplinary officer is not appointed or the appointee is unable to fulfil the role or in the opinion of the Disciplinary Officer cannot independently exercise such role, then in such circumstances the Disciplinary Officer on behalf of World Rugby may appoint the designated disciplinary officer including himself.
- 20.6.4 Where a Misconduct investigation is into the activities of a Union, Association or Tournament Organiser and/or its appointed personnel, the designated disciplinary officer shall be independent of the Union, Association and/or Tournament Organiser. If in the reasonable opinion of the Disciplinary Officer, the Union, Association or Tournament Organiser is unable to independently exercise such role, then the Disciplinary Officer may on behalf of World Rugby appoint the designated disciplinary officer including himself.
- 20.6.5 Nothing in this Regulation shall limit or restrict the right of the Disciplinary Officer on behalf of World Rugby to appoint a designated disciplinary officer to undertake such investigations as he may consider necessary into incidents that constitute or may be capable of constituting Misconduct or acts which have the potential to bring the Game or World Rugby into disrepute on the part of Players, Persons, Unions, Associations and/or Rugby Bodies. This provision shall apply equally to situations where no action or insufficient action has been taken by the Union, Association or Tournament Organiser.
- 20.6.6 No person who is a member or a paid employee of a Union or other affiliated organisation responsible for the management of either team participating in a Match shall be eligible for appointment as a designated disciplinary official.

## 20.7 Initial Procedures – Misconduct

- 20.7.1 The designated disciplinary official (or his nominee) shall be entitled to undertake such investigations as he may consider necessary into incidents that constitute or may be capable of constituting Misconduct involving any Player, Person and/or Rugby Body within his jurisdiction. Every Union, Association, Rugby Body, Player and Person shall be obliged to cooperate with any such investigations, referrals and/or hearings and a failure to cooperate with such investigation may itself constitute Misconduct under this Regulation.
- 20.7.2 Subject to the provisions of this Regulation 20, the designated disciplinary official shall determine whether to investigate an incident or incidents and/or to bring a Misconduct complaint against any Player, Person and/or a Rugby Body within his jurisdiction and his decision in respect of both initiating an investigation and/or bringing a Misconduct complaint shall be final.
- 20.7.3 Notwithstanding Regulation 20.7.1 where the designated disciplinary officer has reason to believe that an act or acts of Misconduct may have been committed by a Union or Association, he must immediately inform the Disciplinary Officer of World Rugby, in writing. The Disciplinary Officer or his nominee shall then deal with the matter as he considers appropriate.
- 20.7.4 In cases involving conduct and/or behaviour that in the opinion of the designated disciplinary officer of a Host Union are more appropriately dealt with by a visiting Union, or World Rugby, the designated disciplinary officer may, on behalf of the Host Union, refer the matter to the visiting Union or World Rugby to deal with.
- 20.7.5 In cases involving conduct and/or behaviour that in the opinion of the designated disciplinary officer of the Tournament Organiser are more appropriately dealt with by the Union of the Player or Person concerned or World Rugby, the designated disciplinary officer may, on behalf of the Tournament Organiser refer the matter to the Union of the Player or Person concerned or World Rugby to deal with.
- 20.7.6 Where any referral is made to World Rugby, World Rugby shall determine if it is appropriate in all the circumstances to take over the matter. Where World Rugby agrees to take up the matter, the relevant Union or Tournament Organiser shall assist World Rugby with the case (and/or investigation) and shall be responsible for payment of any unrecovered costs arising from the referral.
- 20.7.7 If a matter is referred to a visiting Union, pursuant to Regulation 20.7.4 above, or is referred to the Union of the Player or Person concerned, pursuant to Regulation 20.7.5 then the visiting Union or Union of the Player or Person concerned shall be obliged to progress the matter in accordance with disciplinary procedures which shall be based on those set out in this Regulation and shall advise the Disciplinary Officer of World

Rugby who shall have the right to require that the referring Union or Tournament Organiser or World Rugby retain conduct of the matter.

- 20.7.8 If the Disciplinary Officer (or his nominee) allows the visiting Union or the Union of the Player or Person to whom the matter has been referred pursuant to Regulation 20.7.4 or 20.7.5 to handle the case then they shall report the outcome to the Disciplinary Officer of World Rugby as soon as it is concluded.
- 20.7.9 The Disciplinary Officer (or his nominee) may take such action against the Union, Association, Player, Person and/or Rugby Body concerned as he considers appropriate in the event that the visiting Union or Union of the Player or Person concerned do not conclude the investigation and/or adjudicate on the matter expeditiously and in good faith.
- 20.7.10 If the designated disciplinary officer elects to bring a Misconduct complaint, then the matter shall be referred to an independent Judicial Committee or Judicial Officer for consideration.

### **20.8 Misconduct Complaint**

- 20.8.1 Subject to Regulations 20.6.1 and 20.7.2 any Misconduct complaint by the designated disciplinary officer shall be sent in writing to the Union of the Player, Person or body against whom the Misconduct complaint is made (or other applicable body). The Misconduct complaint should contain the following information:
- (a) date and place of the alleged Misconduct;
  - (b) the name of the Player, Person or other party in respect of whom the complaint is made and (where applicable) his/their Rugby Body or Union; and
  - (c) details of the alleged Misconduct (including brief details of the evidence to be relied upon).
- 20.8.2 On receipt of a Misconduct complaint, the Union shall send a copy of the Misconduct complaint and applicable information and/or reports to the Player or Person (and their Rugby Body) or other party in respect of whom it is made together with notification of the appointed Judicial Committee or Judicial Officer and relevant details regarding the Misconduct hearing.
- 20.8.3 A Union, Tournament Organiser, Player or Person may refer an allegation of Misconduct to the designated disciplinary officer appointed by the Host Union or Tournament Organiser having jurisdiction. The designated disciplinary officer shall consider the matter and determine whether to bring a Misconduct complaint or not as a result of a referral subject always to the provisions of this Regulation.

## **20.9 Judicial Committee or Judicial Officer – Power to regulate its/his Own Procedures**

- 20.9.1 The general procedures relating to hearings before Judicial Committees and Judicial Officers contained in Regulation 18, Appendix 1 shall apply to any matter arising under this Regulation. In this regard disciplinary proceedings shall include for the avoidance of doubt Misconduct proceedings.
- 20.9.2 The Judicial Committee or Judicial Officer shall deal with cases involving alleged Misconduct as soon as practicable and at a convenient location for the Union, Player or Person subject to the Misconduct proceedings. This location does not have to be in the country in which the alleged Misconduct took place and shall be determined by the Judicial Committee or Judicial Officer in consultation with the Host Union or Tournament Organiser or World Rugby (as appropriate).
- 20.9.3 The Judicial Committee or Judicial Officer may at its or his discretion impose a provisional suspension on a Player or Person subject to a Misconduct complaint pending the resolution of the case.
- 20.9.4 At any hearing of a Misconduct complaint, the designated disciplinary officer (or his nominee) shall be in attendance to explain the basis of the Misconduct complaint and present the Misconduct complaint and he may be assisted by a legal advisor.
- 20.9.5 The designated disciplinary officer shall have the burden of proving, on the balance of probabilities, that an act or acts of Misconduct have been committed. The Player, Person or other party subject to the Misconduct complaint shall be asked if he accepts that he has committed an act of Misconduct. The Judicial Committee or Judicial Officer shall determine its/his factual findings and whether it/he is satisfied on the balance of probabilities that an act or acts of Misconduct has been committed by the Player, Person or other party concerned.

## **20.10 Sanctions for Misconduct**

- 20.10.1 If a Judicial Committee or Judicial Officer determines that an act or acts of Misconduct have been committed then it/he shall receive and consider representations on sanctions. The Judicial Committees and Judicial Officers shall be entitled to impose such sanction as they think fit on the Union, Person and/or Player and/or other party concerned including, but not limited to, the following:
- (a) a caution, warning as to future conduct, reprimand;
  - (b) a fine and/or compensation orders;
  - (c) a suspension for a specified number of Matches (including all on-field activities) or period of time;
  - (d) expulsion from the remainder of a Tournament and/or Series of Matches;

- (e) exclusion orders from Unions or grounds within Unions;
- (f) suspension from involvement in officiating, coaching and/or administration of the Game;
- (g) the withdrawal of other benefits of membership of World Rugby including but not limited to the right to apply to host World Rugby Matches or International Tournaments and/or funding;
- (h) the deduction or cancellation of points or any such similar sports or tournament based sanction; and/or
- (i) any combination of the above or such other sanction as may be appropriate.

And in the case of Sevens Matches and/or Sevens Tournaments the following additional sanctions may be imposed:

- (j) the cancellation of a Match result;
- (k) the replaying of a Match;
- (l) the forfeiture of a Match;
- (m) the deduction or cancellation of points or any such similar sports or tournament based sanction; and/or
- (n) any combination of the above or such other sanction as may be appropriate.

When imposing a sanction for Misconduct the Judicial Committee or Judicial Officer shall describe the precise nature of any suspension and its scope and the extent of any activities restricted and/or prohibited.

- 20.10.2 The decision of the Judicial Committee or Judicial Officer shall be communicated to the relevant Union, Player, Person or other party concerned and/or their representatives as soon as reasonably practicable and shall be binding upon notification to the Union, Player and/or Person concerned or their representatives. In cases handled by a Union, Association or Tournament Organiser involving an International Match or Match forming part of an International Tour, World Rugby shall also be notified immediately. All decisions in Misconduct cases shall be made available to World Rugby upon request.
- 20.10.3 Any penalties imposed shall remain effective pending the final determination of the appeal.
- 20.10.4 Any decision of World Rugby and/or a decision of a Union, Association or Tournament Organiser where such decision is recognised and accepted by World Rugby shall be recognised and applied (including any sanctions thereunder) by all Unions, Associations and Rugby Bodies who shall take all necessary actions to render such decision effective within their jurisdiction(s).

## 20.11 Appeals In Relation To Misconduct Matters

- 20.11.1 A Player, Person or other party who is found to have committed an act or acts of Misconduct shall have the right to appeal against the finding of an offence of Misconduct and/or the sanction imposed. In cases handled by a Union or Tournament Organiser, the Union, Tournament Organiser and World Rugby shall have the right to appeal.
- 20.11.2 The following parties (Appellants) shall be entitled to appeal to an Appeal Committee or Appeal Officer from the decision of a Judicial Committee or Judicial Officer:
- (a) the Player, Person or other party the subject of the Misconduct decision;
  - (b) the Host Union; or
  - (c) the Tournament Organiser; and
  - (d) World Rugby in respect of all World Rugby Matches and Matches falling under the merit based appointment scheme.
- 20.11.3 To be valid, any appeal against the decision of a Judicial Committee or Judicial Officer in relation to Misconduct must be lodged with the designated disciplinary officer (or his nominee) in writing within **7 days** of the notification of the decision to the Player, Person or other party concerned, or his/their representative(s), if any. For the purposes of Regulation 20 “decision” shall mean the final written decision of the Judicial Committee or Judicial Officer.
- 20.11.4 If the Host Union or Tournament Organiser shall so require, each notice of appeal shall be accompanied by a deposit of an amount not exceeding the equivalent of £1,000 (pounds sterling), such amount to be determined by the Host Union or Tournament Organiser. In the event of a required deposit not being paid, the appeal shall be deemed to be abandoned, save that the Appeal Committee or Appeal Officer, in any case, shall have power to extend the time for payment of the deposit. In the event of an appeal by World Rugby, the Host Union or Tournament Organiser no appeal deposit shall be payable.
- 20.11.5 World Rugby has a supervisory jurisdiction in respect of disciplinary matters (Misconduct). In the event the Disciplinary Officer determines it is appropriate that a particular decision should be appealed the Disciplinary Officer on behalf of World Rugby shall have the right to appeal the matter, and such right of appeal shall be exercised within **7 days** following receipt of the decision.
- 20.11.6 The appeal shall be heard as soon as reasonably practicable. The appeal shall be dealt with in the most convenient location having regard to the Player(s), Person(s) or other party(ies) involved. It need not take place in the country in which the Misconduct occurred. This will be determined by the appointed Appeal Committee Chairman or Appeal Officer in

consultation with the Host Union or Tournament Organiser or World Rugby (as appropriate).

- 20.11.7 The Appeal Committee or Appeal Officer shall determine the basis on which the appeal shall proceed, including the standard of review. The general procedures relating to hearings before Appeal Committees and Appeal Officers contained in Regulation 18, Appendix 1 shall apply to any matter arising under this Regulation.
- 20.11.8 In the event of an appeal against the decision of a Judicial Committee or Judicial Officer with respect to Misconduct, the sanction, if any, imposed by the Judicial Committee or Judicial Officer shall apply until the case has been dealt with by an Appeal Committee or Appeal Officer.
- 20.11.9 The majority decision of the Appeal Committee or the decision of the Appeal Officer (as the case may be) shall be effective immediately on notification to the Appellant and/or his representatives and shall be final and binding.
- 20.11.10 For cases handled by a Union or Tournament Organiser the Union or Tournament Organiser shall submit to the Disciplinary Officer of World Rugby the decision and where requested a full report of proceedings and conclusions in Misconduct matters arising out of or within its jurisdiction within **14 days** of the final decision having been made. The Disciplinary Officer, or his nominee, may, on behalf of World Rugby, accept the result or refer the matter to the appropriate body for consideration.

### **20.12 Additional Provisions**

- 20.12.1 Judicial Committees, Judicial Officers, Appeal Committees and Appeal Officers, prior to a hearing or at any stage during a hearing may amend the offence for which the Player, Person or other party has been charged unless, having regard to the circumstances of the case, such amendment cannot be made without causing injustice. Where an amendment is made, in appropriate cases an adjournment may be granted.
- 20.12.2 Where Misconduct proceedings, however arising, are taken against more than one Player, Person or other party as a result of incidents occurring in or in connection with a Match or tournament, such proceedings may be heard by a Judicial Committee or Judicial Officer at the same time, provided there is no prejudice to any Player, Person or other party against whom the Misconduct proceedings are taken.

### **20.13 Exceptional Circumstances in relation to Players' Conduct**

- 20.13.1 In exceptional circumstances where the conduct of a Player(s) or Person(s) is of such a serious/gross nature that his or their continued involvement in the Game in any capacity pending the final determination of the matter by the relevant authority is deemed by World Rugby to be inappropriate and/or potentially prejudicial to the image and reputation of the sport, then World Rugby is entitled to require as it deems fit that the relevant Union(s) provisionally suspend such Player(s) or Person(s) from any involvement in the sport.

20.13.2 It is the responsibility of each Union in membership of World Rugby to ensure that in such circumstances it is able by reference to its regulations or otherwise to effect and/or recognise such provisional suspension on the Player or Person concerned.

#### **20.14 Unforeseen Circumstances**

20.14.1 In respect of any matter not provided for in this Regulation the appropriate body or Person shall take a decision according to general principles of natural justice and fairness.

#### **20.15 The Role of World Rugby in Misconduct Matters**

20.15.1 Where World Rugby reasonably determines that circumstances exist or could arise where it is in the overall interests of the Game to intercede, World Rugby shall be entitled to appoint a designated disciplinary officer to undertake an investigation into incidents that constitute or may be capable of constituting Misconduct on the part of a Player, Person or other party.

20.15.2 World Rugby shall appoint a designated disciplinary officer for all World Rugby Matches.

20.15.3 Where World Rugby appoints a designated disciplinary officer, the role shall be undertaken by the Disciplinary Officer of World Rugby (or his nominee).

#### **20.16 Special Provisions relating to Sevens Matches and Tournaments**

20.16.1 The structure of Sevens events, with multiple Matches taking place on the same day, means that expedition in dealing with any Misconduct matters which may arise is important. The supplemental provisions in this Regulation 20.16 are intended to provide assistance in dealing expeditiously with Misconduct complaints at Sevens events.

20.16.2 Ordinarily a Judicial Officer shall be appointed to deal with Misconduct matters at Sevens events.

20.16.3 The Judicial Officer shall deal with cases involving alleged Misconduct as soon as practicable and, wherever possible, during the course of the tournament. If a case is not dealt with during the course of a tournament it will, ordinarily, be dealt with as soon as reasonably practicable following the conclusion of the tournament, at a convenient location for the Player(s), Person(s) or other party(ies) concerned. This location does not have to be in the country in which the tournament was played and shall be determined by the Judicial Officer in consultation with the Host Union or Tournament Organiser or World Rugby.

20.16.4 To be valid, any appeal against the decision of a Judicial Officer in relation to Misconduct must be lodged with the designated disciplinary officer (or his nominee) in writing within **7 days** of the notification of the written decision of the Judicial Officer to the Union, or Player or Person concerned, or his/their representative(s), if any.



- 20.16.5 If a Player, Person or other party named in Regulation 20.11 lodges an appeal pursuant to Regulation 17.22.4 then, subject to the discretion of the Appeal Committee Chairman or Appeal Officer (as appropriate) and, where reasonably practicable, the appeal shall be dealt with during the course of the tournament. If the appeal is not dealt with during the course of the tournament, it will be dealt with as soon as reasonably practicable thereafter and, ordinarily, within **7 days** of the lodgement of the appeal.

## APPENDIX 1. CODE OF CONDUCT

1. All Unions, Associations, Rugby Bodies, Clubs and Persons:
  - 1.1 must ensure that the Game is played and conducted in accordance with disciplined and sporting behaviour and acknowledge that it is not sufficient to rely solely upon the Match Officials to maintain those principles;
  - 1.2 shall co-operate in ensuring that the spirit of the Laws of the Game are upheld and refrain from selecting players guilty of foul play;
  - 1.3 shall not repeatedly breach the Laws of the Game;
  - 1.4 shall accept and observe the authority and decisions of referees, touch judges, Match Officials and all other rugby disciplinary bodies, subject to Regulation 17;
  - 1.5 shall not publish or cause to be published criticism of the manner in which a referee or touch judge handled a Match;
  - 1.6 shall not publish or cause to be published criticism of the manner in which Council or any other rugby disciplinary body handled or resolved any dispute or disciplinary matter resulting from a breach of the Bye-Laws, Regulations, or Laws of the Game;
  - 1.7 shall not engage in any conduct or any activity on or off the field that may impair public confidence in the honest and orderly conduct of a Match, tour, tournament or Series of Matches (including, but not limited to, the supply of information in relation to the Game, directly or indirectly, to bookmakers or to persons who may use such information to their advantage) or in the integrity and good character of any Person;
  - 1.8 shall not commit a breach of Regulation 6 (Wagering);
  - 1.9 shall promote the reputation of the Game and take all possible steps to prevent it from being brought into disrepute;
  - 1.10 shall not commit an anti-doping rule violation as defined in Regulation 21;
  - 1.11 shall not abuse, threaten or intimidate a referee, touch judge or other Match Official, whether on or off the field of play;
  - 1.12 shall not use crude or abusive language or gestures towards referees, touch judges or other Match Officials or spectators;
  - 1.13 shall not do anything which is likely to intimidate, offend, insult, humiliate or discriminate against any other Person on the ground of their religion, race, sex, sexual orientation, colour or national or ethnic origin;
  - 1.14 shall not do anything which adversely affects the Game of Rugby Football, World Rugby, any member Union or Association or any commercial partner of the Game.

- 
2. Each Union and Association is under an obligation to comply with and to ensure that each of its members comply with this Code of Conduct and adopt procedures to monitor compliance with and impose sanctions for breaches of the Code of Conduct by Persons under its jurisdiction.



## **REGULATION 21. ANTI-DOPING**

### **INTRODUCTION AND PRINCIPLES**

- (i) PREFACE
  - (ii) FUNDAMENTAL RATIONALE FOR THE CODE AND THE WORLD RUGBY ANTI-DOPING RULES
  - (iii) SCOPE OF THESE ANTI-DOPING RULES
- 21.1 DEFINITION OF DOPING**
  - 21.2 ANTI-DOPING RULE VIOLATIONS**
  - 21.3 PROOF OF DOPING**
  - 21.4 THE PROHIBITED LIST**
  - 21.5 TESTING AND INVESTIGATIONS**
  - 21.6 ANALYSIS OF SAMPLES**
  - 21.7 RESULTS MANAGEMENT**
  - 21.8 RIGHT TO A FAIR HEARING**
  - 21.9 AUTOMATIC DISQUALIFICATION OF INDIVIDUAL RESULTS**
  - 21.10 SANCTIONS ON INDIVIDUALS**
  - 21.11 CONSEQUENCES TO TEAMS**
  - 21.12 SANCTIONS AND COSTS ASSESSED AGAINST SPORTING BODIES**
  - 21.13 APPEALS AND POST-HEARING REVIEWS**
  - 21.14 CONFIDENTIALITY AND REPORTING**
  - 21.15 APPLICATION AND RECOGNITION OF DECISIONS**
  - 21.16 INCORPORATION OF WORLD RUGBY ANTI-DOPING RULES AND OBLIGATIONS OF MEMBER UNIONS**
  - 21.17 STATUTE OF LIMITATIONS**
  - 21.18 WORLD RUGBY COMPLIANCE REPORTS TO WADA**
  - 21.19 EDUCATION**
  - 21.20 AMENDMENT AND INTERPRETATION OF ANTI-DOPING RULES**

<b>21.21</b>	<b>INTERPRETATION OF THE CODE</b>
<b>21.22</b>	<b>ADDITIONAL ROLES AND RESPONSIBILITIES OF PLAYERS AND OTHER PERSONS</b>
<b>21.23</b>	<b>ADDITIONAL ROLES AND RESPONSIBILITIES OF UNIONS</b>
<b>21.24</b>	<b>WORLD RUGBY ANTI-DOPING ADVISORY COMMITTEE</b>
<b>21.25</b>	<b>EXCEPTIONAL CIRCUMSTANCES</b>
<b>21.26</b>	<b>UNFORSEEN CIRCUMSTANCES</b>
<b>21.27</b>	<b>GENERAL</b>
<b>APPENDIX 1</b>	<b>DEFINITIONS</b>
<b>APPENDIX 2</b>	<b>COMMENTS</b>
<b>SCHEDULE 1</b>	<b>Doping Control Procedural Guidelines</b>
<b>SCHEDULE 2</b>	<b>WADA Prohibited List</b>
<b>SCHEDULE 3(a)</b>	<b>WADA International Standard for Therapeutic Use Exemptions (TUE)</b>
<b>SCHEDULE 3(b)</b>	<b>World Rugby TUE Application Form</b>
<b>SCHEDULE 4</b>	<b>Acknowledgements and Agreement Form</b>
<b>SCHEDULE 5</b>	<b>Player Information Notice–Data Privacy</b>

## WORLD RUGBY ANTI-DOPING RULES

### INTRODUCTION AND PRINCIPLES

#### i. Preface

These Anti-Doping Rules are adopted and implemented in accordance with World Rugby's responsibilities under the Code, and in furtherance of World Rugby's continuing efforts to eradicate doping in sport.

These Anti-Doping Rules are sport rules governing the conditions under which sport is played. Aimed at enforcing anti-doping principles in a global and harmonised manner, they are distinct in nature from criminal and civil laws, and are not intended to be subject to or limited by any national requirements and legal standards applicable to criminal or civil proceedings. When reviewing the facts and the law of a given case, all courts, arbitral tribunals and other adjudicating bodies should be aware of and respect the distinct nature of these Anti-Doping Rules implementing the Code and the fact that these rules represent the consensus of a broad spectrum of stakeholders around the world as to what is necessary to protect and ensure fair sport.

#### ii. Fundamental Rationale for the Code and World Rugby Anti-Doping Rules

Anti-doping programmes seek to preserve what is intrinsically valuable about sport. This intrinsic value is often referred to as "the spirit of sport". It is the essence of Olympism, the values of Rugby, the pursuit of human excellence through the dedicated perfection of each person's natural talents. It is how we play true and Keep Rugby Clean. The spirit of sport is the celebration of the human spirit, body and mind, and is reflected in Rugby's values:

- Integrity
- Respect
- Solidarity
- Passion
- Discipline

Doping is fundamentally contrary to the spirit of sport and the values of Rugby.

World Rugby adopted the World Anti-Doping Code ("Code") in June 2004. Following an international review of the Code by all Signatories a new World Anti-Doping Code 2015 has been agreed with an effective implementation date of 1 January 2015.

All provisions of the Code are mandatory in substance. The mandatory provisions and principles of the Code have been adopted and incorporated into the revised World Rugby Regulation 21.

#### iii. Scope of these Anti-Doping Rules

These Anti-Doping Rules shall apply to World Rugby and to all Member Unions and Associations. They also apply to the following: Players, Player Support Personnel and other Persons, each of whom is deemed, as a condition of his membership, accreditation and/or participation in the Game in any capacity, to have agreed to be bound by these Anti-Doping Rules, and to have submitted to the authority of World Rugby to enforce these Anti-Doping Rules and to the jurisdiction of the hearing panels

specified in Regulations 21.8 and 21.13 to hear and determine cases and appeals brought under these Anti-Doping Rules:

- a. all Players and Player Support Personnel who are members of any Member Union or Association, or of any member or affiliate organisation of any Member Union (including any Clubs, Teams, local unions, associations or leagues) including without limitation all National-Level Players and International-Level Players;
- b. all Players and Player Support Personnel participating in such capacity in Events, Competitions and other activities organised, convened, authorised or recognised by World Rugby, or any Member Union or Association, or any member or affiliate organisation of any Member Union or Association (including any Clubs, Teams, local unions, associations or leagues), wherever held; and
- c. any other Player or Player Support Personnel or other Person who, by virtue of an accreditation, registration or other contractual arrangement, or otherwise, is subject to the jurisdiction of World Rugby, or of any Member Union or Association, or of any member or affiliate organisation of any Member Union or Association (including any Clubs, Teams, local unions, associations or leagues), for purposes of anti-doping.

Within the overall pool of Players set out above who are bound by and required to comply with these Anti-Doping Rules, the following Players shall be considered to be International-Level Players for purposes of these Anti-Doping Rules, and therefore the specific provisions in these Anti-Doping Rules applicable to International-Level Players (as regards Testing but also as regards TUEs, whereabouts information, results management, and appeals) shall apply to such Players: International-Level Players are those Players designated by World Rugby as being within its Registered Testing Pool and/or Testing Pools and/or otherwise who is participating in a World Rugby Event(s) and/or Competition(s).



## 21.1 DEFINITION OF DOPING

Doping is defined as the occurrence of one or more of the anti-doping rule violations set forth in Regulation 21.2.1 through Regulation 21.2.10 of these Anti-Doping Rules.

## 21.2 ANTI-DOPING RULE VIOLATIONS

The purpose of Regulation 21.2 is to specify the circumstances and conduct which constitute anti-doping rule violations. Hearings in doping cases will proceed based on the assertion that one or more of these specific rules have been violated.

Players or other Persons shall be responsible for knowing what constitutes an anti-doping rule violation and the substances and methods which have been included on the Prohibited List.

The following constitute anti-doping rule violations:

### 21.2.1 Presence of a Prohibited Substance or its Metabolites or Markers in a Player's Sample

**21.2.1.1** It is each Player's personal duty to ensure that no Prohibited Substance enters his or her body. Players are responsible for any Prohibited Substance or its Metabolites or Markers found to be present in their Samples. Accordingly, it is not necessary that intent, Fault, negligence or knowing Use on the Player's part be demonstrated in order to establish an anti-doping rule violation under Regulation 21.2.1 (Presence). [See [Comment 1](#)]

**21.2.1.2** Sufficient proof of an anti-doping rule violation under Regulation 21.2.1 is established by any of the following: presence of a Prohibited Substance or its Metabolites or Markers in the Player's A Sample where the Player waives analysis of the B Sample and the B Sample is not analysed; or, where the Player's B Sample is analysed and the analysis of the Player's B Sample confirms the presence of the Prohibited Substance or its Metabolites or Markers found in the Player's A Sample; or, where the Player's B Sample is split into two bottles and the analysis of the second bottle confirms the presence of the Prohibited Substance or its Metabolites or Markers found in the first bottle. [See [Comment 2](#)]

**21.2.1.3** Excepting those substances for which a quantitative threshold is specifically identified in the Prohibited List, the presence of any quantity of a Prohibited Substance or its Metabolites or Markers in a Player's Sample shall constitute an anti-doping rule violation.

**21.2.1.4** As an exception to the general rule of Regulation 21.2.1 (Presence), the Prohibited List or International Standards may establish special criteria for the evaluation of Prohibited Substances that can also be produced endogenously.

**21.2.2 Use or Attempted Use by a Player of a Prohibited Substance or a Prohibited Method [See [Comment 3](#)]**

**21.2.2.1** It is each Player's personal duty to ensure that no Prohibited Substance enters his or her body and that no Prohibited Method is Used. Accordingly, it is not necessary that intent, Fault, negligence or knowing Use on the Player's part be demonstrated in order to establish an anti-doping rule violation for Use of a Prohibited Substance or a Prohibited Method.

**21.2.2.2** The success or failure of the Use or Attempted Use of a Prohibited Substance or Prohibited Method is not material. It is sufficient that the Prohibited Substance or Prohibited Method was Used or Attempted to be Used for an anti-doping rule violation to be committed. [See [Comment 4](#)]

**21.2.3 Evading, Refusing or Failing to Submit to Sample Collection**

Evading Sample collection, or without compelling justification refusing or failing to submit to Sample collection after notification as authorized in these Anti-Doping Rules or other applicable anti-doping rules. [See [Comment 5](#)]

**21.2.4 Whereabouts Failures**

Any combination of three missed tests and/or filing failures, as defined in the International Standard for Testing and Investigations, within a twelve-month period by a Player in a Registered Testing Pool.

**21.2.5 Tampering or Attempted Tampering with any part of Doping Control**

Conduct which subverts the Doping Control process but which would not otherwise be included in the definition of Prohibited Methods. Tampering shall include, without limitation, intentionally interfering or attempting to interfere with a Doping Control official, providing fraudulent information to an Anti-Doping Organisation, or intimidating or attempting to intimidate a potential witness. [See [Comment 6](#)]

**21.2.6 Possession of a Prohibited Substance or a Prohibited Method**

**21.2.6.1** Possession by a Player In-Competition of any Prohibited Substance or any Prohibited Method, or Possession by a Player Out-of-Competition of any Prohibited Substance or any Prohibited Method which is prohibited Out-of-Competition unless the Player establishes that the Possession is consistent with a therapeutic use exemption ("TUE") granted in accordance with Regulation 21.4.4 or other acceptable justification.

**21.2.6.2** Possession by a Player Support Person In-Competition of any Prohibited Substance or any Prohibited Method, or Possession by a Player Support Person Out-of-Competition of any Prohibited Substance or any Prohibited Method which is prohibited Out-of-Competition in connection with a Player, Competition or training, unless the Player Support Person establishes that the Possession is consistent with a TUE granted to a Player in accordance with Regulation 21.4.4 or other acceptable justification.

[See [Comment 7](#) and [Comment 8](#)]

**21.2.7 Trafficking or Attempted Trafficking in any Prohibited Substance or Prohibited Method****21.2.8 Administration or Attempted Administration to any Player In-Competition of any Prohibited Substance or Prohibited Method, or Administration or Attempted Administration to any Player Out-of-Competition of any Prohibited Substance or any Prohibited Method that is prohibited Out-of-Competition****21.2.9 Complicity**

Assisting, encouraging, aiding, abetting, conspiring, covering up or any other type of intentional complicity involving an anti-doping rule violation, Attempted anti-doping rule violation or violation of Regulation 21.10.12.1 by another Person.

**21.2.10 Prohibited Association**

Association by a Player or other Person subject to the authority of an Anti-Doping Organisation in a professional or sport-related capacity with any Player Support Person who:

**21.2.10.1** If subject to the authority of an Anti-Doping Organisation, is serving a period of Ineligibility; or

**21.2.10.2** If not subject to the authority of an Anti-Doping Organisation and where Ineligibility has not been addressed in a results management process pursuant to the Code, has been convicted or found in a criminal, disciplinary or professional proceeding to have engaged in conduct which would have constituted a violation of anti-doping rules if Code-compliant rules had been applicable to such Person. The disqualifying status of such Person shall be in force for the longer of six years from the criminal, professional or disciplinary decision or the duration of the criminal, disciplinary or professional sanction imposed; or

**21.2.10.3** Is serving as a front or intermediary for an individual described in Regulation 21.2.10.1 or 21.2.10.2.

In order for this provision to apply, it is necessary that the Player or other Person has previously been advised in writing by an Anti-Doping Organisation with jurisdiction over the Player or other Person, or by WADA, of the Player Support Person's disqualifying status and the potential Consequence of prohibited association and that the Player or other Person can reasonably avoid the association. The Anti-Doping Organisation shall also use reasonable efforts to advise the Player Support Person who is the subject of the notice to the Player or other Person that the Player Support Person may, within 15 days, come forward to the Anti-Doping Organisation to explain that the criteria described in Regulation 21.2.10.1 and 21.2.10.2 do not apply to him or her. (Notwithstanding Regulation 21.17, this Regulation applies even when the Player Support Person's disqualifying conduct occurred prior to the effective date provided in Regulation 21.20.7.)

The burden shall be on the Player or other Person to establish that any association with Player Support Personnel described in Regulation 21.2.10.1 or 21.2.10.2 is not in a professional or sport-related capacity.

Anti-Doping Organisations that are aware of Player Support Personnel who meet the criteria described in Regulation 21.2.10.1, 21.2.10.2, or 21.2.10.3 shall submit that information to WADA. [See [Comment 9](#)]

## **21.3 PROOF OF DOPING**

### **21.3.1 Burdens and Standards of Proof**

World Rugby shall have the burden of establishing that an anti-doping rule violation has occurred. The standard of proof shall be whether World Rugby has established an anti-doping rule violation to the comfortable satisfaction of the hearing panel bearing in mind the seriousness of the allegation which is made. This standard of proof in all cases is greater than a mere balance of probability but less than proof beyond a reasonable doubt. Where these Anti-Doping Rules place the burden of proof upon the Player or other Person alleged to have committed an anti-doping rule violation to rebut a presumption or establish specified facts or circumstances, the standard of proof shall be by a balance of probability. [See [Comment 10](#)]

### **21.3.2 Methods of Establishing Facts and Presumptions**

Facts related to anti-doping rule violations may be established by any reliable means, including admissions. The following rules of proof shall be applicable in doping cases: [See [Comment 11](#)]

**21.3.2.1** Analytical methods or decision limits approved by WADA after consultation within the relevant scientific community and which have been the subject of peer review are presumed to be scientifically valid. Any Player or other Person seeking to rebut this presumption of scientific validity shall, as a condition precedent to any such challenge, first notify WADA of the challenge and the basis of the challenge. CAS on its own initiative may also inform WADA of any such challenge. At WADA's request, the CAS panel shall appoint an appropriate scientific expert to assist the panel in its evaluation of the challenge. Within 10 days of WADA's receipt of such notice, and WADA's receipt of the CAS file, WADA shall also have the right to intervene as a party, appear amicus curiae, or otherwise provide evidence in such proceeding.

**21.3.2.2** WADA-accredited laboratories, and other laboratories approved by WADA, are presumed to have conducted Sample analysis and custodial procedures in accordance with the International Standard for Laboratories. The Player or other Person may rebut this presumption by establishing that a departure from the International Standard for Laboratories occurred which could reasonably have caused the Adverse Analytical Finding. If the Player or other Person rebuts the preceding presumption by showing that a departure from the International Standard for Laboratories occurred which could reasonably have caused the Adverse Analytical Finding, then World

Rugby shall have the burden to establish that such departure did not cause the Adverse Analytical Finding. [See [Comment 12](#)]

- 21.3.2.3** Departures from any other International Standard or other anti-doping rule or policy set forth in the Code or these Anti-Doping Rules which did not cause an Adverse Analytical Finding or other anti-doping rule violation shall not invalidate such evidence or results. If the Player or other Person establishes a departure from another International Standard or other anti-doping rule or policy which could reasonably have caused an anti-doping rule violation based on an Adverse Analytical Finding or other anti-doping rule violation, then World Rugby shall have the burden to establish that such departure did not cause the Adverse Analytical Finding or the factual basis for the anti-doping rule violation.
- 21.3.2.4** The facts established by a decision of a court or professional disciplinary tribunal of competent jurisdiction which is not the subject of a pending appeal shall be irrebuttable evidence against the Player or other Person to whom the decision pertained of those facts unless the Player or other Person establishes that the decision violated principles of natural justice.
- 21.3.2.5** The hearing panel in a hearing on an anti-doping rule violation may draw an inference adverse to the Player or other Person who is asserted to have committed an anti-doping rule violation based on the Player's or other Person's refusal, after a request made in a reasonable time in advance of the hearing, to appear at the hearing (either in person or telephonically as directed by the hearing panel) and to answer questions from the hearing panel or World Rugby.

## **21.4 THE PROHIBITED LIST**

### **21.4.1 Incorporation of the Prohibited List**

These Anti-Doping Rules incorporate the Prohibited List, which is published and revised by WADA as described in Article 4.1 of the Code. [See [Comment 13](#)]

Each Union is responsible for ensuring that the current Prohibited List is available to its members and constituents. The Prohibited List in force is available on WADA's website at [www.wada-ama.org](http://www.wada-ama.org) and is included in these Regulations as Schedule 2. In the event of any conflict, the Prohibited List appearing on the WADA website in English shall prevail.

### **21.4.2 Prohibited Substances and Prohibited Methods Identified on the Prohibited List**

#### **21.4.2.1 Prohibited Substances and Prohibited Methods**

Unless provided otherwise in the Prohibited List and/or a revision, the Prohibited List and revisions shall go into effect under these Anti-Doping Rules three months after publication by WADA, without requiring any further action by World Rugby or its Member Unions. All Players and other Persons shall be bound by the Prohibited List, and any revisions thereto, from the date they go into effect, without further formality. It is the

responsibility of all Players and other Persons to familiarise themselves with the most up-to-date version of the Prohibited List and all revisions thereto.

#### **21.4.2.2 Specified Substances**

For purposes of the application of Regulation 21.10, all Prohibited Substances shall be Specified Substances except substances in the classes of anabolic agents and hormones and those stimulants and hormone antagonists and modulators so identified on the Prohibited List. The category of Specified Substances shall not include Prohibited Methods. [See [Comment 14](#)]

#### **21.4.3 WADA's Determination of the Prohibited List**

WADA's determination of the Prohibited Substances and Prohibited Methods that will be included on the Prohibited List, the classification of substances into categories on the Prohibited List, and the classification of a substance as prohibited at all times or In-Competition only, is final and shall not be subject to challenge by a Player or other Person based on an argument that the substance or method was not a masking agent or did not have the potential to enhance performance, represent a health risk or violate the spirit of sport.

#### **21.4.4 Therapeutic Use Exemptions ("TUEs")**

**21.4.4.1** Players with a documented medical condition requiring the use of a Prohibited Substance or a Prohibited Method must first obtain a TUE. The International Standard for TUEs is set out in Schedule 3(a) and the World Rugby TUE application forms are set out in Schedule 3(b) of these Anti-Doping Rules.

**21.4.4.2** International-Level Players and any other Players prior to their participation in any International Match, Series of International Matches or International Tournament organised by World Rugby (as set out in Regulation 21.5.3.3) must obtain a TUE from World Rugby's TUE Committee in advance of the administration of the Prohibited Substance or, where they already have a TUE from their NADO, provide World Rugby's TUE Committee with a copy of such existing TUE certificate and application for review and recognition by World Rugby (pursuant to Regulation 21.4.5 (Mutual Recognition)) in accordance with Article 7 of the International Standard for Therapeutic Use Exemptions. If such Player does not already have a TUE granted by his NADO for the substance or method in question he must apply directly to World Rugby for a TUE in accordance with this Regulation 21.4.4. TUEs granted by World Rugby shall be reported in writing to the Player via the Player's Union and his NADO and additionally in respect of International-Level Players to WADA. TUE requests shall be evaluated by the World Rugby TUE Committee in accordance with the International Standard for TUEs set out in Schedule 3(a) of these Regulations. If World Rugby does not recognise a TUE granted by a NADO it shall notify the Player via the Player's Union and NADO promptly providing reasons. The Player or his NADO have 21 days from such notification to refer the matter to WADA for review.

- 21.4.4.3** Other Players subject to Testing must obtain a TUE from their NADO. TUE requests shall be evaluated in accordance with the International Standard for TUEs set out in Schedule 3(a) to these Regulations. [See [Comment 15](#)] [See [Comment 16](#)]
- 21.4.4.4** World Rugby shall appoint a panel of physicians to its TUE Committee. Upon World Rugby's receipt of a TUE request, the Chair of World Rugby's TUE Committee shall appoint one or more members of World Rugby's TUE Committee (which may include the Chair) to consider such request. World Rugby's TUE Committee member(s) so designated shall promptly evaluate such request in accordance with the International Standard for TUEs and render a decision on such request, which shall be the final decision of World Rugby, and which shall be reported to WADA and other relevant Anti-Doping Organisations through ADAMS, in accordance with the International Standard for Therapeutic Use Exemptions. The Chairman of World Rugby's TUE Committee may seek specialist advice from outside World Rugby's TUE Committee members or appoint specialists to sit on World Rugby's TUE Committee as and when deemed necessary for the purposes of evaluating a TUE.
- 21.4.4.5** Players in the Registered Testing Pool and the Testing Pool should apply to World Rugby for the TUE at the same time the Player first provides whereabouts information to World Rugby and, except in emergency situations, no later than 30 days before the Player's participation in an International Match, Series of International Matches, and/or International Tournament organised by World Rugby (as set out in Regulation 21.5.3.3).
- 21.4.4.6** Players participating in an International Match, Series of International Matches and/or International Tournament organised by World Rugby (as set out in Regulation 21.5.3.3) who are not included in World Rugby's Registered Testing Pool or Testing Pool must, except in emergency situations, request a TUE from World Rugby no later than 30 days before the Player's participation in an International Match, Series of International Matches and/or International Tournament so organised by World Rugby. [See [Comment 17](#)]
- 21.4.4.7** WADA, at the request of a Player or his NADO within 21 days of receipt of notification of the TUE Committee's decision or on its own initiation, may review the granting, denial or non-recognition of any TUE to an International-Level Player or a national level Player that is included in a Registered Testing Pool. If WADA determines that the granting, denial or non-recognition of a TUE did not comply with the International Standard for TUEs in force at the time then WADA may reverse that decision. Decisions on TUEs are subject to further appeal as provided in Regulation 21.4.7. If a Player or NADO refers a matter to WADA for review, in the case of a TUE granted by World Rugby, the TUE remains valid for international-level Competition and Out-of-Competition Testing (but is not valid for national-level Competition) pending WADA's decision, and in the case of a TUE from a NADO not recognised by World Rugby, the TUE remains valid for national-level Competition and Out of Competition Testing (but is not valid for international-level Competition) pending WADA's decision. If a matter is

not referred to WADA for review, upon the expiration of the 21-day review deadline, a TUE granted by World Rugby becomes valid for national-level Competition as well and a TUE from a NADO not recognised by World Rugby becomes invalid for any purpose. [See [Comment 18](#)]

**21.4.4.8** Presence of a Prohibited Substance or its Metabolites or Markers (Regulation 21.2.1), Use or Attempted Use of a Prohibited Substance or a Prohibited Method (Regulation 21.2.2), Possession of a Prohibited Substance or a Prohibited Method (Regulation 21.2.6) or Administration or Attempted Administration of a Prohibited Substance or Prohibited Method (Regulation 21.2.8) consistent with the provisions of an applicable TUE issued pursuant to the International Standard for TUEs shall not be considered an anti-doping rule violation.

#### **21.4.5 Mutual Recognition of TUEs**

Any International-Level Player who competes in the Tournaments listed in Regulation 21.5.3.3 and/or who is a member of the Registered Testing Pool or Testing Pool and who has been granted a TUE by a National or Other Anti-Doping Organisation's TUE Committee that is current and valid must submit a copy of the application and the certificate of approval to World Rugby's TUE Committee. This must be submitted in accordance with the timelines set out in Regulations 21.4.4.5 and 21.4.4.6. In accordance with the recognition provisions set out in Article 4.4 of the Code and Article 7 of the International Standard for TUEs such TUE approvals shall be accepted by World Rugby subject to the approval of World Rugby's TUE Committee in accordance with Regulation 21.4.4.2. World Rugby has the right to review and appeal all TUE approvals submitted to World Rugby's TUE Committee where approved by another Anti-Doping Organisation TUE Committee. World Rugby may publish as it considers appropriate a list of Anti-Doping Organisations whose TUE decisions, or certain categories of such decisions, it will automatically recognise in accordance with Article 7.1(a) of the International Standard for TUEs.

#### **21.4.6 Expiration, Cancellation, Withdrawal or Reversal of a TUE**

**21.4.6.1** A TUE granted pursuant to these Anti-Doping Rules: (a) shall expire automatically at the end of any term for which it was granted, without the need for any further notice or other formality; (b) may be cancelled if the Player does not promptly comply with any requirements or conditions imposed by the TUE Committee upon grant of the TUE; (c) may be withdrawn by the TUE Committee if it is subsequently determined that the criteria for grant of a TUE are not in fact met; or (d) may be reversed on review by WADA or on appeal.

**21.4.6.2** In such event, the Player shall not be subject to any Consequences based on his Use or Possession or Administration of the Prohibited Substance or Prohibited Method in question in accordance with the TUE prior to the effective date of expiry, cancellation, withdrawal or reversal of the TUE. The review pursuant to Regulation 21.7.2 of any subsequent Adverse Analytical Finding shall include consideration of whether such finding is consistent



with Use of the Prohibited Substance or Prohibited Method prior to that date, in which event no anti-doping rule violation shall be asserted.

#### **21.4.7 Reviews and Appeals of TUE Decisions**

**21.4.7.1** WADA shall review any decision by World Rugby not to recognise a TUE granted by the NADO that is referred to WADA by the Player or the Player's NADO. In addition, WADA shall review any decision by World Rugby to grant a TUE that is referred to WADA by the Player's NADO. WADA may review any other TUE decisions at any time, whether upon request by those affected or on its own initiative. If the TUE decision being reviewed meets the criteria set out in the International Standard for TUEs, WADA will not interfere with it. If the TUE decision does not meet those criteria, WADA will reverse it.

**21.4.7.2** Any TUE decision by World Rugby (or by a NADO where it has agreed to consider the application on behalf of World Rugby) that is not reviewed by WADA, or that is reviewed by WADA but is not reversed upon review, may be appealed by the Player and/or the Player's NADO, exclusively to CAS. [See [Comment 19](#)]

**21.4.7.3** A decision by WADA to reverse a TUE decision may be appealed by the Player, the NADO and/or World Rugby, exclusively to CAS.

**21.4.7.8** A failure by World Rugby, a Union or NADO to take action within a reasonable time on a properly submitted application for grant or recognition of a TUE or for review of a TUE decision shall be considered a denial of the application.

#### **21.4.8 Nutritional Supplements and Medications**

**21.4.8.1** The use of nutritional supplements by Players is a risk. In many countries regulations either do not exist or are limited in nature in relation to the manufacturing and labelling of supplements. This may lead to a supplement containing an undeclared substance that is prohibited under these Anti-Doping Rules. Nutritional supplements may not be regulated or could be contaminated or suffer from cross contamination or may not have all the ingredients listed on the product label. Players are advised to exercise extreme caution regarding the use of nutritional supplements.

**21.4.8.2** Many of the substances in the Prohibited List may appear either alone or as part of a mixture within medications or supplements which may be available with or without a doctor's prescription. Any Player who is concerned about the appropriateness of treatment being administered to him, or medications or supplements being ingested by him, should seek clarification from his doctor or other relevant authority as to whether such treatment is or such medications or supplements are prohibited prior to taking possession of or using such item. For the avoidance of doubt nothing herein shall displace the Player's responsibility to ensure he does not commit an anti-doping rule violation.

## **21.5 TESTING AND INVESTIGATIONS**

### **21.5.1 Purpose of Testing and Investigations**

Testing and investigations shall only be undertaken for anti-doping purposes. They shall be conducted in conformity with the provisions of the International Standard for Testing and Investigations and the Doping Control Procedural Guidelines in Schedule 1 to these Anti-Doping Rules which supplement that International Standard.

**21.5.1.1** Testing shall be undertaken to obtain analytical evidence as to the Player's compliance (or non-compliance) with the strict Code prohibition on the presence/Use of a Prohibited Substance or Prohibited Method. Test distribution planning, Testing, post-Testing activity and all related activities conducted by World Rugby shall be in conformity with the International Standard for Testing and Investigations. World Rugby shall determine the number of random tests and target tests to be performed, in accordance with the criteria established by the International Standard for Testing and Investigations. All provisions of the International Standard for Testing and Investigations shall apply automatically in respect of all such Testing.

**21.5.1.2** Investigations shall be undertaken:

**21.5.1.2.1** in relation to Atypical Findings, Atypical Passport Findings and Adverse Passport Findings, in accordance with Regulation 21.7.4 and 21.7.5 respectively, gathering intelligence or evidence (including, in particular, analytical evidence) in order to determine whether an anti-doping rule violation has occurred under Regulation 21.2.1 (Presence and/or 21.2.2 (Use or Attempted Use)); and

**21.5.1.2.2** in relation to other indications of potential anti-doping rule violations, in accordance with Regulation 21.7.6 and 21.7.7, gathering intelligence or evidence (including, in particular, non-analytical evidence) in order to determine whether an anti-doping rule violation has occurred under any of Regulation 21.2.2 (Use or Attempted Use) to 21.2.10 (Prohibited Association).

**21.5.1.3** World Rugby may obtain, assess and process anti-doping intelligence from all available sources, to inform the development of an effective, intelligent and proportionate test distribution plan, to plan Target Testing, and/or to form the basis of an investigation into a possible anti-doping rule violation(s).

### **21.5.2 Authority to conduct Testing**

**21.5.2.1** Subject to the jurisdictional limitations for Event Testing set out in Article 5.3 of the Code, World Rugby shall have In-Competition and Out-of-Competition Testing authority over all of the Players specified in the Introduction to these Anti-Doping Rules at point iii headed "Scope".

**21.5.2.2** World Rugby may require any Player over whom it has Testing authority (including any Player serving a period of Ineligibility) to provide a Sample at any time and at any place. Doping Control may be random or targeted

and all Players shall submit to Doping Control at any time and any place whenever requested by an authorised official. For the avoidance of doubt, this includes both In Competition and Out of Competition Doping Control. Out of Competition Doping Control shall be undertaken with or without prior notice ("No Advance Notice"). A Player may be selected to provide any number of Samples for Doping Control in any calendar year. World Rugby, and/or Unions shall be entitled to undertake Target Testing of Players. [See [Comment 20](#)]

- 21.5.2.3** WADA shall have In-Competition and Out-of-Competition Testing authority as set out in Article 20.7.8 of the Code.
- 21.5.2.4** World Rugby, the Union or Tournament Organiser (as the case may be) may appoint a NADO or any other third party that World Rugby deems suitable to collect Samples as part of Doping Control.
- 21.5.2.5** All Samples collected, whether by or for World Rugby, a Union, Tournament Organiser or any other third party shall be analysed at a WADA accredited laboratory.
- 21.5.2.6** All Samples collected by World Rugby or its designee, and the results of the analysis of such Samples, shall remain the property of World Rugby.
- 21.5.2.7** If World Rugby, a Union or Tournament Organiser delegates or contracts any part of Testing to a National Anti-Doping Organisation (directly or through a Member Union), that National Anti-Doping Organisation may collect additional Samples or direct the laboratory to perform additional types of analysis at the National Anti-Doping Organisation's expense. If additional Samples are collected or additional types of analysis are performed, World Rugby, the Union or Tournament Organiser shall be notified.

### **21.5.3 Event Testing**

- 21.5.3.1** Except as provided in Article 5.3 of the Code, only a single organisation should be responsible for initiating and directing Testing at Event Venues during an Event Period. At International Events, the collection of Samples shall be initiated and directed by World Rugby (or such other international organisation which is the ruling body for the Event, including without limitation an Association in the case of a regional event or a Union(s) in the case of an International Tournament or International Series of Matches managed by Union(s)). At the request of World Rugby (or such other international organisation which is the ruling body for an Event), any Testing during the Event Period outside of the Event Venues shall be coordinated with World Rugby (or the relevant ruling body of the Event).
- 21.5.3.2** If an Anti-Doping Organisation which would otherwise have Testing authority but is not responsible for initiating and directing Testing at an Event desires to conduct Testing of Players at the Event Venues during the Event Period, the Anti-Doping Organisation shall first confer with World Rugby (or any other international organisation which is the ruling body of the Event) to obtain permission to conduct and coordinate such Testing. If

the Anti-Doping Organisation is not satisfied with the response from World Rugby (or any other international organisation which is the ruling body of the Event), the Anti-Doping Organisation may ask WADA for permission to conduct Testing and to determine how to coordinate such Testing, in accordance with the procedures set out in the International Standard for Testing and Investigations. WADA shall not grant approval for such Testing before consulting with and informing World Rugby (or any other international organisation which is the ruling body for the Event). WADA's decision shall be final and not subject to appeal. Unless otherwise provided in the authorisation to conduct Testing, such tests shall be considered Out-of-Competition tests. Results management for any such test shall be the responsibility of the Anti-Doping Organisation initiating the test unless provided otherwise in the rules of the ruling body of the Event.

**21.5.3.3** Notwithstanding Regulations 21.5.3.1 and 21.5.3.2, World Rugby has exclusive responsibility for conducting or arranging Doping Controls including, but not limited to, determination of Sample collection during the Event Period, result management, the conduct of investigations and disciplinary proceedings and the imposition of sanctions for anti-doping rule violations, including cases where there has been no Doping Control carried out, in respect of:

- (a) Rugby World Cup Qualifying and Finals Tournaments;
- (b) Rugby World Cup Sevens Qualifying and Finals Tournaments;
- (c) Olympic Games Qualifying and Finals Tournaments (save with respect to Sample collection in accordance with the applicable protocols of the International Olympic Committee);
- (d) World Rugby Sevens Series;
- (e) Women's Rugby World Cup Qualifying and Finals Tournaments;
- (f) Age-grade World Championships;
- (g) Other World Rugby Tournaments;
- (h) Such other Matches or Tournaments as World Rugby shall from time to time determine; and
- (i) Such other occasions where World Rugby conducts Out of Competition Doping Controls.

**21.5.3.4** For Matches, International Tournaments and International Matches organised by World Rugby which shall be deemed to include the Rugby World Cup and Olympic Games (including qualifiers), modified and/or additional procedures and rules to those set out in Regulations 21.7 and 21.8.1 may be adopted by the Tournament Organiser or other body designated by World Rugby. These modified and/or additional procedures and rules shall be in compliance with the Code, as well as with the International Standard for Testing and Investigations.

**21.5.3.5** Subject to Regulation 21.5.3.6 below, in all other cases (except where Doping Control is carried out under the rules of another sporting body approved by World Rugby and the Unions concerned) the Union or Association (as determined by World Rugby) conducting or arranging the Doping Control, or in whose jurisdiction a Match, Tournament (including as part of a multi-sport games) or Series of Matches is held, will be responsible for the conduct of Doping Controls (subject to any applicable rules and regulations of the multi-sports games), results management, the conduct of investigations and disciplinary proceedings and the imposition of sanctions for anti-doping rule violations.

**21.5.3.6** Responsibility for conducting or arranging Doping Controls including, but not limited to, determination of Sample collection, results management, the conduct of investigations and disciplinary proceedings and the imposition of sanctions for anti-doping rule violations, including cases where there has been no Doping Control carried out, in respect of:

- (a) International Matches; and
- (b) International Tours; may subject to strict compliance with these Anti-Doping Rules and Guidelines be delegated to the Host Union; and in respect of;
- (c) International Tournaments (save as set out in Regulation 21.5.3.3 and 21.5.3.4 above); or
- (d) other Tournaments,

may, subject to strict compliance with these Anti-Doping Rules and Guidelines, and the consent of the Unions concerned be delegated to the International Tournament Organiser or other Tournament Organisers (as the case may be).

#### **21.5.4 Test Distribution Planning**

Consistent with the International Standard for Testing and Investigations, and in coordination with other Anti-Doping Organisations conducting Testing on the same Players, World Rugby shall develop and implement effective, intelligent and proportionate test distribution plans that prioritises appropriately between fifteens and sevens, men's and women's, senior and age-grade Players, types of Testing, types of Samples collected, and types of Sample analysis, all in compliance with the requirements of the International Standard for Testing and Investigations. World Rugby shall provide WADA upon request with a copy of its current test distribution plan.

#### **21.5.5 Coordination of In Competition and Out of Competition Doping Controls**

**21.5.5.1** Each Union must include within its regulations the following provisions:

- (a) A provision that entitles the Union to conduct both In Competition and Out of Competition Doping Control on a No Advance Notice basis or otherwise;

- (b) A provision allowing World Rugby, WADA, its NADO and Anti-Doping Organisations to conduct Out of Competition Doping Control on a No Advance Notice basis or otherwise on Players within or under that Union's jurisdiction; and
- (c) A provision allowing World Rugby, WADA, its NADO and Anti-Doping Organisations to conduct Doping Control on Players at Matches that form part of a Union's national competitions or similar events.

**21.5.5.2** Each Union shall make it a condition of membership and a condition of participation in its competitions that the Participants and other Persons in membership agree to be subject to these Anti-Doping Rules including an agreement to be subject to In Competition and Out of Competition Doping Control on a No Advance Notice basis or otherwise by the Union, World Rugby, WADA, NADO and Anti-Doping Organisations.

**21.5.5.3** The nature of Out of Competition Doping Control makes it desirable that no prior warning is given to the Player being tested. When an Out of Competition Doping Control is undertaken reasonable efforts will be made to avoid interruption to a Player's training, however, neither World Rugby, Unions, or its or their designees, shall be liable for any inconvenience or loss resulting from Out of Competition Doping Control whether on a No Advance Notice basis or otherwise.

**21.5.5.4** It is the duty of each Union to assist World Rugby and, where applicable, other Unions in undertaking Doping Controls. Any Union preventing, hindering or otherwise obstructing the carrying out of such Doping Control shall be subject to disciplinary action by World Rugby. Any Rugby Body or Club that prevents, hinders or otherwise obstructs the carrying out of any Doping Control shall be subject to disciplinary action by its Union.

**21.5.5.5** Without prejudice to the requirement on Unions to notify all anti-doping rule violations in accordance with the provisions of Regulation 21.7.12.3 and 21.7.12.4 each Union must submit to World Rugby every 12 months and/or when requested by World Rugby a report of all Doping Controls undertaken and a summary of the results of those Doping Controls.

**21.5.5.6** Each Union is responsible for ensuring in relation to its own anti-doping programme and the implementation of these Anti-Doping Rules that any and all applicable data regulation clearances and medical confidentiality clearances and consents relating to, without limitation, disclosure and distribution of whereabouts information, analysis results, medical information and findings and decisions of hearings are obtained for the benefit of and use by the Union, World Rugby, NADO and WADA.

**21.5.5.7** Where reasonably feasible, Testing shall be coordinated through ADAMS or another system approved by WADA in order to maximise the effectiveness of the combined Testing effort and to avoid unnecessary repetitive Testing.

## **21.5.6 Player Whereabouts for Out of Competition Testing**

**21.5.6.1** World Rugby will establish an Out of Competition Testing programme based on the ranking of Unions that participate in World Rugby

Tournaments (this may include but not be limited to Rugby World Cup, qualifying Tournaments for the Olympic Games, Rugby World Cup Sevens, Women's Rugby World Cup and World Rugby age-grade championships) and select a number of Players who are eligible for inclusion per Union. World Rugby shall develop a global whereabouts policy for the Game which shall be applied consistently across all Unions and Players involved in World Rugby's Out of Competition Testing programme. World Rugby will also establish criteria for Players to be placed into a Registered Testing Pool and Testing Pool who are subject to the provision of Player whereabouts information for the purpose of No Advance Notice Out of Competition Testing. Players in the Registered Testing Pool will be required to comply with the whereabouts requirements of Annex I to the International Standard for Testing and Investigations. World Rugby shall make available through ADAMS, a list which identifies those Players included in its Registered Testing Pool either by name or by clearly defined, specific criteria. World Rugby shall coordinate with Unions and/or National Anti-Doping Organisations the identification of such Players and the collection of their whereabouts information. World Rugby shall review and update as necessary its criteria for including Players in its Registered Testing Pool, and shall revise the membership of its Registered Testing Pool from time to time as appropriate in accordance with the set criteria.

#### **21.5.6.2 Registered Testing Pool**

- (a) The Registered Testing Pool shall be considered a high risk pool of Players whose entry into this pool shall be based on their individual or collective behaviour in relation to doping and compliance with the whereabouts requirements of the Testing Pool and World Rugby's Out of Competition Testing programme.
- (b) Players shall be notified before they are included in the Registered Testing Pool and when they are removed from that pool. Each Player in the Registered Testing Pool shall do the following, in each case in accordance with Annex I to the International Standard for Testing and Investigations: (a) advise World Rugby of his whereabouts on a quarterly basis; (b) update that information as necessary so that it remains accurate and complete at all times; and (c) make himself available for Testing at such whereabouts (notwithstanding the requirement to be available for Sample collection at all times pursuant to Regulation 21.22.1.2).
- (c) Players entered into the Registered Testing Pool will be required to provide accurate, complete and updated whereabouts information to World Rugby (and/or their NADO as agreed by World Rugby) for each day in the forthcoming quarter via their Union and/or ADAMS (if applicable) for the purpose of No Advance Notice Out of Competition Testing. Such whereabouts information shall include, without limitation, the Player identifying where he will be living, training and competing so that he can be located for Testing during that quarter at the times and locations specified and, in addition, one specific 60-minute slot between 6am and 11pm each day where the Player will

be available at a specific location for Testing, notwithstanding the provision of his whereabouts information outside of that 60-minute time slot.

- (d) Entry into the Registered Testing Pool will be based on the criteria outlined in Regulation 21.5.6.4. World Rugby may revise its Registered Testing Pool from time to time as appropriate.
- (e) Players who are members of the Registered Testing Pool of their NADO, and whose Union is part of World Rugby's Out of Competition Testing programme shall remain part of the Testing Pool unless those Players fulfil the criteria outlined in Regulation 21.5.6.4. World Rugby will liaise with NADOs for the purposes of World Rugby's Out of Competition Testing programme to ensure a coordinated approach to the application of its global whereabouts policy and procedures.

### **21.5.6.3 Testing Pool**

- (a) In addition to the Registered Testing Pool described in Regulation 21.5.6.2 above, World Rugby shall identify a Testing Pool of International-Level Players who will be required to provide up to date whereabouts information to World Rugby for each quarter period via their Union and/or ADAMS (if applicable) and/or NADO (if agreed by World Rugby) for the purpose of No Advance Notice Out of Competition Testing. World Rugby may revise its Testing Pool from time to time as appropriate.
- (b) The Testing Pool shall be the principal pool of Players eligible for Out of Competition Testing by World Rugby; and
- (c) Players may be moved between the Registered Testing Pool and the Testing Pool or vice versa at World Rugby's discretion taking into account the criteria outlined at Regulation 21.5.6.4 and 21.5.6.5. Players who are moved into or transferred between the Registered Testing Pool and/or the Testing Pool will be notified in writing by World Rugby via their Union of their inclusion in the relevant Testing Pool.

### **21.5.6.4 Registered Testing Pool Criteria**

Satisfaction of any one of the criteria below may result in a Player becoming part of the Registered Testing Pool:

- (a) Players who are members of the Registered Testing Pool of a NADO and who would ordinarily be members of the Testing Pool may be included in the Registered Testing Pool at the sole discretion of World Rugby;
- (b) Players under World Rugby's jurisdiction who are serving periods of Ineligibility or who have recently completed a period of Ineligibility;
- (c) Players who have committed at least three whereabouts failures (any combination of filing failures or missed tests) whilst part of the Testing Pool within a 12-month period. The 12-month period starts to run on



the date that the Player commits the first whereabouts failure being relied upon by World Rugby for the purpose of elevating the Player to the Registered Testing Pool. For the avoidance of doubt such Players shall not carry forward any filing failures or missed tests accumulated in the Testing Pool on entering the Registered Testing Pool;

- (d) Any Player in respect of whom World Rugby undertakes an investigation following receipt of reliable intelligence regarding possible involvement in any aspect of doping; and
- (e) Any other Players at the discretion of World Rugby.

#### **21.5.6.5 Testing Pool Criteria**

World Rugby shall nominate which Unions and the number of International Level Players who are part of the Union's national squad that shall become part of the Testing Pool. For the avoidance of doubt, those Players who are part of the Registered Testing Pool shall not also be members of the Testing Pool.

#### **21.5.6.6 Removal from the Registered Testing Pool or Testing Pool**

A Player shall remain part of the Registered Testing Pool or Testing Pool for the duration of the nominated quarter and subject to whereabouts requirements set out in these Anti-Doping Rules unless and until:

- (a) The Player is given written notice by World Rugby or Union (in accordance with World Rugby's instructions) that he is no longer designated for inclusion in the Registered Testing Pool or Testing Pool;
- (b) Subject to Regulation 21.5.7.6, the Player retires from competition and gives written notice to his Union to that effect, who shall advise World Rugby immediately;
- (c) World Rugby at its discretion accepts a replacement whereabouts filing by a Union in respect of its National Squad for that quarter period.

#### **21.5.6.7 Movement of Players from the Registered Testing Pool to the Testing Pool**

A Player may be moved from the Registered Testing Pool to the Testing Pool where:

- (a) The Player has served a period of Ineligibility and has not given any cause to World Rugby, pursuant to Regulation 21.5.6.4 to remain in the Registered Testing Pool;
- (b) The Player was previously elevated from the Testing Pool into the Registered Testing Pool as a result of incurring three whereabouts failures and did not record any whereabouts failures in the Registered Testing Pool for a period of three consecutive quarters; and

- (c) World Rugby considers in its discretion that it is appropriate to move the Player from the Registered Testing Pool to the Testing Pool.

#### **21.5.6.8 Provision of Whereabouts**

- (a) International-Level Players entered into either the Registered Testing Pool or Testing Pool shall provide accurate and complete Player whereabouts information every quarter via their Union and/or ADAMS (or such other centralised database of similar functionality and security which World Rugby has access to and has approved) ("Database") to World Rugby (and/or their NADO as agreed by World Rugby in the notified format). Such information shall be forwarded to World Rugby by the Union (and/or their NADO if agreed by World Rugby) and/or via ADAMS (or such other Database) by the due dates outlined in Regulation 21.5.6.10. A failure by a Player in the Registered Testing Pool to submit his Player whereabouts by the deadline may amount to a filing failure and consequently a whereabouts failure as per Regulation 21.2.4. It shall not be a defence to an allegation of a filing failure under Regulation 21.2.4 (Whereabouts Failures) that the Player delegated such responsibility to a third party and that such third party failed to comply with the applicable requirements. A failure by a Player in the Testing Pool to submit his Player whereabouts by the deadline may amount to a filing failure but will only count towards elevation of the Player into the Registered Testing Pool.
- (b) World Rugby will also request an update on Player whereabouts from the applicable Union where World Rugby becomes aware that a Player's whereabouts details are incorrect (whether following an unsuccessful attempt or otherwise). Players and Unions shall also update World Rugby (and/or their NADO as agreed by World Rugby) as soon as practicably possible with any changes to or additional information in relation to the provided Player whereabouts that occur within the quarter period.

#### **21.5.6.9 Whereabouts Filing Requirements**

Before the last day of each quarter and prior to the first day of the following quarter (i.e. 1 January, 1 April, 1 July, 1 October respectively) a Player in either the Registered Testing Pool or the Testing Pool must file a whereabouts filing with World Rugby or its nominee (as agreed) via its Union and/or ADAMS (if applicable) that contains at least the following information:

- (a) A complete mailing address where correspondence may be sent to the Player via his Union for formal notice purposes. Any notice or other item sent by courier or registered post to that address will be deemed to have been received by the Player either by confirmed receipt of an email or fax from the Player (or his nominee) or his Union or when proof of actual receipt is provided by the delivery service or otherwise five working days after it was deposited in the mail. The

availability of such information does not relieve the Union from fulfilling their notification obligations pursuant to Regulation 21;

- (b) For each day during the following quarter, the full address of the place where the Player will be residing (e.g. home, temporary lodgings, hotel or holiday location, etc.). Where a Player's place of residence is situated within a restricted and/or secure location without ready access from the street to the residence the Player must provide instructions in his whereabouts filing setting out how authorised Doping Control Officers can gain access to the restricted and/or secure location with No Advance Notice. An unsuccessful attempt to test the Player as a result of the Doping Control Officer not being able to gain entry to the restricted and/or secure location where the Player resides may be considered a missed test;
- (c) For each day during the following quarter, the name and address of each location where the Player will train individually or as part of a Team activity under the supervision of the Team management (which may include for example gym work, physiotherapy, and/or medical treatment) this includes both his club and national Team schedules, work or conduct of any other regular activity (e.g. university or study), as well as the usual time-frames and venues for such regular activities; and
- (d) The Player's competition schedule for the following quarter, including the name and address of each location where the Player is scheduled to compete during the quarter and the date(s) on which he is scheduled to compete at such location(s). This includes both his club and national Team schedules.

#### **21.5.6.10 Whereabouts Filing for Registered Testing Pool Players – 1 hour rule**

In addition to the requirements of Regulation 21.5.6.9 above, the whereabouts filing for all Players who are part of the Registered Testing Pool must also include, for each day during the following quarter, one specific 60-minute slot between 6am and 11pm each day where the Player will be available and accessible for Testing at a specific location. This 60-minute time slot may be during any Team activity, (individual or group) conducted on the day in question.

#### **21.5.6.11 Whereabouts Filing for Testing Pool Players – Off Season Period**

Notwithstanding the requirements of Regulation 21.5.6.9 above:

- (a) The whereabouts filing for Players who are part of the Testing Pool during the off season period must for each day during the off season period (starting from the specified date in which the Player is relieved from any scheduled Team activities and ending upon the date he returns to scheduled Team activities), provide a nominated residence and the dates in which the Player will be present at the nominated residence. The provisions at (c) and (d) below shall apply equally to such Players;

- (b) Should a Player not be available at his normal nominated residence then an additional residence(s) and corresponding dates shall be provided. This includes any holiday locations such as hotels;
- (c) The default time in which a DCO shall attempt a test a Player at the Player's nominated residence shall be between 6am and 7am (default hour). If the Player is not available during the default hour the DCO will make reasonable attempts to obtain additional information during the default hour in an attempt to locate the Player during that attempt. However, failure to be available for Testing during the default hour at the nominated residence and following reasonable attempts by the DCO to obtain further information in order to test the Player during that test attempt, may be deemed a missed test which shall go towards the elevation of the Player into the Registered Testing Pool;
- (d) If a Player knows he will not be available at the nominated residence during the default hour period on any particular day(s), then the Player shall update his whereabouts (either to World Rugby or if agreed to his NADO) prior to the start of the default hour to avoid the possibility of recording a missed test. The Player shall specify an alternate one hour period where he will be available for Testing at a nominated residence or location. If the Player cannot be located during the nominated one hour period the DCO shall make reasonable attempts to obtain additional information during the nominated hour in an attempt to locate the Player during that test attempt. However, failure to be available for Testing during the nominated hour at the nominated residence or location and following reasonable attempts by the DCO to obtain further information to test the Player (during that test attempt) may be deemed a missed test which shall go towards the elevation of the Player into the Registered Testing Pool.

#### **21.5.6.12 Whereabouts Filing for Testing Pool Players – Periods of Absence from Scheduled Team Activities**

A Player in the Testing Pool who is not present at scheduled Team activities due to injury, illness or for any personal or other reasons during the season or where there is a break from scheduled Team activities during the season shall be required to be available and accessible for Testing at their nominated residence. The provisions at (c) and (d) above shall apply equally to such Players.

#### **21.5.6.13 Provision of Fraudulent Whereabouts Filing Information**

Any Player who provides fraudulent information in his whereabouts filing, whether in relation to his location during the specified daily 60-minute time slot, or in relation to his whereabouts outside that time slot, or otherwise, thereby commits an anti-doping rule violation under Regulation 21.2.3 (evading Sample collection) and/or Regulation 21.2.5 (Tampering or Attempted Tampering with Doping Control).

#### **21.5.6.14 Player Responsibility for Whereabouts**

- (a) The ultimate responsibility for providing whereabouts information rests with each Player. Players when making a whereabouts filing, are solely responsible for ensuring that they provide all of the information required accurately and in sufficient detail to enable World Rugby or Union or its nominee or NADO to locate the Player for Testing on any given day in the quarter.
- (b) It is the Player's responsibility to be available for Testing at all times in accordance with the whereabouts information declared on his whereabouts filing regardless of whether the Player makes the whereabouts filing personally or delegates it to a third party.

#### **21.5.6.15 Responsibilities of Unions with respect to Whereabouts Filings**

- (a) Without prejudice to Regulation 21.5.6.14 above, it shall be the responsibility of all applicable Unions to use their best efforts to assist World Rugby (and their NADO) in obtaining and providing updates of whereabouts information as changes occur and/or when requested by World Rugby and in assisting World Rugby in the implementation of its Out of Competition Testing programme.
- (b) Any Union which fails to provide timely Player whereabouts information as identified in Regulations 21.5.6.9 to 21.5.6.12 (whether to World Rugby and/or their NADO as applicable) and/or which fails to assist World Rugby in the implementation of its Out of Competition Testing programme may be subject to disciplinary action in accordance with World Rugby Regulation 18.
- (c) Each Union shall also assist, as appropriate, its NADO in establishing a national level testing pool of top level national Players who may or may not already be included in either the Registered Testing Pool or Testing Pool.

#### **21.5.6.16 Unsuccessful Attempt to Test**

- (a) If a Player in either a Registered Testing Pool or Testing Pool is not available for Testing following attempt(s) by a Doping Control Officer (duly documented and as outlined in Regulation 21.5.6.23 or 21.5.6.24) and has not updated his whereabouts filing prior to the Doping Control Officer attempting to test at the location(s) specified in the available whereabouts filing, that shall amount to an unsuccessful attempt.
- (b) World Rugby shall review each unsuccessful attempt to determine based on the criteria outlined in Regulation 21.5.6.23, for Players in the Registered Testing Pool, whether the unsuccessful attempt amounts to a missed test. Each missed test constitutes a whereabouts failure for the purposes of Regulation 21.2.4 (Whereabouts Failures).

- (c) World Rugby shall review each unsuccessful attempt to determine based on the criteria outlined in Regulation 21.5.6.24, for Players in the Testing Pool, whether the unsuccessful attempt amounts to a missed test. Each Testing Pool missed test will be considered for the purposes of determining if the Player meets the criteria in Regulation 21.5.6.4 for elevation to the Registered Testing Pool. Any missed tests or filing failures accumulated by a Player in the Testing Pool will not be counted for the purposes of Regulation 21.2.4 (Whereabouts Failures) if the Player is elevated to the Registered Testing Pool.
- (d) It shall not be a defence to an allegation of a missed test under Regulation 21.2.4 (Whereabouts Failures) that the Player had delegated responsibility for filing his whereabouts information for the relevant period to a third party and that third party had failed to file the correct information or failed to update previously filed information to ensure that the whereabouts information in the whereabouts filing for the day in question was current and accurate.

#### **21.5.6.17 Consequences of Whereabouts Failures**

- (a) Registered Testing Pool: Any Player in a Registered Testing Pool who commits a total of three whereabouts failures (which may be any combination of filing failures and/or missed tests adding up to three in total) within a 12-month period, (irrespective of which Anti-Doping Organisation(s) has/have declared the whereabouts failures in question) shall be considered to have committed an anti-doping rule violation pursuant to Regulation 21.2.4.
- (b) Testing Pool: Any Player in a Testing Pool who commits a total of three whereabouts failures (which may be a combination of a filing failure(s) and/or missed test(s)) within a 12-month period shall be automatically transferred from the Testing Pool to the Registered Testing Pool. Upon the occurrence of such an event any missed test(s) or filing failure(s) incurred in the Testing Pool will not be carried forward into the Registered Testing Pool. Once the Player enters the Registered Testing Pool he will be subject to the supplemental whereabouts provisions of Regulation 21.5.6.10.

The 12-month period referred to in (a) and (b) above starts to run on the date that the Player commits the first whereabouts failure being relied upon by World Rugby for the purpose of elevating the Player to the Registered Testing Pool or alleging an anti-doping rule violation pursuant to Regulation 21.2.4. It is not affected by any successful Sample collection conducted with respect to that Player during the 12-month period, i.e. if three Whereabouts Failures occur during the 12-month period then an anti-doping rule violation is committed in accordance with Regulation 21.2.4 (Whereabouts Failures) irrespective of any Samples successfully collected from a Player during that 12-month period. However, if a Player who has committed one whereabouts failure does not go on to commit a further two whereabouts failures within 12 months of the first, at the end of that 12-month period the first whereabouts failure “expires” for the purpose of

Regulation 21.5.6.17. For the purposes of determining whether a whereabouts failure has occurred within the 12-month period referred to in Regulation 21.5.6.17:

- (a) A filing failure shall be deemed to have occurred on the first day of the quarter for which the Player fails to make the required filing, or in the case of any subsequent filing failure in the same quarter following notice of the previous filing failure where the Player failed to rectify that filing failure by the deadline specified in that notice; and
- (b) A missed test will be deemed to have occurred on the date that the Sample collection was unsuccessfully attempted.
- (c) For the avoidance of doubt, for the purposes of Regulation 21.2.4, a failure to comply with the International Standard for Testing and Investigations shall be deemed a filing failure or a missed test (as defined in the International Standard for Testing and Investigations) where the conditions set forth in the International Standard for Testing and Investigations for declaring a filing failure or missed test are met.

#### **21.5.6.18 Filing Failure Pre-Conditions**

A Player may only be declared to have committed a filing failure where World Rugby, Union or NADO following the results management procedure set out in Regulation 21.5.6.26, can establish each of the following:

- (a) That the Player was duly notified via his Union (i) that he was designated for inclusion in a Registered Testing Pool or Testing Pool, (ii) of the consequent requirement to make and update accurate whereabouts filings, and (iii) of the consequences of any failure to comply with that requirement;
- (b) That the Player failed to comply with any or all of the requirements to make and update accurate whereabouts filings by the applicable deadline or at any time during the quarter if the circumstances and/or location(s) in relation to his whereabouts changed;
- (c) That in the case of a second or third filing failure in the same quarter, the Player was given notice of the previous filing failure via his Union in accordance with Regulation 21.5.6.26 and failed to rectify that filing failure by the deadline specified in that notice; and
- (d) That the Player's failure to comply was at least negligent. For these purposes, the Player will be presumed to have committed the failure negligently upon proof that he was notified of the requirement yet failed to comply with it. That presumption may only be rebutted by the Player establishing that no negligent behaviour on his part caused or contributed to the failure.

#### **21.5.6.19 Third Party Provision of Whereabouts Filings**

- (a) A Player in a Registered Testing Pool or Testing Pool may choose to delegate the making of some or all of his whereabouts filings required

under Regulation 21.5.6.9 to 21.5.6.12 (and/or any updates to his whereabouts filings required under Regulation 21.5.6.22) to a third party such as his Union or his Team management or club provided that the third party agrees to such delegation. This may include periods of Team activity but also in respect of periods where the Player is not with the Team, provided the Team management or Union agrees. Without prejudice to Regulations 21.7.12 to 21.7.14 and 21.23, the Union shall be responsible for the collection of such information from the Player, the Player's club and/or Team prior to it being forwarded to World Rugby or its nominee save where ADAMS is applicable.

- (b) For Players in a Registered Testing Pool or Testing Pool, where the Union makes the whereabouts filing, liability for filing failures shall be determined in accordance with Regulation 21.5.6.18, and liability for missed tests shall be determined in accordance with Regulation 21.5.6.23 or 21.5.6.24 (as appropriate).

#### **21.5.6.20 Consequence of Third Party Filing Failures**

- (a) If the Union or other authorised third party does not make a required whereabouts filing, or makes the whereabouts filing but does not include all of the required information, then (subject to the requirements of Regulation 21.5.6.18) the Player will be liable for a filing failure.
- (b) If any of the required information changes after a whereabouts filing is made, then in accordance with Regulation 21.5.6.22, an update must be filed by an authorised third party so that the whereabouts filing remains accurate at all times.
- (c) For Players in the Registered Testing Pool, if an update is not made by an authorised third party, and as a result an attempt to test the Player during the 60-minute time slot is unsuccessful then (subject to the requirements of Regulation 21.5.6.23) the Player will remain liable for a missed test under Regulation 21.5.6.27.
- (d) For Players in the Testing Pool if an update to a whereabouts filing is not made by an authorised third party, and as a result an attempt to the test the Player within a 24-hour period is unsuccessful, then (subject to the requirements of Regulation 21.5.6.24) the Player will remain liable for a missed test under Regulation 21.5.6.27.

#### **21.5.6.21 Availability for Testing – Registered Testing Pool and Testing Pool**

- (a) A Player in the Registered Testing Pool must specifically be present and available for Testing on any given day in the relevant quarter for the 60-minute time slot specified for that day in his whereabouts filing, at the location that the Player has specified for that time slot in such filing. If a Player fails to remain at the nominated location for the full 60-minute period he runs the risk of a potential missed test if the DCO arrives during the 60-minute period but after the Player's departure.



- (b) A Player in the Testing Pool must specifically be present and available for Testing at any one of his specified locations in his whereabouts filing during the nominated time period over a 24-hour period on any given day during the season. This shall include at a minimum nominated Team activities (Club, Rugby Body and/or national Team) and nominated residential address. The 24-hour period is deemed to commence from when the DCO arrives at the first specified location in the whereabouts filing. The DCO shall ordinarily only visit each whereabouts location once unless the DCO obtains additional information which may result in the Player being located at a later time within that 24-hour period.
- (c) A Player in the Testing Pool must be present and available at his nominated residence or location in accordance with Regulation 21.5.6.11(c) and (d) and 21.5.6.12 for Testing during his off season and during any period of the season where he is not present at scheduled Team activities due to injury, illness or for any personal or other reasons or where there is a break from scheduled Team activities. The default hour in which a DCO shall attempt to test a Player at his nominated residence shall be between 6am and 7am unless otherwise advised by the Player.

**21.5.6.22** It is a Player's responsibility to ensure (including by updates, where necessary) that the whereabouts information provided in his whereabouts filing is sufficient to enable World Rugby or its nominee, Union or NADO to locate him for Testing within the periods specified in Regulation 21.5.6.21(a) or (b). Where any change in circumstances means that the information previously provided by or on behalf of the Player (whether in the initial whereabouts filing or in any subsequent update) is no longer accurate or complete the Player must update his whereabouts filing so that the information on file becomes accurate and complete. The Player must make such update as soon as possible, and for those Players in a Registered Testing Pool prior to the 60-minute time slot specified in his filing for that day. A failure to do so shall have the following consequences:

- (a) If, as a result of such failure, World Rugby or its nominee, Union or NADO's attempt to test the Player (who is part of a Registered Testing Pool) during the 60-minute time slot is unsuccessful, then the unsuccessful attempt shall be pursued as an apparent missed test in accordance with Regulation 21.5.6.27;
- (b) If, as a result of such failure, World Rugby or its nominee, Union or NADO's attempt to test the Player (who is part of the Testing Pool) at all of his nominated whereabouts locations specified in his whereabouts filing within a 24-hour period is unsuccessful, (or at the default hour or nominated one hour period during the off season or period of injury or illness) then the unsuccessful attempt shall be pursued as an apparent missed test in accordance with Regulation 21.5.6.27;

- (c) If the circumstances so warrant, the failure may be pursued as evasion of Sample collection under Regulation 21.2.3 (Evading) and/or Tampering or Attempted Tampering with Doping Control under Regulation 21.2.5 (Tampering); and
- (d) In any event, World Rugby or its nominee, Union or NADO shall consider Target Testing of the Player.

#### **21.5.6.23 Missed Test – Registered Testing Pool**

A Player in the Registered Testing Pool may only be declared to have committed a missed test where World Rugby, Union or NADO, following the results management procedure set out in Regulation 21.5.6.27, can establish each of the following:

- (a) That the Player who is in the Registered Testing Pool was given notice (including via his Union) that he had been designated for inclusion in the Registered Testing Pool and was advised of his liability for a missed test if he was unavailable for Testing during the 60-minute time slot specified in his whereabouts filing at the location specified for that time slot;
- (b) That the DCO attempted to test the Player who is in the Registered Testing Pool on a given day in the quarter, during the 60-minute time slot specified in the Player's whereabouts filing for that day, by visiting the location specified for that time slot;
- (c) That during that specified 60-minute time slot, the DCO did what was reasonable in the circumstances (i.e. given the nature of the specified location) to try to locate the Player, short of giving the Player any Advance Notice of the test;
- (d) That the provisions of Regulation 21.5.6.25 (if applicable) have been met; and
- (e) That the Player's failure to be available for Testing at the specified location during the specified 60-minute time slot was at least negligent. For these purposes, the Player will be presumed to have been negligent upon proof of the matters set out at Regulation 21.10.23 (a) to (d). That presumption may only be rebutted by the Player establishing that no negligent behaviour on his part caused or contributed to him (i) being unavailable for Testing at such location during such time slot; and (ii) failing to update his most recent whereabouts filing to give notice of a different location where he would instead be available for Testing during a specified 60-minute time slot on the relevant day.

#### **21.5.6.24 Missed Test - Testing Pool**

A Player in the Testing Pool may only be declared to have committed a missed test where World Rugby, Union or NADO, following the results

management procedure set out in Regulation 21.5.6.27, can establish each of the following:

- (a) That the Player who is in the Testing Pool was given notice that he had been designated for inclusion in the Testing Pool and was advised of his liability for a missed test if he was unavailable for Testing at all of his nominated whereabouts locations specified in his whereabouts filing within a 24-hour period during the season or at the default hour or nominated one hour period during the off season or period of injury or illness;
- (b) That the DCO attempted to test the Player who is in the Testing Pool within a 24-hour period in the quarter at all of his whereabouts locations as specified in his whereabouts filing, by visiting the specified locations at the specified times during the season or at the default or nominated one-hour period during the off season or period of injury or illness;
- (c) That within the 24-hour period (or during the default hour or nominated one hour period for the off season or period of injury or illness), the DCO did what was reasonable in the circumstances (i.e. given the nature of the specified locations) to try to locate the Player, with No Advance Notice of the test;
- (d) That the provisions of Regulation 21.5.6.25 (if applicable) have been met; and
- (e) That the Player's failure to be available for Testing at the specified locations during the specified dates/times within a 24-hour period (or at the default hour or nominated one hour period during the off season or period of injury or illness) was at least negligent. For these purposes, the Player will be presumed to have been negligent upon proof of the matters set out at Regulation 21.5.6.24 (a) to (d). That presumption may only be rebutted by the Player establishing that no negligent behaviour on his part caused or contributed to him (i) being unavailable for Testing at any location within any 24-hour period (or at the default hour or nominated one-hour period during the off season or period of injury or illness; and (ii) failing to update his most recent whereabouts filing to give notice of a different location/s, time period where he would instead be available for Testing on the relevant day.

**21.5.6.25** To ensure fairness to the Player, where an unsuccessful attempt has been made to test a Player in accordance with the provisions for the Registered Testing Pool or Testing Pool any subsequent attempt to test that Player (by World Rugby or its nominee, Union or NADO or any other Anti-Doping Organisation including WADA) may only be counted as an additional missed test against that Player if that subsequent attempt takes place after the Player has received notice, in accordance with this Regulation of the original unsuccessful attempt and given the opportunity to update his whereabouts filing within 24 hours of having received written notice of his apparent missed test. For the avoidance of doubt, where the Player does

not update his whereabouts filing within such 24-hour period this may be considered to be a filing failure pursuant to Regulation 21.5.6.18(b).

#### **21.5.6.26 Results Management for Filing Failures**

- (a) If it appears that all of the Regulation 21.5.6.18 requirements relating to filing failures are satisfied, then ordinarily no later than 14 days after the date of discovery of the apparent filing failure World Rugby shall send notice in writing to the Player via his Union of the apparent filing failure, inviting a response within 14 days of the date of the notice. In the notice, World Rugby shall warn the Player:
  - (i) That unless the Player persuades World Rugby that there has not been any filing failure, then (subject to the remainder of the results management process set out below) an alleged whereabouts failure will be recorded against the Player; and
  - (ii) (If applicable) that there are other whereabouts failures that have been alleged against him in the 12-month period prior to this alleged whereabouts failure; and
  - (iii) Of the consequences to the Player if a designee of World Rugby or a Judicial Officer or Judicial Committee in the case of a third whereabouts failure, upholds the alleged whereabouts failure.
- (b) Where the Player disputes the apparent filing failure, World Rugby must re-assess whether all of the Regulation 21.5.6.18 requirements are met. World Rugby must advise the Player and/or his Union, by letter sent ordinarily no later than 14 days after receipt of the Player's response, whether or not it maintains that there has been a filing failure.
- (c) If no response is received from the Player by the relevant deadline, or if World Rugby maintains (notwithstanding the Player's response) that there has been a filing failure, World Rugby shall send notice to the Player and/or his Union that an alleged filing failure is to be recorded against him. Further:
  - (i) In respect of Registered Testing Pool Players only, World Rugby shall at the same time advise the Player that he has the right to request an administrative review of the alleged filing failure;
  - (ii) In respect of Testing Pool Players, there is no administrative review as the filing failure will only count for the purposes of elevating the Player to World Rugby's Registered Testing Pool; and
  - (iii) Upon entry into the Registered Testing Pool all Testing Pool filing failure of the relevant Player shall be erased and do not count for the purposes of Regulation 21.2.4.
- (d) Where it is requested by the Player, such administrative review shall be conducted by a designee of World Rugby who was not involved in

the previous assessment of the alleged filing failure. The review shall be based on written submissions only, and shall consider whether all of the requirements of Regulation 21.5.6.18 are met. The review shall be completed within 14 days of receipt of the Player's request and the decision shall be communicated to the Player by letter sent no more than seven days after the decision is made;

- (e) If it appears, upon such review, that the requirements of Regulation 21.5.6.18 have not been met, then the alleged filing failure shall not be treated as a whereabouts failure for any purpose;
- (f) If the Player does not request an administrative review of the alleged filing failure by the relevant deadline, or if the administrative review leads to the conclusion that all of the requirements of Regulation 21.5.6.18 have been met, then World Rugby shall record an alleged filing failure against the Player and shall notify the Player and/or his Union and (on a confidential basis) WADA and all other relevant Anti-Doping Organisations of that alleged filing failure and the date of its occurrence.

#### **21.5.6.27 Results Management for Missed Tests**

- (a) The DCO shall file an unsuccessful Attempt report with World Rugby or its nominee (or NADO as the case may be), setting out the details of the attempted Sample collection, including the exact date and time of the attempt, the names of all the location(s) visited, the exact arrival and departure times at each of the location(s), the step(s) taken at the location(s) to try to find the Player, including details of any contact made with third parties (including their names, positions, relationship to the Player, information on the possible location of the Player if the Player is not present at the nominated residence or location and contact details), and any other relevant details about the attempted Sample collection.
- (b) If it appears that all of the Regulation 21.5.6.23 or 21.5.6.24 requirements (depending upon which testing pool the Player belongs to) relating to missed tests are satisfied, then ordinarily no later than 14 days after the date of the unsuccessful Attempt report being received by World Rugby, World Rugby must send notice to the Player via his Union of the unsuccessful attempt, inviting a response within 14 days of receipt of the notice. The unsuccessful Attempt report shall be provided to the Player at this point and World Rugby shall warn the Player:
  - (i) That unless the Player persuades World Rugby that there has not been any missed test, then (subject to the remainder of the results management process set out below) an alleged missed test will be recorded against the Player;
  - (ii) (If applicable) that there are other whereabouts failures that have been alleged against him in the 12-month period prior to this alleged whereabouts failure; and

- (iii) Of the consequences to the Player if the designee of World Rugby or a Judicial Officer or Judicial Committee in the case of a third whereabouts failure upholds the alleged missed test.
- (c) Where the Player disputes the apparent missed test, World Rugby must re-assess whether all of the requirements in Regulation 21.5.6.23 or 21.5.6.24 (depending upon which testing pool the Player belongs to) are met. World Rugby must advise the Player and/or his Union, by letter sent ordinarily no later than 14 days after receipt of the Player's response, whether or not it maintains that there has been a missed test.
- (d) If no response is received from the Player by the relevant deadline, or if World Rugby maintains (notwithstanding the Player's response) that there has been a missed test, World Rugby shall send notice to the Player and/or his Union that an alleged missed test is to be recorded against him. Further:
  - (i) In respect of Registered Testing Pool Players only, World Rugby shall at the same time advise the Player that he has the right to request an administrative review of the alleged missed test.
  - (ii) In respect of Testing Pool Players, there is no administrative review as the missed test will only count for the purposes of elevating the Player to the Registered Testing Pool.
  - (iii) Upon entry into World Rugby's Registered Testing Pool all Testing Pool missed tests cease to count for the purposes of Regulation 21.2.4.
- (e) Where the Player has recorded a missed test, World Rugby may seek to recoup from the Player and/or his Union a fee equating to the costs associated with the attempted Sample collection and the administration associated with the missed test. In the event of default or non-payment by the Player upon request, the Union of the Player shall be liable for the payment of the missed test fee.

#### **Administrative Review – Missed Test for Registered Testing Pool Players**

- (f) Where requested, such administrative review shall be conducted by a designee of World Rugby who was not involved in the previous assessment of the alleged missed test, shall be based on written submissions only, and shall consider whether all of the requirements of Regulation 21.5.6.23 are met. If necessary, the relevant DCO may be asked to provide further information to World Rugby. The review shall be completed within 14 days of receipt of the Player's request and the decision shall be communicated to the Player by letter sent no more than seven days after the decision is made.
- (g) If it appears upon such review that the requirements of Regulation 21.5.6.23 have not been met, then the unsuccessful attempt to test the Player shall not be treated as a missed test for any purpose.

- (h) If the Player does not request an administrative review of the alleged missed test by the relevant deadline, or if the administrative review leads to the conclusion that all of the requirements of Regulation 21.5.6.23 have been met, then World Rugby shall record an alleged missed test against the Player and shall notify the Player and/or his Union and (on a confidential basis) WADA and all other relevant Anti-Doping Organisations of that alleged missed test and the date of its occurrence.

#### **21.5.6.28 Confidentiality – Whereabouts Failures**

When World Rugby or its nominee, Union or NADO declares, or receives notice of, a whereabouts failure in respect of a Player it shall not disclose that information beyond those persons with a need to know unless and until that Player is found to have committed an anti-doping rule violation under Regulation 21.2.4 (Whereabouts Failures) based on (among other things) such whereabouts failure. Such persons who need to know shall also maintain the confidentiality of such information until the same point of this process.

- (a) Whereabouts information relating to a Player shall be shared (through ADAMS or other Database) with WADA and other Anti-Doping Organisations having authority to test that Player, shall be maintained in strict confidence at all times, shall be used exclusively for the purposes set out in Article 5.6 of the Code, and shall be destroyed in accordance with the International Standard for the Protection of Privacy and Personal Information once it is no longer relevant for these purposes.

#### **21.5.6.29 Judicial Proceedings**

World Rugby shall keep a record of all whereabouts failures alleged in respect to each Player within either its Registered Testing Pool or Testing Pool. Where it is alleged that such a Player has committed three whereabouts failures within any 12-month period:

- (a) Where two or more of those whereabouts failures were alleged by World Rugby, Union or NADO that had the Player in its Registered Testing Pool subject to these Regulations at the time of those failures, then that Anti-Doping Organisation (whether World Rugby, Union or NADO) shall be the Responsible Anti-Doping Organisation for the purposes of bringing proceedings against the Player under Regulation 21.2.4. If the whereabouts failures were alleged by three different Anti-Doping Organisations then the Responsible Anti-Doping Organisation for these purposes will be the Anti-Doping Organisation whose Registered Testing Pool, the Player was in as of the date of the third whereabouts failure. If the Player was in both World Rugby's Registered Testing Pool and a national Registered Testing Pool as of that date, the Responsible Anti-Doping Organisation for these purposes shall be World Rugby.

- (b) Where the Responsible Anti-Doping Organisation fails to bring proceedings against a Player under Regulation 21.2.4 (Whereabouts Failures) within 30 days of WADA receiving notice of that Player's third alleged whereabouts failure in any 12-month period, then it shall be deemed that the responsible Anti-Doping Organisation has decided that no anti-doping rule violation was committed, for the purposes of triggering the appeal rights set out at Regulation 21.13 (in particular Regulation 21.13.2).

**21.5.6.30** A Player alleged to have committed an anti-doping rule violation under Regulation 21.2.4 (Whereabouts Failures) shall have the right to have such allegation determined by a Judicial Committee in accordance with Regulation 21.8.2. The Judicial Committee shall not be bound by any determination made during the results management process, whether as to the adequacy of any explanation offered for a whereabouts failure or otherwise. Instead, the burden shall be on World Rugby to establish all of the requisite elements of each alleged whereabouts failure.

- (a) The Judicial Committee shall consider whether or not a Provisional Suspension should be imposed on the Player pending the outcome of proceedings, in accordance with Regulation 21.7.9.
- (b) If the Judicial Committee decides that one (or two) alleged whereabouts failures have been established to the required standard, but that the other alleged whereabouts failure(s) has/have not, then no anti-doping rule violation shall be found to have occurred. However, if the Player then commits one (or, as applicable, two) further whereabouts failures within the relevant 12-month period, new proceedings may be brought based on a combination of the whereabouts failure(s) established to the satisfaction of the Judicial Committee in the previous proceedings (in accordance with Regulation 21.3.24) and the whereabouts failure(s) subsequently committed by the Player.
- (c) A finding that a Player has committed an anti-doping rule violation under Regulation 21.2.4 (Whereabouts Failures) shall have the applicable consequences as outlined in Regulation 21.10.
- (d) The impact of any Regulation 21.2.4 (Whereabouts Failures) anti-doping rule violation by an individual Player on the results of any Team for which that Player has played during the relevant period shall be determined in accordance with Regulation 21.11.

## **21.5.7 Retired and Suspended Players**

**21.5.7.1** A Player in World Rugby's Registered Testing Pool who has given notice of retirement to World Rugby may not resume competing in International Events or National Events until he has given World Rugby via his Union written notice of his intent to resume competing and has made himself available for Testing for a period of six months before returning to Competition, including (if requested) complying with the whereabouts requirements of Regulation 21.5.6 and Annex I to the International



Standard for Testing and Investigations. WADA, in consultation with World Rugby and the Player's National Anti-Doping Organisation, may grant an exemption to the six-month written notice rule where the strict application of that rule would be manifestly unfair to a Player. This decision may be appealed under Regulation 21.13. Any competitive results obtained in violation of this Regulation 21.5.7.1 shall be Disqualified.

- 21.5.7.2** If a Player retires from sport while subject to a period of Ineligibility, the Player shall not resume competing in International Events or National Events until the Player has given six months' prior written notice (or notice equivalent to the period of Ineligibility remaining as of the date the Player retired, if that period was longer than six months) to World Rugby via his Union of his intent to resume competing and has made himself available for Testing for that notice period, including (if requested) complying with the whereabouts requirements of Regulation 21.5.6 and Annex I to the International Standard for Testing and Investigations.
- 21.5.7.3** A Player who is not in World Rugby's Registered Testing Pool who has given notice of retirement to World Rugby may not resume competing unless he notifies World Rugby via his Union at least six months before he wishes to return to Competition and makes himself available for unannounced Out-of-Competition Testing, including (if requested) complying with the whereabouts requirements of Regulation 21.5.6 and Annex I to the International Standard for Testing and Investigations, during the period before actual return to Competition.
- 21.5.7.4** Where a Player has been suspended, other than for life, and wishes to resume competing after his period of Ineligibility has expired, he must make himself available for Out of Competition Doping Control during that period of suspension. If a Player commits an anti-doping rule violation during the course of a suspension the matter shall be treated as a separate anti-doping rule violation.
- 21.5.7.5** A Player who has been identified by World Rugby for inclusion in the Registered Testing Pool or Testing Pool shall continue to be subject to these Anti-Doping Rules including the obligation to be available for No Advance Notice Out of Competition Testing unless and until the Player gives written notice to World Rugby via his Union that he has retired or until he no longer satisfies the criteria for inclusion in the Registered Testing Pool or Testing Pool and has been so informed by World Rugby.
- 21.5.7.6** A Player who has given notice of retirement to World Rugby from International Match level participation, but who continues to play the Game at or below National Event-level, and who elects to stay in World Rugby's Testing Pool, or be transferred to the Testing Pool from World Rugby's Registered Testing Pool, may resume competing at International Event-level upon notification to World Rugby via his Union.
- 21.5.7.7** If a Player or other Person retires while a results management process is underway, the Anti-Doping Organisation conducting the results management process retains jurisdiction to complete its results management process. If a Player or other Person retires before any results

management process has begun, the Anti-Doping Organisation which would have had results management jurisdiction over the Player or other Person at the time the Player or other Person committed an anti-doping rule violation, has jurisdiction to conduct results management. [See [Comment 21](#)]

**21.5.7.8** Unions shall establish similar requirements for retirement and returning to competition for Players in the national Registered Testing Pool and may establish similar requirements for other Players under their jurisdiction.

### **21.5.8 Independent Observer Program**

World Rugby and the organising committees for World Rugby Events, as well as the Member Unions and the organising committees for National Events, shall authorise and facilitate the Independent Observer Program at such Events.

## **21.6 ANALYSIS OF SAMPLES, RESEARCH AND INVESTIGATIONS**

Samples shall be analysed in accordance with the following principles:

### **21.6.1 Use of Accredited and Approved Laboratories**

For purposes of Regulation 21.2.1, Samples shall be analysed only in laboratories accredited or otherwise approved by WADA. The choice of the WADA-accredited or WADA-approved laboratory used for the Sample analysis shall be determined exclusively by World Rugby. [See [Comment 22](#)]

### **21.6.2 Purpose of Analysis of Samples**

**21.6.2.1** Samples shall be analysed to detect Prohibited Substances and Prohibited Methods and other substances as may be directed by WADA pursuant to the Monitoring Program described in Article 4.5 of the Code; or to assist World Rugby, Unions and Tournament Organisers in profiling relevant parameters in a Player's urine, blood or other matrix, including DNA or genomic profiling; or for any other legitimate anti-doping purpose. Samples may be collected and stored for future analysis. [See [Comment 23](#)]

**21.6.2.2** World Rugby, Unions and Tournament Organisers shall ask laboratories to analyse Samples in conformity with Article 6.4 of the Code and Article 4.7 of the International Standard for Testing and Investigations.

### **21.6.3 Research on Samples**

No Sample may be used for research without the Player's written consent. Samples used for purposes other than Regulation 21.6.2 shall have any means of identification removed such that they cannot be traced back to a particular Player.

### **21.6.4 Standards for Sample Analysis and Reporting**

Laboratories shall analyse Samples and report results in conformity with the International Standard for Laboratories. To ensure effective Testing, the

Technical Document referenced at Article 5.4.1 of the Code will establish risk assessment-based Sample analysis menus appropriate for particular sports and sport disciplines, and laboratories shall analyse Samples in conformity with those menus, except as follows:

- 21.6.4.1** World Rugby, Unions or Tournament Organisers may request that laboratories analyse its Samples using more extensive menus than those described in the Technical Document.
- 21.6.4.2** World Rugby, Unions or Tournament Organisers may request that laboratories analyse their Samples using less extensive menus than those described in the Technical Document only if World Rugby has satisfied WADA that, because of the particular circumstances of its sport, as set out in World Rugby's test distribution plan, less extensive analysis would be appropriate.
- 21.6.4.3** As provided in the International Standard for Laboratories, laboratories at their own initiative and expense may analyse Samples for Prohibited Substances or Prohibited Methods not included on the Sample analysis menu described in the Technical Document or specified by the Testing authority. Results from any such analysis shall be reported and have the same validity and consequence as any other analytical result. [See [Comment 24](#)]

#### **21.6.5 Further Analysis of Samples**

Any Sample may be stored and subsequently subjected to further analysis for the purposes set out in Regulation 21.6.2: (a) by WADA at any time; and/or (b) by World Rugby (or where the Sample was taken by a Union or Tournament Organiser, that Union or Tournament Organiser) at any time before both the A and B Sample analytical results (or A Sample result where B Sample analysis has been waived or will not be performed) have been communicated by World Rugby (or, as applicable, Union or Tournament Organiser) to the Player as the asserted basis for a Regulation 21.2.1 (Presence) anti-doping rule violation. Such further analysis of Samples shall conform with the requirements of the International Standard for Laboratories and the International Standard for Testing and Investigations.

#### **21.6.6 Investigations**

- 21.6.6.1** World Rugby or its designee may carry out investigations into the activities of any Player, Person, Union, Association, Rugby Body or Club who it has reasonable cause to believe may have committed an anti-doping rule violation. Any such Player, other Person, Union, Association, Rugby Body or Club shall co-operate with any such World Rugby investigation.
- 21.6.6.2** A Player, other Person, Union, Association, Rugby Body or Club under investigation for an alleged anti-doping rule violation by World Rugby, a Union or Tournament Organiser may be Provisionally Suspended and not allowed to participate in any aspect of the Game pending the outcome of such investigation and resolution of the case.

- 21.6.6.3** Without limiting the effect of Regulation 21.7.9, solely in circumstances where World Rugby or its designee considers that further investigation is required to determine whether an anti-doping rule violation may have been committed, the following procedures shall apply, subject to such modifications and additional procedures as World Rugby may consider necessary having regard to the facts and circumstances of the particular case and other relevant circumstances:
- (a) Any investigation shall be carried out as soon as reasonably practicable after World Rugby becomes aware of the alleged anti-doping rule violation.
  - (b) World Rugby or its designee may request that additional information be provided and may also call upon such assistance and expert and/or specialist advice including (without limitation) legal advice as it considers appropriate, whether in the form of witness testimony or otherwise.
  - (c) World Rugby or its designee shall determine whether it believes that an anti-doping rule violation may have been committed.
  - (d) Where it is decided that there are no grounds to conclude that an anti-doping violation may have been committed no further action will be taken and any Provisional Suspension shall be automatically lifted.
  - (e) As soon as it is determined that an anti-doping rule violation may have been committed, World Rugby or its designee shall notify the applicable party concerned. The applicable party shall be placed on Provisional Suspension, if he has not been already, pending resolution of the case. In addition the applicable party shall be notified that the matter shall be referred to a Judicial Committee.

## **21.7 RESULTS MANAGEMENT**

### **21.7.1 Responsibility for Conducting Results Management**

- 21.7.1.1** The circumstances in which World Rugby shall take responsibility for conducting results management in respect of anti-doping rule violations involving Players and other Persons under its jurisdiction shall be determined by reference to and in accordance with Article 7 of the Code and Regulation 21.5.3.3 and Regulation 21.7.12.

### **21.7.2 Preliminary Review of Adverse Analytical Findings From Tests Initiated by World Rugby**

Results management in respect of the results of tests initiated by World Rugby (including tests performed by WADA pursuant to agreement with World Rugby) shall proceed as follows:

- 21.7.2.1** The results from all analyses must be sent to World Rugby in encoded form, in a report signed by an authorised representative of the laboratory. All communication must be conducted confidentially and in conformity with ADAMS.

**21.7.2.2** Upon receipt of an Adverse Analytical Finding, World Rugby shall initiate a preliminary review in accordance with Regulation 21.7.2.3 to determine whether: (a) an applicable TUE has been granted or will be granted as provided in the International Standard for Therapeutic Use Exemptions, or (b) there is any apparent departure from the International Standard for Testing and Investigations or International Standard for Laboratories that caused the Adverse Analytical Finding.

**21.7.2.3** The preliminary review set out in Regulation 21.7.2.2 shall be undertaken by a representative or representatives of World Rugby's Anti-Doping Advisory Committee and/or the World Rugby Anti-Doping Judicial Panel to establish if a TUE has been granted that explains the Adverse Analytical Finding or if there is any apparent departure from the International Standard for Testing and Investigations and/or if there is any apparent departure from the International Standard for Laboratories as evidenced by the documents in respect of the particular case under consideration provided by the laboratory which undermines the validity of the Adverse Analytical Finding. Such preliminary review shall, ordinarily, be completed within three days. The representative or representatives undertaking the preliminary review may make further enquiries or investigations as it or they consider appropriate solely in relation to the existence or otherwise of a TUE or apparent departures from the International Standard for Testing and Investigations and/or the International Standard for Laboratories as evidenced by the documents in respect of the particular case under consideration provided by the laboratory. If the review does reveal an applicable TUE or departure from the International Standard for Testing and Investigations and/or applicable provisions of the International Standard for Laboratories on the foregoing basis that caused the Adverse Analytical Finding, then the entire test shall be considered negative and the Player and his Union, National Anti-Doping Organisation and WADA shall be informed.

### **21.7.3 Notification After Preliminary Review Regarding Adverse Analytical Findings**

**21.7.3.1** If the preliminary review of an Adverse Analytical Finding under Regulation 21.7.2.3 does not reveal an applicable TUE or entitlement to a TUE as provided in the International Standard for Therapeutic Use Exemptions, or departure from the International Standard for Testing and Investigations or the International Standard for Laboratories that caused the Adverse Analytical Finding, World Rugby shall promptly notify the Player, and simultaneously the Player's Union, National Anti-Doping Organisation and WADA, in the manner set out in Regulation 21.14.1, of: (a) the Adverse Analytical Finding; (b) the anti-doping rule violated; (c) the Player's right to promptly request the analysis of the B Sample or, failing such request, that the B Sample analysis may be deemed waived; (d) the scheduled date, time and place for the B Sample analysis if the Player or World Rugby chooses to request an analysis of the B Sample; (e) the opportunity for the Player and/or the Player's representative to attend the B Sample opening and analysis in accordance with the International Standard for Laboratories if such analysis is requested; and (f) the Player's right to request copies of

the A and B Sample laboratory documentation package which includes information as required by the International Standard for Laboratories. If World Rugby decides not to bring forward the Adverse Analytical Finding as an anti-doping rule violation, it shall so notify the Player, the Player's Union, National Anti-Doping Organisation and WADA.

- 21.7.3.2** Where requested by the Player or World Rugby, arrangements shall be made to analyse the B Sample in accordance with the International Standard for Laboratories. A Player may accept the A Sample analytical results by waiving the requirement for B Sample analysis. World Rugby may nonetheless elect to proceed with the B Sample analysis.
- 21.7.3.3** The Player and/or his representative shall be allowed to be present at the analysis of the B Sample. Also, a representative of World Rugby as well as a representative of the Player's Union shall be allowed to be present.
- 21.7.3.4** If the B Sample analysis does not confirm the A Sample analysis, then (unless World Rugby takes the case forward as an anti-doping rule violation under Regulation 21.2.2) the entire test shall be considered negative and the Player, the Player's Union, National Anti-Doping Organisation and WADA shall be so informed.
- 21.7.3.5** If the B Sample analysis confirms the A Sample analysis, the findings shall be reported to the Player, the Player's Union, National Anti-Doping Organisation and WADA.

#### **21.7.4 Review of Atypical Findings**

- 21.7.4.1** As provided in the International Standard for Laboratories, in some circumstances laboratories are directed to report the presence of Prohibited Substances, which may also be produced endogenously, as Atypical Findings, i.e., as findings that are subject to further investigation.
- 21.7.4.2** Upon receipt of an Atypical Finding, World Rugby shall conduct a review to determine whether: (a) an applicable TUE has been granted or will be granted as provided in the International Standard for Therapeutic Use Exemptions; (b) there is any apparent departure from the International Standard for Testing and Investigations or International Standard for Laboratories that caused the Atypical Finding; and/or (c) World Rugby is aware of any historical test data with respect to the Player which explains the Atypical Finding as arising from a permitted source.
- 21.7.4.3** If the review of an Atypical Finding under Regulation 21.7.4.2 reveals an applicable TUE and/or a departure from the International Standard for Testing and Investigations or the International Standard for Laboratories and/or historical test data that caused the Atypical Finding and/or explains the Atypical Finding as arising from a permitted source, the entire test shall be considered negative and the Player, the Player's Union, National Anti-Doping Organisation and WADA shall be so informed.
- 21.7.4.4** If that review does not reveal an applicable TUE or a departure from the International Standard for Testing and Investigations or the International Standard for Laboratories and/or historical test data that caused the

Atypical Finding and/or explains the Atypical Finding as arising from a permitted source, World Rugby shall conduct the required investigation or cause it to be conducted. This investigation may involve without limitation the requirement of the Player to undergo medical testing to ascertain the presence or otherwise of a pathological or other medical explanation for the Atypical Finding. After the investigation is completed, either the Atypical Finding will be brought forward as an Adverse Analytical Finding, in accordance with Regulation 21.7.3.1, or else the Player, the Player's Union, National Anti-Doping Organisation and WADA shall be notified that the Atypical Finding will not be brought forward as an Adverse Analytical Finding.

**21.7.4.5** World Rugby will not provide notice of an Atypical Finding until it has completed its investigation and has decided whether it will bring the Atypical Finding forward as an Adverse Analytical Finding unless one of the following circumstances exists:

21.7.4.5.1 If World Rugby determines the B Sample should be analysed prior to the conclusion of its investigation, it may conduct the B Sample analysis after notifying the Player, with such notice to include a description of the Atypical Finding and the information described in Regulation 21.7.3.1(d)-(f).

21.7.4.5.2 If World Rugby is asked (a) by a Major Event Organisation shortly before one of its International Events, or (b) by a sport organisation responsible for meeting an imminent deadline for selecting team members for an International Event, to disclose whether any Player identified on a list provided by the Major Event Organisation or sport organisation has a pending Atypical Finding, World Rugby shall so advise the Major Event Organisation or sports organisation after first providing notice of the Atypical Finding to the Player.

21.7.4.5.3 World Rugby's investigation requires the Player to undergo medical testing to ascertain the presence or otherwise of a pathological explanation for the Atypical Finding.

### **21.7.5 Review of Atypical Passport Findings and Adverse Passport Findings**

Review of Atypical Passport Findings and Adverse Passport Findings shall take place as provided in the International Standard for Testing and Investigations and International Standard for Laboratories. At such time as World Rugby is satisfied that an anti-doping rule violation has occurred, it shall promptly give the Player (and simultaneously the Player's Union, National Anti-Doping Organisation and WADA) notice of the anti-doping rule violation asserted and the basis of that assertion.

### **21.7.6 Review of Whereabouts Failures**

World Rugby shall review potential filing failures and missed tests, as defined in the International Standard for Testing and Investigations, in respect of Players who file their whereabouts information with World Rugby, in accordance with Annex I to the International Standard for Testing and Investigations. At such time as World Rugby is satisfied that a violation of

Regulation 21.2.4 (Whereabouts Failures) has occurred, it shall promptly give the Player (and simultaneously the Player's Union, National Anti-Doping Organisation and WADA) notice that it is asserting a violation of Regulation 21.2.4 (Whereabouts Failures) and the basis of that assertion.

**21.7.7 Review of Other Anti-Doping Rule Violations Not Covered by Regulations 21.7.2–21.7.6**

World Rugby shall conduct any follow-up investigation required into a possible anti-doping rule violation not covered by Regulations 21.7.2- 7.6. At such time as World Rugby is satisfied that an anti-doping rule violation has occurred, it shall promptly give the Player or other Person (and simultaneously the Player's or other Person's Union, National Anti-Doping Organisation and WADA) notice of the anti-doping rule violation asserted and the basis of that assertion.

**21.7.8 Identification of Prior Anti-Doping Rule Violations**

Before giving a Player or other Person notice of an asserted anti-doping rule violation as provided above, World Rugby shall refer to ADAMS and contact WADA and other relevant Anti-Doping Organisations to determine whether any prior anti-doping rule violation exists.

**21.7.9 Provisional Suspensions**

**21.7.9.1** When World Rugby, Union, Association or Tournament Organiser (as the case may be) receives an Adverse Analytical Finding in respect of a Player's "A" Sample or when World Rugby, Union, Association or Tournament Organiser believes or becomes aware that an anti-doping rule violation whether or not it involves the provision of a Sample, may have been committed, that Player or other Person shall, subject to Regulations 21.7.2.2 and 21.7.2.3, in the case of an "A" Sample Adverse Analytical Finding and subject to Regulation 21.16.3, in the case where there is no Sample, be Provisionally Suspended by World Rugby, Tournament Organiser, and/or his Union or Association pending the resolution of the case.

**21.7.9.2** The Player or other Person has a right to appeal the Provisional Suspension in accordance with Regulation 21.13.2 (save as set out in Regulation 21.7.9.3).

**21.7.9.3** The Provisional Suspension may be lifted if the Player demonstrates to the hearing panel that the violation is likely to have involved a Contaminated Product. A hearing panel's decision not to lift a Provisional Suspension on account of the Player's assertion regarding a Contaminated Product shall not be appealable.

**21.7.9.4** A Player or other Person subject to a Provisional Suspension shall be provided the opportunity for an expedited final hearing in accordance with Regulation 21.8 on a timely basis.

**21.7.9.5** If a Provisional Suspension is imposed based on an A Sample Adverse Analytical Finding and subsequent analysis of the B Sample does not



confirm the A Sample analysis, then the Player shall not be subject to any further Provisional Suspension on account of a violation of Regulation 21.2.1 (Presence). In circumstances where the Player (or the Player's team) has been removed from a Competition based on a violation of Regulation 21.2.1 (Presence) and the subsequent B Sample analysis does not confirm the A Sample finding, then if it is still possible for the Player or team to be reinserted, without otherwise affecting the Competition, the Player or team may continue to take part in the Competition. In addition, the Player or team may thereafter take part in other Competitions in the same Event.

**21.7.9.6** In any case where a Player or other Person has been notified of an anti-doping rule violation but a Provisional Suspension has not been imposed on him, the Player or other Person shall be offered the opportunity to accept a Provisional Suspension voluntarily pending the resolution of the matter. [See [Comment 25](#)]

#### **21.7.10 Resolution Without a Hearing**

**21.7.10.1** A Player or other Person against whom an anti-doping rule violation is asserted may admit that violation at any time, waive a hearing and/or accept the Consequences that are mandated by these Anti-Doping Rules or (where some discretion as to Consequences exists under these Anti-Doping Rules) that have been or are asserted by World Rugby. The chairman of the Judicial Panel (appointed pursuant to Regulation 18) may appoint either a legal member of the Anti-Doping Judicial Panel set out in Regulation 21.8.2 or a Judicial Committee to review the matter on the papers and impose the Consequences as appropriate. Where the Player or other Person waives his right to a hearing but wishes to make submissions in relation to sanction he shall have seven days in which to make such submissions in writing. In any case World Rugby shall be entitled to make submissions in writing to the Judicial Officer or Judicial Committee as applicable.

**21.7.10.2** If the Player or other Person against whom an anti-doping rule violation is asserted fails to dispute that assertion within 14 days of the notice sent by World Rugby, then he shall be deemed to have admitted the violation and to have waived his right to an oral hearing. In such case the Player or other Person shall have seven days in which to make submissions in writing in relation to the sanctions to be applied. In the absence of a response the chairman of the Judicial Panel (appointed pursuant to Regulation 18) may appoint either a legal member of the Anti-Doping Judicial Panel set out in Regulation 21.8.2 or a Judicial Committee to review the matter on the papers and impose the Consequences as appropriate. World Rugby shall be entitled to make submissions in writing to the Judicial Officer or Judicial Committee as applicable.

Notwithstanding the absence of a hearing, Regulation 21.8.2.7 shall apply.

#### **21.7.11 Notification of Results Management Decisions**

In all cases where World Rugby has asserted the commission of an anti-doping rule violation, withdrawn the assertion of an anti-doping rule

violation, imposed a Provisional Suspension, or proceeded with an imposition of Consequences by a Judicial Officer without an oral hearing, World Rugby shall give notice thereof in accordance with Regulation 21.14.2.1 to other Anti-Doping Organisations with a right to appeal under Regulation 21.13.2.3.

#### **21.7.12 Results Management by Unions, Associations and Tournament Organisers**

**21.7.12.1** Where an anti-doping rule violation arises out of a Doping Control conducted or arranged by a Union, Association or Tournament Organiser, or a Union, Association or Tournament Organiser believes or becomes aware that another anti-doping rule violation may have been committed by one of its members or a Player or other Person under its jurisdiction, that Union, Association or Tournament Organiser shall:

- (a) Deal with the matter in accordance with its own anti-doping procedures which shall be in compliance with these Anti-Doping Rules; and
- (b) Notify World Rugby and the Home Union of the Player or other Person concerned.

Notwithstanding the foregoing, in respect of International and Cross-Border Matches, Tours, Tournaments and Series of Matches where the Union pursuant to this Regulation does not have a WADA Code compliant National Anti-Doping Organisation in its country, World Rugby may, of its own initiative or upon request by the Union (where agreed by World Rugby), assume the conduct of all or part of the results management of such case at the cost of such Union. Nothing herein shall displace or interfere with World Rugby's rights set out in Regulation 21.

**21.7.12.2** As a minimum requirement, each Player or other Person alleged to have committed an anti-doping rule violation shall have the right to a hearing before a suitably-qualified disciplinary body established by his Union or Association before a final decision is reached unless that Player or other Person waives that right. Where the Player or other Person so waives this right he may make submissions in writing in relation to the applicable sanctions, which may be imposed in accordance with these Anti-Doping Rules. The disciplinary body shall consist of not less than three individuals, one of whom shall have knowledge of Doping Control procedures and the Code. The disciplinary body shall deal with the matter in accordance with the national law and the regulations of the Union concerned and/or the place of establishment of the Association which shall be in compliance with these Anti-Doping Rules. All decisions by the disciplinary body must be produced in writing and incorporate the reasoning behind the findings and decisions. Where World Rugby assumes the conduct of all or part of the results management pursuant to Regulation 21.7.12.1, World Rugby shall be entitled to conduct any hearing arising therefrom itself or refer the hearing to the competent anti-doping hearing body for the Union or its Association as applicable.

**21.7.12.3** Unions, Associations and/or Tournament Organisers must keep World Rugby fully apprised as to the status of pending cases and provide the results of all hearings within 72 hours of a final written decision having been made. World Rugby shall have the right to attend Union, Association and Tournament Organiser hearings as an observer and shall in the event of an appeal to CAS or reference to any other arbitral body have the right to participate, including but not limited to, making submissions, representations, adducing evidence and calling witnesses in such proceedings.

**21.7.12.4** Hearings held by Unions, Associations, Tournament Organisers and/or any other body purporting to hear cases involving anti-doping rule violations shall be completed expeditiously and in all cases within three months of the date of notification of the “A” Sample or the date of admission or the date the alleged anti-doping rule violation came to the attention of the Union, Association and/or Tournament Organiser (save were World Rugby has determined there are exceptional circumstances) or the date of completion of the results management process or other applicable investigation procedure. Hearings may be conducted on an expedited process.

### **21.7.13 National Sports Resolution Bodies**

**21.7.13.1** Where a Union elects to utilise the services of a national sports resolution body, the Union shall ensure that the following pre-conditions are complied with:

- (a) All anti-doping cases whether arising out of an Adverse Analytical Finding or otherwise shall be determined in accordance with these Anti-Doping Rules or the anti-doping rules of the Union which shall be in compliance with and reflect at national level these Anti-Doping Rules;
- (b) The first instance hearing of all anti-doping cases arising out of an Adverse Analytical Finding or otherwise shall be considered by an independent judicial panel of the Union or national sports resolution body of the country of the Union subject always to prior notification in writing to World Rugby and compliance with Regulation 21;
- (c) The jurisdiction of World Rugby and the Union to be represented and participate as a party to any Union anti-doping case (including those heard before any national sports resolution body and without limitation any referral from World Rugby (including without limitation the World Rugby Anti-Doping Advisory Committee) to an appeal committee of the national sports resolution body sitting as a post-hearing review body pursuant to Regulation 21.13.8 and 21.25), shall be specifically recognised at each stage of the Union’s anti-doping judicial process;
- (d) Where the services of a national sports resolution body are utilised by a Union (whether on appeal or in accordance with (b) above), the Union shall ensure that:

- (i) Such body shall recognise the remit of World Rugby to review every decision arising from or connected to the Game and as appropriate to accept the decision of such body and/or the Union or remit the decision to the applicable review body (including without limitation an appeal committee of the national sports resolution body sitting as a post-hearing review body) in accordance with Regulation 21.25.1; and
- (ii) Such body shall recognise the remit of World Rugby to review every appeal decision of the Union and/or the national sports resolution body acting on behalf of the Union and as appropriate to accept the appeal decision of such body and/or the Union or refer the appeal decision for consideration to CAS.

#### **21.7.14 Notification by Unions, Associations and Tournament Organisers**

**21.7.14.1** When a Union, Association or Tournament Organiser (as the case may be) receives an Adverse Analytical Finding or where a Union, Association or Tournament Organiser believes, or becomes aware, that an anti-doping rule violation may have been committed (including in cases where the Doping Control and/or results management are being handled by a NADO), that Union, Association or Tournament Organiser must notify the Anti-Doping Manager - Results and Compliance of World Rugby immediately. The Anti-Doping Manager (or his designee) shall be entitled to receive from a Union, Association or Tournament Organiser such additional information, as he may consider necessary in relation to any alleged anti-doping rule violation (including in cases where the Doping Control and/or results management are being handled by a NADO). In any event, the Anti-Doping Manager (or his designee) is entitled to receive from and shall be provided by the relevant Union, Association or Tournament Organiser with a full report of all hearings including (without limitation) the written decision of the hearing body(ies) of the relevant Union (and/or its NADO), Association or Tournament Organiser and/or national sports resolution body appointed by the Union (as the case may be) incorporating the reasoning behind the findings and decisions in respect of anti-doping rule violations as soon as practicable and in any event within 72 hours of a final written decision having been made.

**21.7.14.2** Notwithstanding the requirements of Regulation 21.7.14.1, in cases where results management is being handled by a NADO, the Union shall simultaneously when providing the initial notification in Regulation 21.7.14.1: (a) make known to World Rugby the applicable appeal provisions; (b) provide a copy of the NADO's regulations; and (c) where such regulations are not in English, provide a translation into English of the appeal provisions and, where requested, within 72 hours of such request, a translation of such other provisions as requested. In addition, the Union shall provide a full report of all hearings including (without limitation) the written decision of the hearing body(ies) of the NADO immediately following the final written decision having been made and where such decision is not in English, provide a translation within 72 hours thereof. Failure to meet the

requirements set out in Regulation 21.7.14.1 and 21.7.14.2 may render a Union liable to disciplinary proceedings.

**21.7.14.3** Subject to Regulations 21.5.3.5 and 21.5.3.6 where the conduct of a Doping Control results in an Adverse Analytical Finding or other anti-doping rule violation (involving a Player and/or other Person) or where an anti-doping rule violation arises other than through the conduct of a Doping Control in respect of a Player who is not a member of the Union that conducted or was responsible for arranging the Doping Control, then that Union or Association that had jurisdiction over the Player and/or other Person (as the case may be) at the time the test was conducted or investigation into the alleged anti-doping rule violation commenced shall report the results of such Doping Controls to the Union or Association that normally exercises jurisdiction over such Player and/or Person (as the case may be) and to World Rugby.

#### **Transfer of hearings**

**21.7.14.4** Pursuant to Regulation 21.7.14.3 above, the Player or other Person may elect to have his own Union (being the Union for which he was playing at the time the test was conducted or investigation into the alleged anti-doping rule violation commenced) or if his Union does not have its own anti-doping judicial panel, his Association where it has an anti-doping judicial panel, conduct the appropriate investigation and hearing procedures (and where an anti-doping rule violation is found to have been committed, impose the applicable sanctions) if, and only if in the case where there has been an Adverse Analytical Finding, the Player acknowledges in writing, that no issue will be taken at the hearing as to the:

- (a) Qualifications or authority of any official of any Doping Control/collection agency or WADA accredited laboratory;
- (b) Sample collection procedures;
- (c) Custody or transmission of any Sample; and
- (d) Analysis of any Sample by a WADA Accredited laboratory.

The foregoing shall be without prejudice to World Rugby's results management rights pursuant to Regulation 21.7.12.1.

**21.7.14.5** Where a Player or other Person elects to have his own Union conduct the appropriate investigation and hearing pursuant to Regulation 21.7.14.4, such election by a Player or other Person must be confirmed to his Union or Association as applicable within 14 days of being notified of the Adverse Analytical Finding and/or the alleged anti-doping violation. The Player's or other Person's own Union or Association must notify the visited Union of any such election. If a Player or other Person does not elect to have the hearing procedures carried out by his own Union or Association, then the visited Union where the Doping Control was conducted shall have jurisdiction and shall conduct the investigation and hearing procedures (and where an anti-doping rule violation is found to have been committed, impose the applicable sanctions).

## **21.8 RIGHT TO A FAIR HEARING**

### **21.8.1 Hearing Procedures**

Where the matter is referred to a Judicial Committee, save for where Regulation 21.7.10 applies, the Player or other Person concerned shall:

- (a) Be notified that the matter has been referred to a Judicial Committee;
- (b) Be provided with relevant reports and documentation in relation to the anti-doping rule violation (including the WADA accredited laboratory documentation package where requested by the Player); and
- (c) Be invited, together with any legal representative he may wish to appoint, to attend a hearing before the Judicial Committee to present relevant material and submissions.

WADA may attend the hearing as observers. In any event, World Rugby shall keep WADA fully apprised as to the status of pending cases and the result of all hearings.

The hearing before the Judicial Committee shall be held without unnecessary delay and shall be expedited where the circumstances warrant it. [See [Comment 26](#)]

### **21.8.2 Judicial Committees Dealing with Anti-Doping Rule Violations**

**21.8.2.1** World Rugby's CEO shall appoint a panel of individuals comprising specialists with knowledge of doping in sport and the Code (the "Anti-Doping Judicial Panel"). The Anti-Doping Judicial Panel shall comprise of such numbers as World Rugby's CEO shall think fit but in any event shall include the members of the Anti-Doping Advisory Committee. The chairman of the Judicial Panel (appointed pursuant to Regulation 18) or his designee, shall, appoint Judicial Committees and Post-Hearing Review Bodies from members of the Anti-Doping Judicial Panel to resolve, hear and adjudicate at first instance and on appeal in cases involving any alleged breaches of these Anti-Doping Rules.

**21.8.2.2** A Judicial Committee, appointed in accordance with Regulation 21.8.2.1, to hear cases involving anti-doping rule violations shall ordinarily comprise three members, all of whom shall be independent of World Rugby, shall have had no prior involvement with the case and shall not have the same nationality as the Player or other Person alleged to have committed an anti-doping rule violation. The appointed members shall be selected from the Anti-Doping Judicial Panel and shall comprise:

- (a) A senior legal practitioner who shall act as chairman; and
- (b) An experienced medical practitioner; and
- (c) Either a second person from category (a) or (b) above or an ex-Player or current or ex-rugby administrator.

**21.8.2.3** If one or more members of the Judicial Committee is/are unable or

unwilling, for whatever reason, to hear the case, then World Rugby may, at its absolute discretion:

- (a) Appoint a replacement(s);
- (b) Appoint a new Judicial Committee; or
- (c) Allow the remaining member(s) of the Judicial Committee to hear the case.

**21.8.2.4** Judicial Committees shall be entitled to call on experts to provide specialist advice, including legal advice.

**21.8.2.5** Judicial Committees may request that a World Rugby representative attend and present information in relation to the anti-doping rule violation.

**21.8.2.6** Subject to Regulation, 21.8.2.3, Judicial Committees shall have the power to regulate their own procedure, in each case. However, subject to this power to regulate their own procedure Judicial Committees shall conform generally with the procedural guidelines set out below:

- (a) As soon as reasonably practicable following the referral of the matter the Judicial Committee chairman, or his designee, shall notify the Player, or other Person of the date, place and time of the hearing. The Player, or other Person shall be informed that he is required to attend the hearing.
- (b) A Player, or other Person who is alleged to have committed an anti-doping rule violation shall be entitled to be represented by an official of his Union, Rugby Body/Club, or by legal counsel. Where necessary an independent interpreter shall be present at a hearing of the Judicial Committee.
- (c) In the interests of time and minimising inconvenience a Player, or other Person whose hearing is pending can be required by the Judicial Committee, prior to the hearing, to supply it with full particulars of the case that will be presented on his behalf at the hearing.
- (d) The Judicial Committee shall have the power to postpone or adjourn proceedings.
- (e) The Judicial Committee shall be entitled to receive such evidence as it thinks fit (including evidence in writing) notwithstanding that evidence may not be legally admissible, and shall be entitled to attach such weight to that evidence as it sees fit.
- (f) Generally the Judicial Committee shall apply the “best evidence rule”. This means that first-hand accounts from persons present at the hearing as to their observations/knowledge of the alleged anti-doping rule violation in question should be preferred. Hearsay evidence may be accepted. However, caution shall be exercised before hearsay evidence is accepted in preference to first-hand evidence and generally less weight is likely to be given to hearsay evidence.

Further, as a general rule, Judicial Committees should not permit the introduction of opinion evidence other than expert opinion evidence. Expert opinion evidence is only likely to be permitted when the evidence falls outside the everyday knowledge of members of the Judicial Committee.

- (g) The Judicial Committee shall be entitled to determine whether witnesses that give evidence are able to remain in the room in which the hearing is being heard after their evidence has been given.
- (h) The Judicial Committee shall endeavour to ensure that proceedings are not heard in the absence of the Player, or other Person subject to the proceedings. However, the non-attendance of a Player, or other Person or his representative, after notice of the hearing has been provided, will not prevent the Judicial Committee from proceeding with the hearing in his absence. In arriving at its decision, the Judicial Committee may, however, take into account any written statement submitted by the Player, or other Person or his representatives.
- (i) At any hearing the Judicial Committee will not be bound by judicial rules governing the procedure or the admissibility of evidence, however, the hearing shall be conducted in a fair manner with a reasonable opportunity for the Player or other Person who is alleged to have committed an anti-doping rule violation to submit evidence, address the Judicial Committee and present his case.
- (j) In respect of any hearing in relation to an anti-doping rule violation before a Judicial Committee the following will apply:
  - (i) The hearing shall be held in private;
  - (ii) Decisions may be made by majority; and
  - (iii) The Judicial Committee's deliberations on its decision shall take place in private.

**21.8.2.7** The written decision of the Judicial Committee shall be advised to all parties as soon as practicable after the conclusion of the hearing. When it considers it appropriate, the Judicial Committee may deliver a short oral decision at the conclusion of the hearing with its reasons to be put in writing and communicated to the parties at a later date, or it may reserve its decision. The decision of the Judicial Committee shall be binding upon notification to the Player, or other Person concerned and/or his Union.

**21.8.2.8** In the event that the Judicial Committee establishes that an anti-doping rule violation has been committed, the Judicial Committee shall impose sanctions on the Player, or other Person concerned in accordance with Regulation 21.10. The Judicial Committee shall also invalidate other Player awards including forfeiture of any medals and prizes.

**21.8.2.9** A Player's or other Person's costs associated with any proceedings before a Judicial Committee dealing with an anti-doping rule violation shall ordinarily be borne by the Player, or other Person, including



travel/accommodation costs of the Player or other Person, his representatives and his witnesses, as well as his legal costs.

- 21.8.2.10** A Judicial Committee dealing with an anti-doping rule violation may, in its discretion, make an award of costs against the Player, or other Person in respect of costs incurred by the Judicial Committee or other costs in relation to the investigation and/or proceedings where a sanction is imposed on the Player or other Person by the Judicial Committee.
- 21.8.2.11** Notwithstanding the provisions of Regulations 21.8.2.9 and 21.8.2.10 above, the Judicial Committee shall retain absolute discretion in relation to the awarding of costs associated with the case and may make such order as to costs as it sees fit.
- 21.8.2.12** Copies of the written decision of the Judicial Committee shall be provided to the Player or other Person and to other Anti-Doping Organisations with a right to appeal under Regulation 21.13.2.3.
- 21.8.2.13** Cases asserting anti-doping rule violations may be heard directly at CAS, with no requirement for a prior hearing, with the consent of the Athlete, World Rugby, WADA, and any other Anti-Doping Organisation that would have had a right to appeal a first instance hearing decision to CAS.
- 21.8.2.14** Where a Player or other Person is adversely affected by a decision of the Judicial Committee in relation to an anti-doping rule violation, the Player or other Person shall be advised by the Judicial Committee of his right to request a review of the decision by a Post-Hearing Review Body.
- 21.8.2.15** Any deviation or deviations from the procedures set out in this Regulation 21.8.2 shall not invalidate any finding or decision of a Judicial Committee unless it was such as to cast real doubt on the reliability of such finding or decision.
- 21.8.2.16** The minimum requirements for first instance hearings held under the jurisdiction of Unions, Tournament Organisers or NADOs in relation to alleged anti-doping rule violations are set out in Regulations 21.7.12.1 to 21.7.13. The procedural guidelines set out in Regulation 21.8.2 may also be applied to such first instance hearings.

### **21.9 AUTOMATIC DISQUALIFICATION OF INDIVIDUAL RESULTS**

An anti-doping rule violation in Individual Sports in connection with an In-Competition test automatically leads to Disqualification of the result obtained in that Competition with all resulting Consequences, including forfeiture of any medals, points and prizes. [See [Comment 27](#)]

### **21.10 SANCTIONS ON INDIVIDUALS**

#### **21.10.1 Disqualification of Results in the Event During which an Anti-Doping Rule Violation Occurs**

An anti-doping rule violation occurring during or in connection with an Event may, upon the decision of the ruling body of the Event, lead to

Disqualification of all of the Player's individual results obtained in that Event with all Consequences, including forfeiture of all medals, points and prizes, except as provided in Regulation 21.10.1.1.

Factors to be included in considering whether to Disqualify other results in an Event might include, for example, the seriousness of the Player's anti-doping rule violation and whether the Player tested negative in the other Competitions.

**21.10.1.1** If the Player establishes that he or she bears No Fault or Negligence for the violation, the Player's individual results in the other Competitions shall not be Disqualified, unless the Player's results in Competitions other than the Competition in which the anti-doping rule violation occurred were likely to have been affected by the Player's anti-doping rule violation.

**21.10.2 Ineligibility for Presence, Use or Attempted Use, or Possession of a Prohibited Substance or Prohibited Method**

The period of Ineligibility for a violation of Regulations 21.2.1 (Presence), 21.2.2 (Use or Attempted Use) or 21.2.6 (Possession) shall be as follows, subject to potential reduction or suspension pursuant to Regulations 21.10.4, 21.10.5 or 21.10.6:

**21.10.2.1** The period of Ineligibility shall be four years where:

21.10.2.1.1 The anti-doping rule violation does not involve a Specified Substance, unless the Player or other Person can establish that the anti-doping rule violation was not intentional.

21.10.2.1.2 The anti-doping rule violation involves a Specified Substance and World Rugby (or the Association, Union or Tournament Organiser handling the case as applicable) can establish that the anti-doping rule violation was intentional.

**21.10.2.2** If Regulation 21.10.2.1 does not apply, the period of Ineligibility shall be two years.

**21.10.2.3** As used in Regulations 21.10.2 and 21.10.3, the term "intentional" is meant to identify those Players who cheat. The term therefore requires that the Player or other Person engaged in conduct which he or she knew constituted an anti-doping rule violation or knew that there was a significant risk that the conduct might constitute or result in an anti-doping rule violation and manifestly disregarded that risk. An anti-doping rule violation resulting from an Adverse Analytical Finding for a substance which is only prohibited In-Competition shall be rebuttably presumed to be not intentional if the substance is a Specified Substance and the Player can establish that the Prohibited Substance was Used Out-of-Competition. An anti-doping rule violation resulting from an Adverse Analytical Finding for a substance which is only prohibited In-Competition shall not be considered intentional if the substance is not a Specified Substance and the Player can establish that the Prohibited Substance was Used Out-of-Competition in a context unrelated to sport performance.

### **21.10.3 Ineligibility for Other Anti-Doping Rule Violations**

The period of Ineligibility for anti-doping rule violations other than as provided in Regulation 21.10.2 shall be as follows, unless Regulations 21.10.5 or 21.10.6 are applicable:

- 21.10.3.1** For violations of Regulation 21.2.3 (Evading) or Regulation 21.2.5 (Tampering), the period of Ineligibility shall be four years unless, in the case of failing to submit to Sample collection, the Player can establish that the commission of the anti-doping rule violation was not intentional (as defined in Regulation 21.10.2.3), in which case the period of Ineligibility shall be two years.
- 21.10.3.2** For violations of Regulation 21.2.4, the period of Ineligibility shall be two years, subject to reduction down to a minimum of one year, depending on the Player's degree of Fault. The flexibility between two years and one year of Ineligibility in this Regulation is not available to Players where a pattern of last-minute whereabouts changes or other conduct raises a serious suspicion that the Player was trying to avoid being available for Testing.
- 21.10.3.3** For violations of Regulations 21.2.7 (Trafficking) or 21.2.8 (Administration), the period of Ineligibility shall be a minimum of four years up to lifetime Ineligibility, depending on the seriousness of the violation. A Regulation 21.2.7 (Trafficking) or 21.2.8 (Administration) violation involving a Minor shall be considered a particularly serious violation and, if committed by Player Support Personnel for violations other than for Specified Substances, shall result in lifetime Ineligibility for Player Support Personnel. In addition, significant violations of Regulations 21.2.7 (Trafficking) or 21.2.8 (Administration) which may also violate non-sporting laws and regulations, shall be reported to the competent administrative, professional or judicial authorities. [See [Comment 28](#)]
- 21.10.3.4** For violations of Regulation 21.2.9 (Complicity), the period of Ineligibility imposed shall be a minimum of two years, up to four years, depending on the seriousness of the violation.
- 21.10.3.5** For violations of Regulation 21.2.10 (Prohibited Association), the period of Ineligibility shall be two years, subject to reduction down to a minimum of one year, depending on the Player or other Person's degree of Fault and other circumstances of the case. [See [Comment 29](#)]
- 21.10.4 Elimination of the Period of Ineligibility where there is No Fault or Negligence**

If a Player or other Person establishes in an individual case that he or she bears No Fault or Negligence, then the otherwise applicable period of Ineligibility shall be eliminated. [See [Comment 30](#)]

## **21.10.5 Reduction of the Period of Ineligibility based on No Significant Fault or Negligence**

### **21.10.5.1 Reduction of Sanctions for Specified Substances or Contaminated Products for Violations of Regulations 21.2.1 (Presence), 21.2.2 (Use or Attempted Use) or 21.2.6 (Possession).**

#### **21.10.5.1.1 Specified Substances**

Where the anti-doping rule violation involves a Specified Substance, and the Player or other Person can establish No Significant Fault or Negligence, then the period of Ineligibility shall be, at a minimum, a reprimand and no period of Ineligibility, and at a maximum, two years of Ineligibility, depending on the Player's or other Person's degree of Fault.

#### **21.10.5.1.2 Contaminated Products**

In cases where the Player or other Person can establish No Significant Fault or Negligence and that the detected Prohibited Substance came from a Contaminated Product, then the period of Ineligibility shall be, at a minimum, a reprimand and no period of Ineligibility, and at a maximum, two years Ineligibility, depending on the Player's or other Person's degree of Fault. [See [Comment 31](#)]

### **21.10.5.2 Application of No Significant Fault or Negligence beyond the Application of Regulation 21.10.5.1**

If a Player or other Person establishes in an individual case where Regulation 21.10.5.1 is not applicable that he or she bears No Significant Fault or Negligence, then, subject to further reduction or elimination as provided in Regulation 21.10.6, the otherwise applicable period of Ineligibility may be reduced based on the Player or other Person's degree of Fault, but the reduced period of Ineligibility may not be less than one-half of the period of Ineligibility otherwise applicable. If the otherwise applicable period of Ineligibility is a lifetime, the reduced period under this Regulation may be no less than eight years. [See [Comment 32](#)]

## **21.10.6 Elimination, Reduction, or Suspension of Period of Ineligibility or other Consequences for Reasons Other than Fault**

### **21.10.6.1 Substantial Assistance in Discovering or Establishing Anti-Doping Rule Violations**

#### **21.10.6.1.1 World Rugby (or the Association, Union or Tournament Organiser handling the case as applicable) may, prior to a final appellate decision under Regulation 21.13 or the expiration of the time to appeal, suspend a part of the period of Ineligibility imposed in an individual case in which it has results management authority where the Player or other Person has provided Substantial Assistance to an Anti-Doping Organisation, criminal authority or professional disciplinary body which results in: (i) the Anti-Doping Organisation discovering or bringing forward an anti-doping rule violation by another Person, or (ii) which results in a criminal or disciplinary body discovering or bringing forward a criminal offense or the breach of**

professional rules committed by another Person and the information provided by the Person providing Substantial Assistance is made available to World Rugby (or the Association, Union or Tournament Organiser handling the case as applicable). After a final appellate decision under Regulation 21.13 or the expiration of time to appeal, World Rugby (or the Association, Union or Tournament Organiser handling the case as applicable) may only suspend a part of the otherwise applicable period of Ineligibility with the approval of WADA. The extent to which the otherwise applicable period of Ineligibility may be suspended shall be based on the seriousness of the anti-doping rule violation committed by the Player or other Person and the significance of the Substantial Assistance provided by the Player or other Person to the effort to eliminate doping in sport. No more than three-quarters of the otherwise applicable period of Ineligibility may be suspended. If the otherwise applicable period of Ineligibility is a lifetime, the non-suspended period under this Regulation must be no less than eight years. If the Player or other Person fails to continue to cooperate and to provide the complete and credible Substantial Assistance upon which a suspension of the period of Ineligibility was based, World Rugby (or the Association, Union or Tournament Organiser handling the case as applicable) shall reinstate the original period of Ineligibility. If World Rugby (or the Association, Union or Tournament Organiser handling the case as applicable) decides to reinstate a suspended period of Ineligibility or decides not to reinstate a suspended period of Ineligibility, that decision may be appealed by any Person entitled to appeal under Regulation 21.13.

21.10.6.1.2 To further encourage Players and other Persons to provide Substantial Assistance to Anti-Doping Organisations, at the request of World Rugby (or the Association, Union or Tournament Organiser handling the case as applicable) or at the request of the Player or other Person who has (or has been asserted to have) committed an anti-doping rule violation, WADA may agree at any stage of the results management process, including after a final appellate decision under Regulation 21.13, to what it considers to be an appropriate suspension of the otherwise-applicable period of Ineligibility and other Consequences. In exceptional circumstances, WADA may agree to suspensions of the period of Ineligibility and other Consequences for Substantial Assistance greater than those otherwise provided in this Regulation, or even no period of Ineligibility, and/or no return of prize money or payment of fines or costs. WADA's approval shall be subject to reinstatement of sanction, as otherwise provided in this Regulation. Notwithstanding Regulation 21.13, WADA's decisions in the context of this Regulation may not be appealed by any other Anti-Doping Organisation.

21.10.6.1.3 If World Rugby (or the Association, Union or Tournament Organiser handling the case as applicable) suspends any part of an otherwise applicable sanction because of Substantial Assistance, then notice providing justification for the decision shall be provided to the other Anti-Doping Organisations with a right to appeal under Regulation 21.13.2.3 as provided in Regulation 21.14.2. In unique circumstances where WADA determines that it would be in the best interest of anti-doping, WADA may authorise World Rugby (or the Association, Union or Tournament Organiser handling the case as applicable) to enter into appropriate confidentiality

agreements limiting or delaying the disclosure of the Substantial Assistance agreement or the nature of Substantial Assistance being provided. [See [Comment 33](#)]

**21.10.6.2 Admission of an Anti-Doping Rule Violation in the Absence of Other Evidence**

Where a Player or other Person voluntarily admits the commission of an anti-doping rule violation before having received notice of a Sample collection which could establish an anti-doping rule violation (or, in the case of an anti-doping rule violation other than Regulation 21.2.1, before receiving first notice of the admitted violation pursuant to Regulation 21.7) and that admission is the only reliable evidence of the violation at the time of admission, then the period of Ineligibility may be reduced, but not below one-half of the period of Ineligibility otherwise applicable.[See [Comment 34](#)]

**21.10.6.3 Prompt Admission of an Anti-Doping Rule Violation after being Confronted with a Violation Sanctionable under Regulation 21.10.2.1 or Regulation 21.10.3.1**

A Player or other Person potentially subject to a four-year sanction under Regulation 21.10.2.1 or 21.10.3.1 (for evading or refusing Sample Collection or Tampering with Sample Collection), by promptly admitting the asserted anti-doping rule violation after being confronted by World Rugby (or the Association, Union or Tournament Organiser handling the case as applicable), and also upon the approval and at the discretion of both WADA and World Rugby (or the Association, Union or Tournament Organiser handling the case as applicable), may receive a reduction in the period of Ineligibility down to a minimum of two years, depending on the seriousness of the violation and the Player or other Person's degree of Fault.

**21.10.6.4 Application of Multiple Grounds for Reduction of a Sanction**

Where a Player or other Person establishes entitlement to reduction in sanction under more than one provision of Regulation 21.10.4, 21.10.5 or 21.10.6, before applying any reduction or suspension under Regulation 21.10.6, the otherwise applicable period of Ineligibility shall be determined in accordance with Regulation 21.10.2, 21.10.3, 21.10.4, and 21.10.5. If the Player or other Person establishes entitlement to a reduction or suspension of the period of Ineligibility under Regulation 21.10.6, then the period of Ineligibility may be reduced or suspended, but not below one-fourth of the otherwise applicable period of Ineligibility.[See [Comment 35](#)]

**21.10.7 Multiple Violations**

**21.10.7.1** For a Player or other Person's second anti-doping rule violation, the period of Ineligibility shall be the greater of:

- (a) six months;
- (b) one-half of the period of Ineligibility imposed for the first anti-doping rule violation without taking into account any reduction under Regulation 21.10.6; or

- (c) twice the period of Ineligibility otherwise applicable to the second anti-doping rule violation treated as if it were a first violation, without taking into account any reduction under Regulation 21.10.6.

The period of Ineligibility established above may then be further reduced by the application of Regulation 21.10.6.

**21.10.7.2** A third anti-doping rule violation will always result in a lifetime period of Ineligibility, except if the third violation fulfils the condition for elimination or reduction of the period of Ineligibility under Regulation 21.10.4 or 21.10.5, or involves a violation of Regulation 21.2.4. In these particular cases, the period of Ineligibility shall be from eight years to lifetime Ineligibility.

**21.10.7.3** An anti-doping rule violation for which a Player or other Person has established No Fault or Negligence shall not be considered a violation for purposes of this Regulation.

**21.10.7.4** Additional Rules for Certain Potential Multiple Violations

21.10.7.4.1 For purposes of imposing sanctions under Regulation 21.10.7, an anti-doping rule violation will only be considered a second violation if World Rugby (or the Association, Union or Tournament Organiser handling the case as applicable) can establish that the Player or other Person committed the second anti-doping rule violation after the Player or other Person received notice pursuant to Regulation 21.7, or after World Rugby (or the Association, Union or Tournament Organiser handling the case as applicable) made reasonable efforts to give notice of the first anti-doping rule violation. If World Rugby (or the Association, Union or Tournament Organiser handling the case as applicable) cannot establish this, the violations shall be considered together as one single first violation, and the sanction imposed shall be based on the violation that carries the more severe sanction.

21.10.7.4.2 If, after the imposition of a sanction for a first anti-doping rule violation, World Rugby (or the Association, Union or Tournament Organiser handling the case as applicable) discovers facts involving an anti-doping rule violation by the Player or other Person which occurred prior to notification regarding the first violation, then World Rugby (or the Association, Union or Tournament Organiser handling the case as applicable) shall impose an additional sanction based on the sanction that could have been imposed if the two violations had been adjudicated at the same time. Results in all Competitions dating back to the earlier anti-doping rule violation will be Disqualified as provided in Regulation 21.10.8.

**21.10.7.5** Multiple Anti-Doping Rule Violations during Ten-Year Period

For purposes of Regulation 21.10.7, each anti-doping rule violation must take place within the same ten-year period in order to be considered multiple violations.

#### **21.10.8 Disqualification of Results in Competitions Subsequent to Sample Collection or Commission of an Anti-Doping Rule Violation**

In addition to the automatic Disqualification of the results in the Competition which produced the positive Sample under Regulation 21.9, all other competitive results of the Player obtained from the date a positive Sample was collected (whether In-Competition or Out-of-Competition), or other anti-doping rule violation occurred, through the commencement of any Provisional Suspension or Ineligibility period, shall, unless fairness requires otherwise, be Disqualified with all of the resulting Consequences including forfeiture of any medals, points and prizes. [See [Comment 36](#)]

#### **21.10.9 Allocation of CAS Cost Awards and Forfeited Prize Money**

The priority for repayment of CAS cost awards and forfeited prize money shall be: first, payment of costs awarded by CAS; and second, reimbursement of the expenses of World Rugby.

#### **21.10.10 Financial Consequences**

Where a Player or other Person commits an anti-doping rule violation, World Rugby (or the Association, Union or Tournament Organiser handling the case as applicable) may, in its discretion and subject to the principle of proportionality, elect to recover from the Player or other Person costs associated with the anti-doping rule violation, regardless of the period of Ineligibility imposed.

The recovery of costs shall not be considered a basis for reducing the Ineligibility or other sanction which would otherwise be applicable under these Anti-Doping Rules or the Code.

#### **21.10.11 Commencement of Ineligibility Period**

Except as provided below, the period of Ineligibility shall start on the date of the final hearing decision providing for Ineligibility or, if the hearing is waived or there is no hearing, on the date Ineligibility is accepted or otherwise imposed.

##### **21.10.11.1 Delays Not Attributable to the Player or other Person**

Where there have been substantial delays in the hearing process or other aspects of Doping Control not attributable to the Player or other Person, World Rugby (or the Association, Union or Tournament Organiser handling the case as applicable) may start the period of Ineligibility at an earlier date commencing as early as the date of Sample collection or the date on which another anti-doping rule violation last occurred. All competitive results achieved during the period of Ineligibility, including retroactive Ineligibility, shall be Disqualified. [See [Comment 37](#)]

##### **21.10.11.2 Timely Admission**

Where the Player or other Person promptly (which, in all events, for a Player means before the Player competes again) admits the anti-doping rule



violation after being confronted with the anti-doping rule violation by World Rugby (or the Association, Union or Tournament Organiser handling the case as applicable), the period of Ineligibility may start as early as the date of Sample collection or the date on which another anti-doping rule violation last occurred. In each case, however, where this Regulation is applied, the Player or other Person shall serve at least one-half of the period of Ineligibility going forward from the date the Player or other Person accepted the imposition of a sanction, the date of a hearing decision imposing a sanction, or the date the sanction is otherwise imposed. This Regulation shall not apply where the period of Ineligibility has already been reduced under Regulation 21.10.6.3.

### **21.10.11.3 Credit for Provisional Suspension or Period of Ineligibility Served**

21.10.11.3.1 If a Provisional Suspension is imposed and respected by the Player or other Person, then the Player or other Person shall receive a credit for such period of Provisional Suspension against any period of Ineligibility which may ultimately be imposed. If a period of Ineligibility is served pursuant to a decision that is subsequently appealed, then the Player or other Person shall receive a credit for such period of Ineligibility served against any period of Ineligibility which may ultimately be imposed on appeal.

21.10.11.3.2 If a Player or other Person voluntarily accepts a Provisional Suspension in writing from World Rugby (or the Association, Union or Tournament Organiser handling the case as applicable) and thereafter respects the Provisional Suspension, the Player or other Person shall receive a credit for such period of voluntary Provisional Suspension against any period of Ineligibility which may ultimately be imposed. A copy of the Player or other Person's voluntary acceptance of a Provisional Suspension shall be provided promptly to each party entitled to receive notice of an asserted anti-doping rule violation under Regulation 21.14.1. [See [Comment 38](#)]

21.10.11.3.3 No credit against a period of Ineligibility shall be given for any time period before the effective date of the Provisional Suspension or voluntary Provisional Suspension regardless of whether the Player elected not to compete or was suspended by his or her team.

21.10.11.3.4 In Team Sports, where a period of Ineligibility is imposed upon a team, unless fairness requires otherwise, the period of Ineligibility shall start on the date of the final hearing decision providing for Ineligibility or, if the hearing is waived, on the date Ineligibility is accepted or otherwise imposed. Any period of team Provisional Suspension (whether imposed or voluntarily accepted) shall be credited against the total period of Ineligibility to be served. [See [Comment 39](#)]

### **21.10.12 Status During Ineligibility**

#### **21.10.12.1 Prohibition Against Participation During Ineligibility**

No Player or other Person who has been declared Ineligible may, during the period of Ineligibility, participate in any capacity in a Competition or activity (other than authorized anti-doping education or rehabilitation

programmes) authorised or organised by World Rugby or any Member Union, Association or a Club, Rugby Body or other member organisation of World Rugby or any Association or Member Union, or in Competitions authorised or organised by any professional league or any international- or national-level Event organisation or any elite or national-level sporting activity funded by a governmental agency.

A Player or other Person subject to a period of Ineligibility longer than four years may, after completing four years of the period of Ineligibility, participate as a Player in local sport events not sanctioned or otherwise under the jurisdiction of a Code Signatory or member of a Code Signatory, but only so long as the local sport event is not at a level that could otherwise qualify such Player or other Person directly or indirectly to compete in (or accumulate points toward) a national championship or International Event, and does not involve the Player or other Person working in any capacity with Minors.

A Player or other Person subject to a period of Ineligibility shall remain subject to Testing. [See [Comment 40](#)]

#### **21.10.12.2 Return to Training**

As an exception to Regulation 21.10.12.1, a Player may return to train with a team or to use the facilities of a Union, Club, Rugby Body or other member organisation of World Rugby, an Association or a Union during the shorter of: (1) the last two months of the Player's period of Ineligibility, or (2) the last one-quarter of the period of Ineligibility imposed. [See [Comment 41](#)]

#### **21.10.12.3 Violation of the Prohibition of Participation During Ineligibility**

Where a Player or other Person who has been declared Ineligible violates the prohibition against participation during Ineligibility described in Regulation 21.10.12.1, the results of such participation shall be Disqualified and a new period of Ineligibility equal in length up to the original period of Ineligibility shall be added to the end of the original period of Ineligibility. The new period of Ineligibility may be adjusted based on the Player or other Person's degree of Fault and other circumstances of the case. The determination of whether a Player or other Person has violated the prohibition against participation, and whether an adjustment is appropriate, shall be made by World Rugby (or the Association, Union or Tournament Organiser handling the case as applicable). This decision may be appealed under Regulation 21.13.

Where a Player Support Person or other Person assists a Person in violating the prohibition against participation during Ineligibility, World Rugby (or the Association, Union or Tournament Organiser handling the case as applicable) shall impose sanctions for a violation of Regulation 21.2.9 (Complicity) for such assistance.

#### **21.10.12.4 Withholding of Financial Support during Ineligibility**

In addition, for any anti-doping rule violation not involving a reduced sanction as described in Regulation 21.10.4 or Regulation 21.10.5, some or all sport-related financial support or other sport-related benefits received by such

Person will be withheld by World Rugby and its Associations and Member Unions.

### **21.10.13 Automatic Publication of Sanction**

A mandatory part of each sanction shall include automatic publication, as provided in Regulation 21.14.3. [See [Comment 42](#)]

## **21.11 CONSEQUENCES TO TEAMS**

### **21.11.1 Testing of Team Sports**

Where more than one Member of a Team in a Team Sport has been notified of an anti-doping rule violation under Regulation 21.7 in connection with an Event, the ruling body for the Event shall conduct appropriate Target Testing of the team during the Event Period.

### **21.11.2 Consequences for Team Sports**

If more than two Members of a Team in a Team Sport are found to have committed an anti-doping rule violation during an Event Period, the ruling body of the Event shall impose an appropriate sanction on the team (e.g., loss of points, Disqualification from a Competition or Event, or other sanction) in addition to any Consequences imposed upon the individual Players committing the anti-doping rule violation.

### **21.11.3 Event Ruling Body May Establish Stricter Consequences for Team Sports**

The ruling body for an Event may elect to establish rules for the Event which impose Consequences for Team Sports stricter than those in Regulation 21.11.2 for purposes of the Event. [See [Comment 43](#)]

## **21.12 SANCTIONS AND COSTS ASSESSED AGAINST SPORTING BODIES**

**21.12.1** World Rugby has the authority to withhold some or all funding or other non-financial support to Member Unions which are not in compliance with these Anti-Doping Rules and/or in order to meet the amounts of any fine pursuant to Regulation 21.12.2 which have not been paid by the Member Union within the time period stipulated by World Rugby and/or Judicial Officer or Judicial Committee, as applicable. Similarly, World Rugby may withhold from the Member Union any amount not paid by the Player or other Person pursuant to Regulation 21.10.10 and the Member Union may seek this amount in turn from the Player or other Person under its direct jurisdiction.

**21.12.2** Where a Member Union fails to make diligent efforts to keep World Rugby informed about a Player's whereabouts after receiving a request for that information from World Rugby and/or fails to submit Therapeutic Use Exemption requests at least 30 days, or such other time as stipulated by World Rugby, in advance of a competition without reasonable excuse, World Rugby may impose a fine administratively upon the Member Union in an amount up to £500 pounds sterling per Player in addition to all of World Rugby's costs incurred in Testing that Member Union's Players.

Notwithstanding the foregoing, in the event that the failures by the Member Union are such that World Rugby seeks to impose a fine in an amount above £500 pounds sterling per Player pursuant to this Regulation 21.12.2 it may do so pursuant to an order of a Judicial Officer or Judicial Committee following disciplinary action against the Member Union under Regulation 18.

- 21.12.3** Notwithstanding Regulations 21.12.1 and 21.12.2 above, World Rugby may instigate an investigation into the compliance of any Member Union with these Anti-Doping Rules which the Member Union shall facilitate. As a result of such investigation World Rugby may direct a Member Union to take certain action to bring itself into compliance with these Anti-Doping Rules. A failure by a Member Union to comply with such direction(s) within the stipulated period may give rise to disciplinary action which shall be dealt with pursuant to Regulation 18.

## **21.13 APPEALS AND POST-HEARING REVIEWS**

### **21.13.1 Decisions Subject to Appeal**

Decisions made under these Anti-Doping Rules may be appealed as set forth below in Regulation 21.13.2 through Regulation 21.13.7 or as otherwise provided in these Anti-Doping Rules, the Code or the International Standards. Such decisions shall remain in effect while under appeal unless the appellate body orders otherwise. Before an appeal is commenced, the post-decision review procedure provided in Regulation 21.13.8 must be exhausted, provided that such review respects the principles set forth in Regulation 21.13.2.2 below (except as provided in Regulation 21.13.1.3).

#### **21.13.1.1 Scope of Review Not Limited**

The scope of review on appeal includes all issues relevant to the matter and is expressly not limited to the issues or scope of review before the initial decision maker.

#### **21.13.1.2 CAS Shall Not Defer to the Findings Being Appealed**

In making its decision, CAS need not give deference to the discretion exercised by the body whose decision is being appealed. [See [Comment 44](#)]

#### **21.13.1.3 WADA Not Required to Exhaust Internal Remedies**

Where WADA has a right to appeal under Regulation 21.13 and no other party has appealed a final decision within World Rugby's process, WADA may appeal such decision directly to CAS without having to exhaust other remedies in World Rugby's process. [See [Comment 45](#)]

### **21.13.2 Appeals from Decisions Regarding Anti-Doping Rule Violations, Consequences, Provisional Suspensions, Recognition of Decisions and Jurisdiction**

A decision that an anti-doping rule violation was committed, a decision imposing Consequences or not imposing Consequences for an anti-doping rule violation, or a decision that no anti-doping rule violation was committed; a decision that an anti-doping rule violation proceeding cannot go forward for procedural reasons (including, for example, prescription); a decision by WADA not to grant an exception to the six months' notice requirement for a retired Player to return to Competition under Regulation 21.5.7.1; a decision by WADA assigning results management under Regulation 21.7.1 of the Code; a decision by World Rugby not to bring forward an Adverse Analytical Finding or an Atypical Finding as an anti-doping rule violation, or a decision not to go forward with an anti-doping rule violation after an investigation under Regulation 21.7.7; a decision to impose a Provisional Suspension as a result of a Provisional Hearing; a failure by World Rugby, Union, Association or Tournament Organiser to comply with Regulation 21.7.9; a decision that World Rugby, Union, Association or Tournament Organiser lacks jurisdiction to rule on an alleged anti-doping rule violation or its Consequences; a decision to suspend, or not suspend, a period of Ineligibility or to reinstate, or not reinstate, a suspended period of Ineligibility under Regulation 21.10.6.1; a decision under Regulation 21.10.12.3; and a decision by World Rugby, a Union, Association or Tournament Organiser not to recognise another Anti-Doping Organisation's decision under Regulation 21.15, may be appealed exclusively as provided in Regulations 21.13.2 to 21.13.7.

#### **21.13.2.1 Appeals Involving International-Level Players or International Events**

In cases arising from participation in an International Event or in cases involving International-Level Players, the decision may be appealed exclusively to CAS. [See [Comment 46](#)]

#### **21.13.2.2 Appeals Involving Other Players or Other Persons**

In cases where Regulation 21.13.2.1 is not applicable, the decision may be appealed to a national-level appeal body (and/or Association-level appeal body where the Association's appeal body acts as the national appeal-body for the relevant Union), being an independent and impartial body established in accordance with rules adopted by the National Anti-Doping Organisation, Union and/or Association, as applicable, having jurisdiction over the Player or other Person. The rules for such appeal shall respect the following principles: a timely hearing; a fair and impartial hearing panel; the right to be represented by counsel at the Person's own expense; and a timely, written, reasoned decision. If the National Anti-Doping Organisation, Union and/or Association has not established such a body, the decision may be appealed to CAS in accordance with the provisions applicable before such court.

#### **21.13.2.3 Persons Entitled to Appeal**

In cases under Regulation 21.13.2.1, the following parties shall have the right to appeal to CAS: (a) the Player or other Person who is the subject of the decision being appealed; (b) the other party to the case in which the decision was rendered; (c) World Rugby; (d) the National Anti-Doping

Organisation of the Person's country of residence or countries where the Person is a national or registered with the Union; (e) the International Olympic Committee or International Paralympic Committee, as applicable, where the decision may have an effect in relation to the Olympic Games or Paralympic Games, including decisions affecting eligibility for the Olympic Games or Paralympic Games; and (f) WADA.

In cases under Regulation 21.13.2.2, the parties having the right to appeal to the national-level appeal body shall be as provided in the National Anti-Doping Organisation's or other applicable rules but, at a minimum, shall include the following parties: (a) the Player or other Person who is the subject of the decision being appealed; (b) the other party to the case in which the decision was rendered; (c) World Rugby; (d) the National Anti-Doping Organisation of the Person's country of residence; (e) the International Olympic Committee or International Paralympic Committee, as applicable, where the decision may have an effect in relation to the Olympic Games or Paralympic Games, including decisions affecting eligibility for the Olympic Games or Paralympic Games; and (f) WADA. For cases under Regulation 21.13.2.2, WADA, the International Olympic Committee, the International Paralympic Committee, and World Rugby shall also have the right to appeal to CAS with respect to the decision of the national-level appeal body. Any party filing an appeal shall be entitled to assistance from CAS to obtain all relevant information from the Anti-Doping Organisation whose decision is being appealed and the information shall be provided if CAS so directs.

Notwithstanding any other provision herein, the only Person who may appeal from a Provisional Suspension is the Player or other Person upon whom the Provisional Suspension is imposed.

#### **21.13.2.4 Cross Appeals and other Subsequent Appeals Allowed**

Cross appeals and other subsequent appeals by any respondent named in cases brought to CAS under the Code are specifically permitted. Any party with a right to appeal under this Regulation 21.13 must file a cross appeal or subsequent appeal at the latest with the party's answer. [See [Comment 47](#)]

#### **21.13.3 Failure to Render a Timely Decision**

**21.13.3.1** Where, in a particular case, World Rugby fails to render a decision with respect to whether an anti-doping rule violation was committed within a reasonable deadline set by WADA, WADA may elect to appeal directly to CAS as if World Rugby had rendered a decision finding no anti-doping rule violation. If the CAS hearing panel determines that an anti-doping rule violation was committed and that WADA acted reasonably in electing to appeal directly to CAS, then WADA's costs and attorney fees in prosecuting the appeal shall be reimbursed to WADA by World Rugby. [See [Comment 48](#)]

**21.13.3.2** Where, in a particular case, a Member Union, Association or Tournament Organiser fails to render a decision with respect to whether an anti-doping rule violation was committed within three months (save where World Rugby

has determined there are exceptional circumstances), World Rugby may elect to bring the case directly before a World Rugby Judicial Committee at the expense of the Union, Association or Tournament Organiser concerned. As a minimum requirement decisions by Unions, Associations or Tournament Organisers in relation to anti-doping rule violations shall be subject to a post-hearing review process substantially in compliance with the process set out in Regulation 21.13.8. Thereafter the appeal procedures set out in Regulations 21.13.1 to 21.13.7 may be applied.

#### **21.13.4 Appeals Relating to TUEs**

TUE decisions may be appealed exclusively as provided in Regulation 21.4.4 and 21.4.7.

#### **21.13.5 Notification of Appeal Decisions**

Any Anti-Doping Organisation that is a party to an appeal shall promptly provide the appeal decision to the Player or other Person and to the other Anti-Doping Organisations that would have been entitled to appeal under Regulation 21.13.2.3 as provided under Regulation 21.14.2.

#### **21.13.6 Appeal from Decisions Pursuant to Regulation 21.12**

Decisions by World Rugby pursuant to Regulation 21.12 may be appealed exclusively to CAS by the Member Union (subject to submission of the matter to the post-hearing review procedures set out in Regulation 21.13.8).

#### **21.13.7 Time for Filing Appeals**

##### **21.13.7.1 Appeals to CAS**

The time to file an appeal to CAS shall be twenty-one days from the date of receipt of the decision by the appealing party. Save for in the case of an appeal directly to CAS by WADA from a first-instance decision or an appeal by any party from a National Anti-Doping Organisation first-instance decision where there is no appeal body, the decision for this purpose shall refer, in the case of any appeal pursuant to Regulation 21.13.2.1, to the decision of the post-hearing review body pursuant to Regulation 21.13.8, and in the case of an appeal to CAS from a decision issued under Regulation 21.13.2.2, to the decision of the national or Association-level appeal body as applicable, in accordance with Regulation 21.13.1. The above notwithstanding, the following shall apply in connection with appeals filed by a party entitled to appeal but which was not a party to the proceedings that led to the decision being appealed:

- (a) Within fifteen days from notice of the decision, such party/ies shall have the right to request a copy of the case file from the body that issued the decision;
- (b) If such a request is made within the fifteen-day period, then the party making such request shall have twenty-one days from receipt of the file to file an appeal to CAS.

The above notwithstanding, the filing deadline for an appeal filed by WADA shall be the later of:

- (a) Twenty-one days after the last day on which any other party in the case could have appealed; or
- (b) Twenty-one days after WADA's receipt of the complete file relating to the decision.

#### **21.13.7.2 Appeals Under Regulation 21.13.2.2**

The time to file an appeal to an independent and impartial body established at national (or Association) level shall be as set out in the anti-doping rules of the Union, Association or National Anti-Doping Organisation as applicable.

The above notwithstanding, the filing deadline for an appeal or intervention filed by WADA shall be the later of:

- (a) Twenty-one days after the last day on which any other party in the case could have appealed, or
- (b) Twenty-one days after WADA's receipt of the complete file relating to the decision.

#### **21.13.8 Post-Hearing Review Procedure**

##### **Referrals to the World Rugby Post-Hearing Review Body**

**21.13.8.1** A Player or other Person who has been found by a Judicial Committee to have committed an anti-doping rule violation shall be entitled to have the finding and/or sanction referred to the Post-Hearing Review Body. In circumstances where the Player has been subject to a period of Ineligibility then pending the decision of the Post-Hearing Review Body, the Player or other Person shall not be entitled to participate in the Game or in any activities, such participation includes but is not limited to coaching, officiating, selection, Team management, administration or promotion of the Game, playing, training as part of a Team or squad, or involvement in the Game in any other capacity in any Union. World Rugby shall also be entitled to refer a case dealt with by a Judicial Committee to the Post-Hearing Review Body whether the Player or other Person in the case concerned has been found to have committed an anti-doping rule violation or otherwise.

**21.13.8.2** Subject to Regulation 21.25.1 in the case of World Rugby, a referral to the Post-Hearing Review Body must be made within seven days from the date of notification of the decision of the Judicial Committee. A notice of review from the party seeking review must be lodged with the Anti-Doping Manager within seven days from the date of notification to the Player or other Person of the decision of the Judicial Committee and shall specify:

- (a) The name of the party seeking the review;
- (b) The decision to be the subject of the review;



- (c) The date of the decision; and
- (d) The specific grounds for the referral request. Except as provided, no specific form of a notice of review is required.

**21.13.8.3** The Post-Hearing Review Body shall be made up of three members all of whom shall have knowledge of doping in sport and the Code, and shall ordinarily comprise:

- (a) A senior legal practitioner who shall act as chairman;
- (b) An experienced medical practitioner; and
- (c) Either a second person from category (a) or (b) above or an ex-Player or rugby administrator.

**21.13.8.4** If one or more members of the Post-Hearing Review Body is/are unable or unwilling, for whatever reason, to conduct the review, then World Rugby may in its absolute discretion:

- (a) Appoint a replacement(s);
- (b) Appoint a new Post-Hearing Review Body; or
- (c) Allow the remaining member(s) of the Post-Hearing Review Body to conduct the review.

**21.13.8.5** The Post-Hearing Review Body shall determine the basis upon which any review will proceed. It may, however, in its discretion rehear the whole or any part of the evidence given before the Judicial Committee as it considers appropriate. Pending the decision of the Post-Hearing Review Body the decision of the Judicial Committee remains in full force and effect.

**21.13.8.6** Where any question of fact arises on any review before the Post-Hearing Review Body it may be determined by reference to the record of proceedings before the Judicial Committee. However, the Post-Hearing Review Body, in its discretion, may rehear or receive written evidence in respect of the whole or any part of the evidence given before the Judicial Committee as it considers appropriate.

**21.13.8.7** The Post-Hearing Review Body shall have the power to conduct and regulate the review proceedings as it sees fit having regard to the circumstances of the case. Although the Post-Hearing Review Body is entitled to regulate its own procedure it shall conform to the procedures stated in these Anti-Doping Rules and with the procedural guidelines set out below:

- (a) The review shall be conducted in a timely fashion;
- (b) The parties shall have the right to be represented by counsel at their own expense; and
- (c) The decision shall be timely, written and reasoned.

- 21.13.8.8** The Post-Hearing Review Body shall be entitled to call on experts to provide specialist advice, including legal advice.
- 21.13.8.9** The Post-Hearing Review Body shall have full discretionary power to hear and receive such further evidence as it thinks fit, provided it is established by the party wishing to lead such new evidence that such evidence was not, on reasonable enquiry, available at the time of the original hearing.
- 21.13.8.10** In any case where a witness required by the Post-Hearing Review Body refuses or fails to attend before the Post-Hearing Review Body, the Post-Hearing Review Body may decide whether or not to allow the evidence of that witness to be given in any other form.
- 21.13.8.11** Save where the Post-Hearing Review Body decides to hear the entire case de novo (in which circumstances the applicable first instance standards and burdens shall apply), the party seeking review shall have the burden of proving that the decision being challenged should be overturned or varied.
- 21.13.8.12** The Post-Hearing Review Body may request that a World Rugby representative attend the hearing before the Post-Hearing Review Body.
- 21.13.8.13** The decision of the Post-Hearing Review Body shall be advised to the parties as soon as practicable after the conclusion of the hearing and WADA. When it considers it appropriate, the Post-Hearing Review Body may deliver a short oral decision at the conclusion of the hearing with its reasons to be put in writing and communicated to the parties at a later date, or it may reserve its decision.
- 21.13.8.14** Costs associated with any proceedings before the Post-Hearing Review Body shall, ordinarily, be borne by the party seeking review. The Post-Hearing Review Body shall, however, have full discretion in relation to the costs of Post-Hearing Review Body proceedings and may order any party or parties to pay some or all of the costs of proceedings under this Regulation 21.13.8 including the cost of holding the review, the cost of any interpreters and/or the legal and/or travel/accommodation costs of the members of the Post-Hearing Review Body and/or the parties.
- 21.13.8.15** In exercising its jurisdiction the Post-Hearing Review Body shall have power to quash, suspend, vary or increase the decisions and/or sanction reviewed, subject always to the provisions of Regulation 21.10.

#### **Union, Association and Tournament Organiser Post-Hearing Review Procedures**

- 21.13.8.16** In respect of cases involving anti-doping rule violations under the jurisdiction of Unions, Associations or Tournament Organisers following a first instance hearing and/or decision, Unions, Associations and/or Tournament Organisers as applicable shall establish an independent post-hearing review body (which for the avoidance of doubt may, without limitation, be the appeal committee of the national sports resolution body) and shall implement procedures in compliance with Regulation 21.13.8.1 to 21.13.8.15 above and Regulation 21.25.1 below.

**21.13.8.17** Unions, Associations and Tournament Organisers must ensure that as a minimum requirement the parties having the right to refer a case to the post-hearing review body of the Union, Association or Tournament Organiser (as the case may be) shall include the Player or other Person subject to the decision being reviewed, the Union, Association or Tournament Organiser (as the case may be), World Rugby (including without limitation representative(s) of its Anti-Doping Advisory Committee pursuant to Regulation 21.25.1) and WADA. The written decision of the post-hearing review body shall be notified to World Rugby within 72 hours of it being communicated to the Player or other Person concerned.

## **21.14 CONFIDENTIALITY AND REPORTING**

### **21.14.1 Information Concerning Adverse Analytical Findings, Atypical Findings, and Other Asserted Anti-Doping Rule Violations**

#### **21.14.1.1 Notice of Anti-Doping Rule Violations to Players and other Persons**

Notice to Players or other Persons of anti-doping rule violations asserted against them shall occur as provided under Regulations 21.7 and 21.14 of these Anti-Doping Rules. Notice to a Player or other Person may be accomplished by delivery of the notice to his Union.

#### **21.14.1.2 Notice of Anti-Doping Rule Violations to Unions and National Anti-Doping Organisations and WADA**

Notice of the assertion of an anti-doping rule violation to National Anti-Doping Organisations and WADA shall occur as provided under Regulations 21.7 and 21.14 of these Anti-Doping Rules, simultaneously with the notice to the Player or other Person.

#### **21.14.1.3 Content of an Anti-Doping Rule Violation Notice**

Notification of an anti-doping rule violation under Regulation 21.2.1 (Presence) shall include: the Player's name, country, discipline (e.g. fifteen-a-side, seven-a-side or other form of the Game and/or age-grade), the Player's competitive level, whether the test was In-Competition or Out-of-Competition, the date of Sample collection, the analytical result reported by the laboratory, and other information as required by the International Standard for Testing and Investigations.

Notice of anti-doping rule violations other than under Regulation 21.2.1 (Presence) shall include the rule violated and the basis of the asserted violation.

#### **21.14.1.4 Status Reports**

Except with respect to investigations which have not resulted in notice of an anti-doping rule violation pursuant to Regulation 21.14.1.1, National Anti-Doping Organisations and WADA shall be regularly updated on the status and findings of any review or proceedings conducted pursuant to Regulations 21.7, 21.8 or 21.13 and shall be provided with a prompt written reasoned explanation or decision explaining the resolution of the matter.

## **21.14.2 Notice of Anti-Doping Rule Violation Decisions and Request for Files**

**21.14.2.1** Anti-doping rule violation decisions rendered pursuant to Regulation 21.7.11, 21.8.2, 21.10.4, 21.10.5, 21.10.6, 21.10.12.3 or 21.13.5 shall include the full reasons for the decision, including, if applicable, a justification for why the greatest possible Consequences were not imposed. Where the decision is not in English, the Union, Association or Tournament Organiser shall provide a short English summary of the decision and the supporting reasons and/or a full translation as requested by World Rugby.

**21.14.2.2** An Anti-Doping Organisation having a right to appeal a decision received pursuant to Regulation 21.14.2.1 may, within fifteen days of receipt, request a copy of the full case file pertaining to the decision.

## **21.14.3 Public Disclosure**

**21.14.3.1** Where an anti-doping rule violation may have been committed, World Rugby, Union, Association and/or Tournament Organiser concerned shall take reasonable steps to maintain confidentiality of the Player(s) or other Person(s) involved until the testing and analysis has been completed, the Judicial Committee hearing decision has been reached and the Player, or Person and his Union have been informed. Where the circumstances warrant it, the identity of the Player or other Person(s) who is formally alleged to have committed the anti-doping rule violation, may be publicly disclosed by his Union (after reasonable notice to the Player and/or Person, his NADO, World Rugby and WADA in accordance with, and subject to compliance with, Regulations 21.7.3, 21.7.4, 21.7.5, 21.7.6 or 21.7.7 as applicable save in cases of emergency media situations, public speculation and/or other exceptional and/or unusual cases) if non-disclosure could potentially damage the reputation of the Player or Person's Union or Player or Person's team always having due regard to the Player or Person's own reputation.

**21.14.3.2** No later than twenty days after it has been determined in a final appellate decision under Regulation 21.13.2.1 or 21.13.2.2, or such appeal has been waived, or a hearing in accordance with Regulation 21.8 has been waived, or the assertion of an anti-doping rule violation has not been timely challenged, World Rugby, the Union, Association or Tournament Organiser as applicable must Publicly Report the disposition of the matter, including without limitation the anti-doping rule violated, the name of the Player or other Person committing the violation, the name of his Union, the Prohibited Substance or Prohibited Method involved (if any), and the Consequences imposed. World Rugby, the Union, Association or Tournament Organiser must also Publicly Report within twenty days the results of final appeal decision and post-hearing review decision (where it is not appealed) concerning anti-doping rule violations, including the information described above.

**21.14.3.3** In any case where it is determined, after a hearing or appeal, that the Player or other Person did not commit an anti-doping rule violation, the decision may be Publicly Disclosed only with the consent of the Player or other Person who is the subject of the decision save where it is published in an

anonymised form. World Rugby, the Union, Association or Tournament Organiser shall use reasonable efforts to obtain such consent. If consent is obtained, World Rugby, the Union, Association or Tournament Organiser shall Publicly Disclose the decision in its entirety or in such redacted form as the Player or other Person may approve.

**21.14.3.4** Publication shall be accomplished at a minimum by placing the required information on World Rugby, the Union, Association or Tournament Organiser's website or publishing it through other means and leaving the information up for the longer of one month or the duration of any period of Ineligibility.

**21.14.3.5** None of World Rugby, the Union, Association or Tournament Organiser, nor any official of either body, shall publicly comment on the specific facts of any pending case (as opposed to general description of process and science) except in response to public comments attributed to the Player or other Person against whom an anti-doping rule violation is asserted, or their representatives.

**21.14.3.6** The mandatory Public Reporting required in Regulation 21.14.3.2 shall not be required where the Player or other Person who has been found to have committed an anti-doping rule violation is a Minor. Any optional Public Reporting in a case involving a Minor shall be proportionate to the facts and circumstances of the case.

#### **21.14.4 Statistical Reporting**

World Rugby shall publish at least annually a general statistical report of its Doping Control activities, with a copy provided to WADA. World Rugby and/or Unions may also publish reports showing the name of each Player tested and the date of each Testing.

#### **21.14.5 Doping Control Information Clearinghouse**

To facilitate coordinated test distribution planning and to avoid unnecessary duplication in Testing by the various Anti-Doping Organisations, World Rugby shall report all In-Competition and Out-of-Competition tests on such Players to the WADA clearinghouse, using ADAMS, as soon as possible after such tests have been conducted. This information will be made accessible, where appropriate and in accordance with the applicable rules, to the Player, the Player's National Anti-Doping Organisation and any other Anti-Doping Organisations with Testing authority over the Player.

#### **21.14.6 Data Privacy**

**21.14.6.1** World Rugby may collect, store, process or disclose personal information relating to Players and other Persons where necessary and appropriate to conduct their anti-doping activities under the Code, the International Standards (including specifically the International Standard for the Protection of Privacy and Personal Information) and these Anti-Doping Rules.

**21.14.6.2** Any Participant who submits information including personal data to any Person in accordance with these Anti-Doping Rules shall be deemed to have agreed, pursuant to applicable data protection laws and otherwise, that such information may be collected, processed, disclosed and used by such Person for the purposes of the implementation of these Anti-Doping Rules, in accordance with the International Standard for the Protection of Privacy and Personal Information and otherwise as required to implement these Anti-Doping Rules.

## **21.15 APPLICATION AND RECOGNITION OF DECISIONS**

**21.15.1** Subject to the right to appeal provided in Regulation 21.13, Testing, hearing results or other final adjudications of any Signatory which are consistent with the Code and are within that Signatory's authority shall be applicable worldwide and shall be recognised and respected by World Rugby and all its Member Unions and Associations. [See [Comment 49](#)]

**21.15.2** World Rugby and its Member Unions and Associations shall recognise the measures taken by other bodies which have not accepted the Code if the rules of those bodies are otherwise consistent with the Code. [See [Comment 50](#)]

**21.15.3** Subject to the right to appeal provided in Regulation 21.13, any decision of World Rugby regarding a violation of these Anti-Doping Rules shall be recognised by all Member Unions and Associations, which shall take all necessary action to render such decision effective.

## **21.16 INCORPORATION OF WORLD RUGBY ANTI-DOPING RULES AND OBLIGATIONS OF MEMBER UNIONS**

**21.16.1** All Member Unions and their members shall comply with these Anti-Doping Rules. All Member Unions and other members shall include in their regulations the provisions necessary to ensure that World Rugby may enforce these Anti-Doping Rules directly as against Players and other Persons under their anti-doping jurisdiction (including National-Level Players). These Anti-Doping Rules shall also be incorporated either directly or by reference into each Member Union's rules so that the Member Union may enforce them itself directly as against Players and other Persons under its anti-doping jurisdiction (including National-Level Players).

**21.16.2** All Member Unions shall establish rules requiring all Players and each Player Support Personnel who participates as coach, trainer, manager, team staff, official, medical or paramedical personnel in a Competition or activity authorised or organised by a Member Union or Association or one of its or their member organisations to agree to be bound by these Anti-Doping Rules and to submit to the results management authority of the Anti-Doping Organisation responsible under the Code as a condition of such participation.

**21.16.3** All Member Unions shall report any information suggesting or relating to an anti-doping rule violation to World Rugby and to their National Anti-Doping

Organisations, and shall cooperate with investigations conducted by any Anti-Doping Organisation with authority to conduct the investigation.

**21.16.4** All Member Unions shall have disciplinary rules in place to prevent Player Support Personnel who are Using Prohibited Substances or Prohibited Methods without valid justification from providing support to Players under the jurisdiction of World Rugby or the Member Union.

**21.16.5** All Member Unions shall be required to conduct anti-doping education in coordination with their National Anti-Doping Organisations, as applicable.

## **21.17 STATUTE OF LIMITATIONS**

No anti-doping rule violation proceeding may be commenced against a Player or other Person unless he or she has been notified of the anti-doping rule violation as provided in Regulation 21.7, or notification has been reasonably attempted, within ten years from the date the violation is asserted to have occurred.

## **21.18 WORLD RUGBY COMPLIANCE REPORTS TO WADA**

World Rugby will report to WADA on its compliance with the Code in accordance with Article 23.5.2 of the Code.

## **21.19 EDUCATION**

**21.19.1** World Rugby shall plan, implement, evaluate and monitor information, education and prevention programmes for doping-free sport on at least the issues listed at Article 18.2 of the Code, and shall support active participation by Players and Player Support Personnel in such programmes.

**21.19.2** Each Union shall within its means and in co-operation with its constituents, plan, implement, evaluate and monitor information and education programmes for doping-free rugby and shall support the programmes of World Rugby set out above.

## **21.20 AMENDMENT AND INTERPRETATION OF ANTI-DOPING RULES**

**21.20.1** These Anti-Doping Rules may be amended from time to time by World Rugby.

**21.20.2** These Anti-Doping Rules shall be interpreted as an independent and autonomous text and not by reference to existing law or statutes.

**21.20.3** The headings used for the various Parts and Regulations of these Anti-Doping Rules are for convenience only and shall not be deemed part of the substance of these Anti-Doping Rules or to affect in any way the language of the provisions to which they refer save in respect of Regulation 21.2.

**21.20.4** The Code and the International Standards shall be considered integral parts of these Anti-Doping Rules and shall prevail in case of conflict. In addition to the Code and these Anti-Doping Rules, adherence to the International Standards are mandatory. WADA may revise the International

Standards from time to time. Any changes to WADA's International Standards will be deemed to be effective as at the date prescribed by WADA. The mandatory standards in force are available at [www.wada-ama.org](http://www.wada-ama.org).

- 21.20.5** These Anti-Doping Rules have been adopted pursuant to the applicable provisions of the Code and shall be interpreted in a manner that is consistent with applicable provisions of the Code. The Introduction shall be considered an integral part of these Anti-Doping Rules.
- 21.20.6** The comments annotating various provisions of the Code are set out in Appendix 2 to these Anti-Doping Rules and shall be used to interpret these Anti-Doping Rules. These comments may be incorporated by reference into any anti-doping rules produced by Unions, Tournament Organisers and/or World Rugby for the purposes of particular Tournaments.
- 21.20.7** These Anti-Doping Rules have come into full force and effect on 1 January 2015 (the "Effective Date"). They shall not apply retroactively to matters pending before the Effective Date; provided, however, that:
- 21.20.7.1** Anti-doping rule violations taking place prior to the Effective Date count as "first violations" or "second violations" for purposes of determining sanctions under Regulation 21.10 for violations taking place after the Effective Date.
- 21.20.7.2** The retrospective period in which prior violations can be considered for purposes of multiple violations under Regulation 21.10.7.5 and the statute of limitations set forth in Regulation 21.17 are procedural rules and should be applied retroactively; provided, however, that Regulation 21.17 shall only be applied retroactively if the statute of limitations period has not already expired by the Effective Date. Otherwise, with respect to any anti-doping rule violation case which is pending as of the Effective Date and any anti-doping rule violation case brought after the Effective Date based on an anti-doping rule violation which occurred prior to the Effective Date, the case shall be governed by the substantive anti-doping rules in effect at the time the alleged anti-doping rule violation occurred unless the panel hearing the case determines the principle of "lex mitior" appropriately applies under the circumstances of the case.
- 21.20.7.3** Any Regulation 21.2.4 whereabouts failure (whether a filing failure or a missed test, as those terms are defined in the International Standard for Testing and Investigations) prior to the Effective Date shall be carried forward and may be relied upon, prior to expiry, in accordance with the International Standard for Testing and Investigation, but it shall be deemed to have expired 12 months after it occurred.
- 21.20.7.4** With respect to cases where a final decision finding an anti-doping rule violation has been rendered prior to the Effective Date, but the Player or other Person is still serving the period of Ineligibility as of the Effective Date, the Player or other Person may apply to the Anti-Doping Organisation which had results management responsibility for the anti-doping rule violation to consider a reduction in the period of Ineligibility in light of these Anti-Doping



Rules. Such application must be made before the period of Ineligibility has expired. The decision rendered may be appealed pursuant to Regulation 21.13.2. These Anti-Doping Rules shall have no application to any case where a final decision finding an anti-doping rule violation has been rendered and the period of Ineligibility has expired.

**21.20.7.5** For purposes of assessing the period of Ineligibility for a second violation under Regulation 21.10.7.1, where the sanction for the first violation was determined based on rules in force prior to the Effective Date, the period of Ineligibility which would have been assessed for that first violation had these Anti-Doping Rules been applicable, shall be applied.

## **21.21 INTERPRETATION OF THE CODE**

**21.21.1** The official text of the Code shall be maintained by WADA and shall be published in English and French. In the event of any conflict between the English and French versions, the English version shall prevail.

**21.21.2** The comments annotating various provisions of the Code shall be used to interpret the Code.

**21.21.3** The Code shall be interpreted as an independent and autonomous text and not by reference to the existing law or statutes of the Signatories or governments.

**21.21.4** The headings used for the various Parts and Articles of the Code are for convenience only and shall not be deemed part of the substance of the Code or to affect in any way the language of the provisions to which they refer.

**21.21.5** The Code shall not apply retroactively to matters pending before the date the Code is accepted by a Signatory and implemented in its rules. However, pre-Code anti-doping rule violations would continue to count as "first violations" or "second violations" for purposes of determining sanctions under Article 10 of the Code and Regulation 21.10 for subsequent post-Code violations.

**21.21.6** The Purpose, Scope and Organisation of the World Anti-Doping Programme and the Code and the Code's APPENDIX 1, DEFINITIONS and APPENDIX 2, EXAMPLES OF THE APPLICATION OF ARTICLE 10, shall be considered integral parts of the Code.

## **21.22 ADDITIONAL ROLES AND RESPONSIBILITIES OF PLAYERS AND OTHER PERSONS**

### **21.22.1 Roles and Responsibilities of Players**

**21.22.1.1** To be knowledgeable of and comply with these Anti-Doping Rules including the Guidelines.

**21.22.1.2** To be available for Sample collection at all times. [See [Comment 51](#)]

- 21.22.1.3** To take responsibility, in the context of anti-doping, for what they ingest and Use and, specifically, to ensure that no Prohibited Substance is found to be present in his body and that Prohibited Methods are not used.
- 21.22.1.4** To inform medical personnel of their obligation not to Use Prohibited Substances and Prohibited Methods and to take responsibility to make sure that any medical treatment received does not violate these Anti-Doping Rules.
- 21.22.1.5** To ensure that he does not commit any other anti-doping rule violation.
- 21.22.1.6** To disclose to his National Anti-Doping Organisation, Union and World Rugby any decision by a non-Signatory finding that the Player committed an anti-doping rule violation within the previous ten years and/or has been convicted or found in a criminal, disciplinary or professional proceeding to have engaged in conduct which would have constituted a violation of anti-doping rules if Code-compliant rules had been applicable to such Person.
- 21.22.1.7** To cooperate with Anti-Doping Organisations investigating anti-doping rule violations.
- 21.22.1.8** Failure by any Player to cooperate in full with World Rugby and/or any other Anti-Doping Organisation(s) investigating anti-doping rule violations may amount to Misconduct. In such circumstances, World Rugby may accordingly bring a Misconduct charge against such Player pursuant to this Regulation 22.1.8 and World Rugby Regulation 20 which shall be determined in accordance with World Rugby Regulation 18. A Union and/or other Anti-Doping Organisation may bring a Misconduct or similar appropriate charge pursuant to its applicable disciplinary regulations.
- 21.22.2 Roles and Responsibilities of Player Support Personnel**
- 21.22.2.1** To be knowledgeable of and comply with these Anti-Doping Rules including the Guidelines.
- 21.22.2.2** To cooperate with the Player Testing programme.
- 21.22.2.3** To use their influence on Player values and behaviour to foster anti-doping attitudes.
- 21.22.2.4** To educate and counsel Players regarding anti-doping policies and these Anti-Doping Rules.
- 21.22.2.5** To ensure that he does not commit any other anti-doping rule violation.
- 21.22.2.6** To disclose to his National Anti-Doping Organisation, Union and World Rugby any decision by a non-Signatory finding that he or she committed an anti-doping rule violation within the previous ten years and/or has been convicted or found in a criminal, disciplinary or professional proceeding to have engaged in conduct which would have constituted a violation of anti-doping rules if Code-compliant rules had been applicable to such Person.
- 21.22.2.7** To cooperate with Anti-Doping Organisations investigating anti-doping rule violations.

**21.22.2.8** Player Support Personnel shall not Use or Possess any Prohibited Substance or Prohibited Method without valid justification.

**21.22.2.9** Failure by any Player Support Personnel to cooperate in full with World Rugby and/or any other Anti-Doping Organisation(s) investigating anti-doping rule violations and/or Use or Possession of a Prohibited Substance or Prohibited Method by a Player Support Personnel without valid justification may amount to Misconduct. In such circumstances, World Rugby may accordingly bring a Misconduct charge against the Player Support Personnel pursuant to this Regulation 21.22.2.9 and Regulation 20 which shall be determined in accordance with Regulation 18. A Union and/or other Anti-Doping Organisation may bring a Misconduct or similar appropriate charge pursuant to its applicable disciplinary regulations.

### **21.23 ADDITIONAL ROLES AND RESPONSIBILITIES OF UNIONS**

In addition to the roles and responsibilities of Unions set out throughout these Anti-Doping Rules, each Union is also responsible for ensuring (and must ensure) that:

**21.23.1** It has in place anti-doping regulations in conformity with these Anti-Doping Rules and that all national level Testing on Players complies with these Anti-Doping Rules.

**21.23.2** These Anti-Doping Rules shall also be incorporated either directly or by reference into each Union's rules. All Unions shall include in their regulations the procedural rules necessary to implement these Anti-Doping Rules effectively.

**21.23.3** It shall seek to obtain the written acknowledgement of all Players subject to Doping Control and Player Support Personnel for such Players (i.e. acknowledgement that they are bound by the relevant anti-doping regulations). A standard acknowledgment and agreement form is set out in Schedule 4 to these Anti-Doping Rules.

**21.23.4** Its regulations specifically provide that all Players, Player Support Personnel and other Persons under the jurisdiction of the Union shall be bound by these Anti-Doping Rules.

**21.23.5** It takes appropriate action to inform each and every one of its members, Players and other Persons of these Anti-Doping Rules and the Union's anti-doping regulations. Unions must further inform their members, Players and other Persons that they must comply with these Anti-Doping Rules and the anti-doping regulations of the Union under whose jurisdiction they are participating.

World Rugby may at its absolute discretion withhold some or all of its funding to Unions that are not in compliance with these Anti-Doping Rules.

### **21.24 WORLD RUGBY ANTI-DOPING ADVISORY COMMITTEE**

**21.24.1** World Rugby shall appoint an Anti-Doping Advisory Committee to provide World Rugby with general advice and assistance on doping issues and

related matters, including the application of these Anti-Doping Rules. The Anti-Doping Advisory Committee shall report to the Council.

- 21.24.2** In addition to this general role, the Anti-Doping Advisory Committee, or a member or members thereof may be requested to undertake specific tasks as part of the implementation of these Anti-Doping Rules.
- 21.24.3** Members of the Anti-Doping Advisory Committee may sit on World Rugby's TUE Committee, Judicial Committees and on Post-Hearing Review Bodies from time to time.
- 21.24.4** The Anti-Doping Advisory Committee and/or World Rugby shall be entitled to call on experts to provide specialist advice, undertake certain activities and assist in the implementation of these Anti-Doping Rules including but not limited to undertaking preliminary reviews of cases pursuant to Regulation 21.7.2.2.

## **21.25 REPORTING REQUIREMENTS**

- 21.25.1** Without limiting the reporting and notification requirements set out in Regulations 21.7.12.4, 21.7.14.1, 21.7.14.2 and 21.13.8.17 each Union, Association or Tournament Organiser (as the case may be) shall submit to the World Rugby Anti-Doping Manager a full report of the proceedings and conclusions of all hearings resulting from anti-doping rule violations arising out of or within its jurisdiction within 72 hours of the final written decision on the anti-doping rule violation having been made. Such cases shall be considered by the World Rugby Anti-Doping Manager who, on behalf of World Rugby shall be entitled to (a) request the case file (including an English translation where required), and/or (b) accept the result and decision or (c) refer the matter to a representative(s) of World Rugby's Anti-Doping Advisory Committee who on behalf of World Rugby may accept the result and decision or subject to these Anti-Doping Rules refer the matter to a post-hearing review body or appeal the matter to CAS, through World Rugby. Following the referral of a first instance decision by the World Rugby Anti-Doping Manager to a representative(s) of World Rugby's Anti-Doping Advisory Committee, the representative(s) of the Anti-Doping Advisory Committee shall undertake the review as expeditiously as possible and in the event that he/they elects to refer the matter to a post-hearing review body or appeal to CAS he/they shall do so no later than 28 days from receipt of the full, English translation (where required) of the case file by World Rugby from the Union (and/or national sports resolution body as applicable) and/or Association as relevant. Notwithstanding the foregoing, both the World Rugby Anti-Doping Manager and/or representatives of World Rugby's Anti-Doping Advisory Committee may take such other steps and/or make such other recommendations to World Rugby as they deem appropriate.
- 21.25.2** If the CEO of World Rugby or his nominee believes that a Union is not applying, or in a particular case did not apply, these Anti-Doping Rules and/or the Guidelines, or failed to apply these Anti-Doping Rules properly or in good faith, that Union renders itself liable to disciplinary action.

- 21.25.3** World Rugby shall publish annually a general statistical report of its Doping Control activities during the calendar year with a copy provided to WADA and World Rugby may periodically publish testing data received from Unions.
- 21.25.4** The Unions shall report to World Rugby at the end of every year the results of all Doping Controls within their jurisdiction sorted by Player and identifying each date on which the Player was tested, the entity conducting the test, and whether the test was In Competition or Out of Competition.
- 21.25.5** World Rugby shall provide to WADA information supplied by Unions, Associations, Tournament Organisers and/or National Anti-Doping Organisations in relation to these Anti-Doping Rules and the anti-doping rules of the Union, Association and/or Tournament Organiser concerned. World Rugby shall in the case of an Adverse Analytical Finding or anti-doping rule violation notify WADA upon completion of the initial hearing before a Judicial Committee and upon notification by a Union, Association, Tournament Organiser or National Anti-Doping Organisation of the findings/decisions of its hearing bodies.
- 21.25.6** World Rugby will report to WADA on its compliance with the Code every second year.

### **21.26 EXCEPTIONAL CIRCUMSTANCES**

- 21.26.1** In exceptional circumstances where it has grounds to believe that there has been a misapplication of the applicable anti-doping rules and acting on the advice of the Anti-Doping Advisory Committee, World Rugby shall be entitled to require as it deems fit that the relevant Union(s) provisionally suspend such Players or other Person(s) from any involvement in the Game pending the final determination of the matter.
- 21.26.2** It is the responsibility of each Union to ensure that in such circumstances it is able by reference to its anti-doping regulations or otherwise, to effect and/or recognise such Provisional Suspension of the Players or other Person(s) concerned.

### **21.27 UNFORESEEN CIRCUMSTANCES**

In the event that a doping-related incident arises for which there is no provision in these Anti-Doping Rules then the CEO of World Rugby or his nominee may take such action that he considers appropriate in the circumstances in accordance with general principles of natural justice and fairness.

### **21.28 GENERAL**

- 21.28.1** Any deviation or deviations from these Anti-Doping Rules and/or the Guidelines does not invalidate any finding, decision or Adverse Analytical Finding unless such deviation or deviations are such as to cast material doubt on any finding, decision or Adverse Analytical Finding.

- 21.28.2** (a) Representatives of the Anti-Doping Advisory Committee shall on behalf of World Rugby and on behalf of all Unions recognise anti-doping rule violations arising out of anti-doping programmes carried out by Signatories to the Code.
- (b) The Anti-Doping Advisory Committee may, on behalf of World Rugby and all Unions, recognise anti-doping rule violations arising out of, and sanctions imposed under anti-doping programmes of a sporting body other than World Rugby, Unions or Tournament Organisers, or Signatories (or by a member of another sporting body), under rules and procedures different from those of World Rugby, as long as the applicable rules and procedures are consistent with the provisions of the Code.
- (c) Unions shall recognise anti-doping rule violations committed, and sanctions imposed, under the rules of another sporting body and make provision to ensure that the Persons who are subject to such sanctions are unable to play, coach, train or provide any other assistance in any other capacity in connection with the Game. This is applicable at any level of the Game and for the same period of Ineligibility sanctioned in relation to the sport in respect of which the anti-doping rule violation was committed. For the avoidance of doubt, the burden is on a person who is subject to a suspension imposed under the rules of another sporting body to prove that he should be entitled to play the Game on the grounds that the suspension he has received was improperly complied with.
- 21.28.3** World Rugby may amend these Anti-Doping Rules from time to time.
- 21.28.4** World Rugby shall do everything possible to award world championships only to countries in which the government has ratified, accepted, approved or acceded to the UNESCO Convention.
- 21.28.5** These Anti-Doping Rules shall be governed by and construed in accordance with English law and, subject to the dispute resolution processes set out herein, shall be subject to the exclusive jurisdiction of the English courts.

## APPENDIX 1. DEFINITIONS

ADAMS: The Anti-Doping Administration and Management System is a Web-based database management tool for data entry, storage, sharing, and reporting designed to assist stakeholders and WADA in their anti-doping operations in conjunction with data protection legislation.

Administration: Providing, supplying, supervising, facilitating, or otherwise participating in the Use or Attempted Use by another Person of a Prohibited Substance or Prohibited Method. However, this definition shall not include the actions of bona fide medical personnel involving a Prohibited Substance or Prohibited Method used for genuine and legal therapeutic purposes or other acceptable justification and shall not include actions involving Prohibited Substances which are not prohibited in Out-of-Competition Testing unless the circumstances as a whole demonstrate that such Prohibited Substances are not intended for genuine and legal therapeutic purposes or are intended to enhance sport performance.

Adverse Analytical Finding: A report from a WADA-accredited laboratory or other WADA-approved laboratory that, consistent with the International Standard for Laboratories and related Technical Documents, identifies in a Sample the presence of a Prohibited Substance or its Metabolites or Markers (including elevated quantities of endogenous substances) or evidence of the Use of a Prohibited Method.

Adverse Passport Finding: A report identified as an Adverse Passport Finding as described in the applicable International Standards.

Anti-Doping Organisation: A Signatory that is responsible for adopting rules for initiating, implementing or enforcing any part of the Doping Control process. This includes, for example, the International Olympic Committee, the International Paralympic Committee, other Major Event Organisations that conduct Testing at their Events, WADA, World Rugby, other International Federations and National Anti-Doping Organisations.

Attempt: Purposely engaging in conduct that constitutes a substantial step in a course of conduct planned to culminate in the commission of an anti-doping rule violation. Provided, however, there shall be no anti-doping rule violation based solely on an Attempt to commit a violation if the Person renounces the Attempt prior to it being discovered by a third party not involved in the Attempt.

Atypical Finding: A report from a WADA-accredited laboratory or other WADA-approved laboratory which requires further investigation as provided by the International Standard for Laboratories or related Technical Documents prior to the determination of an Adverse Analytical Finding.

Atypical Passport Finding: A report described as an Atypical Passport Finding as described in the applicable International Standards.

CAS: The Court of Arbitration for Sport.

Code: The World Anti-Doping Code.

Competition: A single Match whether in fifteen-a-side or an abbreviated form of the Game.

Consequences of Anti-Doping Rule Violations (“Consequences”): A Player's or other Person's violation of an anti-doping rule may result in one or more of the following: (a) Disqualification means the Player's results in a particular Competition or Event are invalidated, with all resulting Consequences including forfeiture of any medals, points and prizes; (b) Ineligibility means the Player or other Person is barred on account of an anti-doping rule violation for a specified period of time from participating in any Competition or other activity or funding as provided in Regulation 21.10.12.1; (c) Provisional Suspension means the Player or other Person is barred temporarily from participating in any Competition or activity prior to the final decision at a hearing conducted under Regulation 21.8; (d) Financial Consequences means a financial sanction imposed for an anti-doping rule violation or to recover costs associated with an anti-doping rule violation; and (e) Public Disclosure or Public Reporting means the dissemination or distribution of information to the general public or Persons beyond those Persons entitled to earlier notification in accordance with Regulation 21.14. Teams may also be subject to Consequences as provided in Regulation 21.11.

Contaminated Product: A product that contains a Prohibited Substance that is not disclosed on the product label or in information available in a reasonable Internet search.

Disqualification: See Consequences of Anti-Doping Rule Violations above.

Doping Control: All steps and processes from test distribution planning through to ultimate disposition of any appeal including all steps and processes in between such as provision of whereabouts information, Sample collection and handling, laboratory analysis, TUEs, results management and hearings.

Event: A series of individual Competitions conducted together under one ruling body (e.g., the Olympic Games, FINA World Championships, or Pan American Games).

Event Venues: Those venues so designated by the ruling body for the Event.

Event Period: The time between the beginning and end of an Event, as established by the ruling body of the Event.

Fault: Fault is any breach of duty or any lack of care appropriate to a particular situation. Factors to be taken into consideration in assessing a Player or other Person's degree of Fault include, for example, the Player's or other Person's experience, whether the Player or other Person is a Minor, special considerations such as impairment, the degree of risk that should have been perceived by the Player and the level of care and investigation exercised by the Player in relation to what should have been the perceived level of risk. In assessing the Player's or other Person's degree of Fault, the circumstances considered must be specific and relevant to explain the Player's or other Person's departure from the expected standard of behaviour. Thus, for example, the fact that a Player would lose the opportunity to earn large sums of money during a period of Ineligibility, or the fact that the Player only has a short time left in his or her career, or the timing of the sporting calendar, would not be relevant factors to be considered in reducing the period of Ineligibility under Regulation 21.10.5.1 or 21.10.5.2. [See [Comment 52](#)]

Financial Consequences: see Consequences of Anti-Doping Rule Violations, above.



In Competition: “In Competition” means the period commencing twelve hours before a Competition in which the Player is scheduled to participate through until the end of such Competition and the Sample collection process related to such Competition, save where a Sample collection session cannot be completed after a Competition then the Anti-Doping Commissioner or Doping Control Officer may extend the period of In Competition up to a maximum of 24 hours from the conclusion of the Match. In such cases the Player shall be formally notified that any further Sample collection taken within the extended period up to 24 hours of the conclusion of the Match shall be deemed to be In Competition whether or not the Player is chaperoned during such period. Notwithstanding the foregoing, World Rugby, Unions, Associations and Tournament Organisers may impose an extended In-Competition period with respect to a particular Event under their jurisdiction including without limitation to extend the In-Competition period to the entire duration of the Event. [See [Comment 53](#)]

Independent Observer Program: A team of observers, under the supervision of WADA, who observe and provide guidance on the Doping Control process at certain Events and report on their observations.

Individual Sport: Any sport that is not a Team Sport.

Ineligibility: See Consequences of Anti-Doping Rule Violations above.

International Event: An Event or Competition where the International Olympic Committee, the International Paralympic Committee, World Rugby, an Association, International Tournament Organiser, Major Event Organisation, or another international sport organisation is the ruling body for the Event or appoints the technical officials for the Event.

International-Level Player: Players who compete in sport at the international level, as defined by World Rugby, consistent with the International Standard for Testing and Investigations. In Rugby International-Level Players are those Players who are designated by World Rugby as being within its Registered Testing Pool and/or Testing Pool and/or otherwise who are participating in a World Rugby Event(s) and/or Competition(s). [See [Comment 54](#)]

International Standard: A standard adopted by WADA in support of the Code. Compliance with an International Standard (as opposed to another alternative standard, practice or procedure) shall be sufficient to conclude that the procedures addressed by the International Standard were performed properly. International Standards shall include any Technical Documents issued pursuant to the International Standard.

Major Event Organisations: The continental associations of National Olympic Committees and other international multi-sport organisations that function as the ruling body for any continental, regional or other International Event.

Marker: A compound, group of compounds or biological variable(s) that indicates the Use of a Prohibited Substance or Prohibited Method.

Member of a Team: Any Player and/or other Participant associated with a team including for the avoidance of doubt without limitation all coaches, medical and other similar Player Support Personnel.

Metabolite: Any substance produced by a biotransformation process.

Minor: A natural Person who has not reached the age of eighteen years.

National Anti-Doping Organisation (NADO): The entity(ies) designated by each country as possessing the primary authority and responsibility to adopt and implement anti-doping rules, direct the collection of Samples, the management of test results, and the conduct of hearings at the national level. If this designation has not been made by the competent public authority(ies), the entity shall be the country's National Olympic Committee or its designee. The acronym "NADO" shall also include reference to a Regional Anti-Doping Organisation, as applicable, within these Regulations.

National Event: A sport Event or Competition involving International- or National-Level Players that is not an International Event.

National-Level Player: Players who compete in sport at the national level, as defined by each National Anti-Doping Organisation, consistent with the International Standard for Testing and Investigations.

National Olympic Committee: The organisation recognised by the International Olympic Committee. The term National Olympic Committee shall also include the National Sport Confederation in those countries where the National Sport Confederation assumes typical National Olympic Committee responsibilities in the anti-doping area.

No Fault or Negligence: The Player or other Person's establishing that he or she did not know or suspect, and could not reasonably have known or suspected even with the exercise of utmost caution, that he or she had Used or been administered the Prohibited Substance or Prohibited Method or otherwise violated an anti-doping rule. Except in the case of a Minor, for any violation of Regulation 21.2.1, the Player must also establish how the Prohibited Substance entered his or her system.

No Significant Fault or Negligence: The Player or other Person's establishing that his or her Fault or Negligence, when viewed in the totality of the circumstances and taking into account the criteria for No Fault or Negligence, was not significant in relationship to the anti-doping rule violation. Except in the case of a Minor, for any violation of Regulation 21.2.1, the Player must also establish how the Prohibited Substance entered his or her system. [See [Comment 55](#)]

Out-of-Competition: Any period which is not In-Competition.

Participant: Any Player or Player Support Personnel.

Person: A natural Person or an organisation or other entity.

Player: Any Person who competes in sport at the international level (as defined by World Rugby), or the national level (as defined by each National Anti-Doping Organisation). An Anti-Doping Organisation has discretion to apply anti-doping rules to a Player who is neither an International-Level Player nor a National-Level Player, and thus to bring them within the definition of "Player." In relation to Players who are neither International-Level nor National-Level Players, an Anti-Doping Organisation may elect to: conduct limited Testing or no Testing at all; analyse Samples for less than the full menu of Prohibited Substances; require limited or no whereabouts

information; or not require advance TUEs. However, if a Regulation 21.2.1 (Presence), 21.2.3 (Evading) or 21.2.5 (Tampering) anti-doping rule violation is committed by any Player over whom an Anti-Doping Organisation has authority who competes below the international or national level, then the Consequences set forth in the Code (except Article 14.3.2) must be applied. For purposes of Regulation 21.2.8 (Administration) and 21.2.9 (Complicity) and for purposes of anti-doping information and education, any Person who participates in sport under the authority of any Signatory, government, or other sports Organisation accepting the Code is a Player. [See [Comment 56](#)]

Player Biological Passport: The programme and methods of gathering and collating data as described in the International Standard for Testing and Investigations and International Standard for Laboratories.

Player Support Personnel: Any coach, trainer, manager, agent, Team staff, official, medical, paramedical personnel, parent or any other Person working with, treating or assisting a Player (or Team) participating in or preparing for sports Competition. This includes preparation in and out of season.

Possession: The actual, physical Possession, or the constructive Possession (which shall be found only if the Person has exclusive control or intends to exercise control over the Prohibited Substance or Prohibited Method or the premises in which a Prohibited Substance or Prohibited Method exists); provided, however, that if the Person does not have exclusive control over the Prohibited Substance or Prohibited Method or the premises in which a Prohibited Substance or Prohibited Method exists, constructive Possession shall only be found if the Person knew about the presence of the Prohibited Substance or Prohibited Method and intended to exercise control over it. Provided, however, there shall be no anti-doping rule violation based solely on Possession if, prior to receiving notification of any kind that the Person has committed an anti-doping rule violation, the Person has taken concrete action demonstrating that the Person never intended to have Possession and has renounced Possession by explicitly declaring it to an Anti-Doping Organisation. Notwithstanding anything to the contrary in this definition, the purchase (including by any electronic or other means) of a Prohibited Substance or Prohibited Method constitutes Possession by the Person who makes the purchase. [See [Comment 57](#)]

Prohibited List: The List identifying the Prohibited Substances and Prohibited Methods.

Prohibited Method: Any method so described on the Prohibited List.

Prohibited Substance: Any substance, or class of substances, so described on the Prohibited List.

Provisional Hearing: For purposes of Regulation 21.7.9, an expedited abbreviated hearing occurring prior to a hearing under Regulation 21.8 that provides the Player with notice and an opportunity to be heard in either written or oral form. [See [Comment 58](#)]

Provisional Suspension: See Consequences of Anti-Doping Rule Violations above.

Publicly Disclose or Publicly Report: See Consequences of Anti-Doping Rule Violations above.

Regional Anti-Doping Organisation: A regional entity designated by member countries to coordinate and manage delegated areas of their national anti-doping programs, which may include the adoption and implementation of anti-doping rules, the planning and collection of Samples, the management of results, the review of TUEs, the conduct of hearings, and the conduct of educational programs at a regional level.

Registered Testing Pool: The pool of highest-priority Players established separately at the international level by World Rugby and at the national level by National Anti-Doping Organisations, who are subject to focused In-Competition and Out-of-Competition Testing as part of World Rugby or National Anti-Doping Organisation's test distribution plan and therefore are required to provide whereabouts information as provided in Article 5.6 of the Code and the International Standard for Testing and Investigations.

Sample or Specimen: Any biological material collected for the purposes of Doping Control. [See [Comment 59](#)]

Series of (International) Matches: Two or more (International) Matches.

Signatories: Those entities signing the Code and agreeing to comply with the Code, as provided in Article 23 of the Code.

Specified Substance: See Regulation 21.4.2.2.

Strict Liability: The rule which provides that under Regulations 21.2.1 (Presence) and 21.2.2 (Use or Attempted Use), it is not necessary that intent, Fault, negligence, or knowing Use on the Player's part be demonstrated by the Anti-Doping Organisation in order to establish an anti-doping rule violation.

Substantial Assistance: For purposes of Regulation 21.10.6.1, a Person providing Substantial Assistance must: (1) fully disclose in a signed written statement all information he or she possesses in relation to anti-doping rule violations, and (2) fully cooperate with the investigation and adjudication of any case related to that information, including, for example, presenting testimony at a hearing if requested to do so by an Anti-Doping Organisation or hearing panel. Further, the information provided must be credible and must comprise an important part of any case which is initiated or, if no case is initiated, must have provided a sufficient basis on which a case could have been brought.

Tampering: Altering for an improper purpose or in an improper way; bringing improper influence to bear; interfering improperly; obstructing, misleading or engaging in any fraudulent conduct to alter results or prevent normal procedures from occurring.

Target Testing: Selection of specific Players for Testing based on criteria set forth in the International Standard for Testing and Investigations.

Team Sport: A sport in which the substitution of players is permitted during a Competition. For the avoidance of doubt, the Game, including all forms thereof, is a Team Sport.

Testing: The parts of the Doping Control process involving test distribution planning, Sample collection, Sample handling, and Sample transport to the laboratory.

Testing Pool: Any International-Level Player who is eligible to be part of World Rugby's Out of Competition Testing programme and who is not part of World Rugby's Registered Testing Pool.

Trafficking: Selling, giving, transporting, sending, delivering or distributing (or Possessing for any such purpose) a Prohibited Substance or Prohibited Method (either physically or by any electronic or other means) by a Player, Player Support Person or any other Person subject to the jurisdiction of an Anti-Doping Organisation to any third party; provided, however, this definition shall not include the actions of "bona fide" medical personnel involving a Prohibited Substance used for genuine and legal therapeutic purposes or other acceptable justification, and shall not include actions involving Prohibited Substances which are not prohibited in Out-of-Competition Testing unless the circumstances as a whole demonstrate such Prohibited Substances are not intended for genuine and legal therapeutic purposes or are intended to enhance sport performance.

TUE: Therapeutic Use Exemption, as described in Regulation 21.4.4.

TUE Committee: The panel established by the relevant Anti-Doping Organisation to consider requests for TUEs.

UNESCO Convention: The International Convention against Doping in Sport adopted by the 33<sup>rd</sup> session of the UNESCO General Conference on 19 October, 2005 including any and all amendments adopted by the States Parties to the Convention and the Conference of Parties to the International Convention against Doping in Sport.

Use: The utilisation, application, ingestion, injection or consumption by any means whatsoever of any Prohibited Substance or Prohibited Method.

WADA: The World Anti-Doping Agency.

[See [Comment 60](#)]

All other terms which are capitalised in these Anti-Doping Rules and not defined herein shall have the meanings ascribed to them in Regulation 1.

## APPENDIX 2. COMMENTS

Comment 1 (Regulation 21.2.1.1): An anti-doping rule violation is committed under this Regulation without regard to a Player's Fault. This rule has been referred to in various CAS decisions as "Strict Liability". A Player's Fault is taken into consideration in determining the Consequences of this anti-doping rule violation under Regulation 21.10. This principle has consistently been upheld by CAS.

Comment 2 (Regulation 21.2.1.2): The Anti-Doping Organisation with results management responsibility may, at its discretion, choose to have the B Sample analysed even if the Player does not request the analysis of the B Sample.

Comment 3 (Regulation 21.2.2): It has always been the case that Use or Attempted Use of a Prohibited Substance or Prohibited Method may be established by any reliable means. As noted in the Comment to Regulation 21.3.2, unlike the proof required to establish an anti-doping rule violation under Regulation 21.2.1, Use or Attempted Use may also be established by other reliable means such as admissions by the Player, witness statements, documentary evidence, conclusions drawn from longitudinal profiling, including data collected as part of the Player Biological Passport, or other analytical information which does not otherwise satisfy all the requirements to establish "Presence" of a Prohibited Substance under Regulation 21.2.1 (Presence). For example, Use may be established based upon reliable analytical data from the analysis of an A Sample (without confirmation from an analysis of a B Sample) or from the analysis of a B Sample alone where the Anti-Doping Organisation provides a satisfactory explanation for the lack of confirmation in the other Sample.

Comment 4 (Regulation 21.2.2.2): Demonstrating the "Attempted Use" of a Prohibited Substance or a Prohibited Method requires proof of intent on the Player's part. The fact that intent may be required to prove this particular anti-doping rule violation does not undermine the Strict Liability principle established for violations of Regulation 21.2.1 (Presence) and violations of Regulation 21.2.2 (Use or Attempted Use) in respect of Use of a Prohibited Substance or Prohibited Method.

A Player's "Use" of a Prohibited Substance constitutes an anti-doping rule violation unless such substance is not prohibited Out-of-Competition and the Player's Use takes place Out-of-Competition. (However, the presence of a Prohibited Substance or its Metabolites or Markers in a Sample collected In-Competition is a violation of Regulation 21.2.1 (Presence) regardless of when that substance might have been administered).

Comment 5 (Regulation 21.2.3): For example, it would be an anti-doping rule violation of "evading Sample collection" if it were established that a Player was deliberately avoiding a Doping Control official to evade notification or Testing. A violation of "failing to submit to Sample collection" may be based on either intentional or negligent conduct of the Player, while "evading" or "refusing" Sample collection contemplates intentional conduct by the Player.

Comment 6 (Regulation 21.2.5): For example, this Regulation would prohibit altering identification numbers on a Doping Control form during Testing, breaking the B bottle at the time of B Sample analysis, or altering a Sample by the addition of a foreign

substance. Offensive conduct towards a Doping Control official or other Person involved in Doping Control which does not otherwise constitute Tampering shall be addressed pursuant to Regulation 20 and/or its equivalent in Unions' or Tournament Organisers' regulations.

Comment 7 (Regulation 21.2.6.1 and 21.2.6.2): Acceptable justification would not include, for example, buying or Possessing a Prohibited Substance for purposes of giving it to a friend or relative, except under justifiable medical circumstances where that Person had a physician's prescription, e.g., buying Insulin for a diabetic child.

Comment 8 (Regulation 21.2.6.2): Acceptable justification would include, for example, a team doctor carrying Prohibited Substances for dealing with acute and emergency situations.

Comment 9 (Regulation 21.2.10): Players and other Persons must not work with coaches, trainers, physicians or other Player Support Personnel who are Ineligible on account of an anti-doping rule violation or who have been criminally convicted or professionally disciplined in relation to doping. Some examples of the types of association which are prohibited include: obtaining training, strategy, technique, nutrition or medical advice; obtaining therapy, treatment or prescriptions; providing any bodily products for analysis; or allowing the Player Support Person to serve as an agent or representative. Prohibited association need not involve any form of compensation.

Comment 10 (Regulation 21.3.1): This standard of proof required to be met by World Rugby is comparable to the standard which is applied in most countries to cases involving professional misconduct.

Comment 11 (Regulation 21.3.2): For example, World Rugby may establish an anti-doping rule violation under Regulation 21.2.2 based on the Player's admissions, the credible testimony of third Persons, reliable documentary evidence, reliable analytical data from either an A or B Sample as provided in the Comments to Regulation 21.2.2, or conclusions drawn from the profile of a series of the Player's blood or urine Samples, such as data from the Player Biological Passport.

Comment 12 (Regulation 21.3.2.2): The burden is on the Player or other Person to establish, by a balance of probability, a departure from the International Standard for Laboratories that could reasonably have caused the Adverse Analytical Finding. If the Player or other Person does so, the burden shifts to World Rugby to prove to the comfortable satisfaction of the hearing panel that the departure did not cause the Adverse Analytical Finding.

Comment 13 (Regulation 21.4.1): The Prohibited List appears in Schedule 2 to these Anti-Doping Rules and is also always available in its full updated form and in a range of languages on WADA's website at [www.wada-ama.org](http://www.wada-ama.org).

Comment 14 (Regulation 21.4.2.2): The Specified Substances identified in Regulation 21.4.2.2 should not in any way be considered less important or less dangerous than other doping substances. Rather, they are simply substances which are more likely to have been consumed by a Player for a purpose other than the enhancement of sport performance.

Comment 15 (Regulation 21.4.4.1 – 21.4.4.3): Further to Articles 5.6 and 7.1(a) of the International Standard for Therapeutic Use Exemptions, World Rugby may publish notice on its website that it will automatically recognise TUE decisions (or categories of such decisions, e.g., as to particular substances or methods) made by National Anti-Doping Organisations. If a Player's TUE falls into a category of automatically recognised TUEs, then he does not need to apply to World Rugby for recognition of that TUE.

If World Rugby refuses to recognise a TUE granted by a National Anti-Doping Organisation only because medical records or other information are missing that are needed to demonstrate satisfaction of the criteria in the International Standard for Therapeutic Use Exemptions, the matter should not be referred to WADA. Instead, the file should be completed and re-submitted to World Rugby.

Comment 16 (Regulation 21.4.4.3): World Rugby may agree with a National Anti-Doping Organisation that the National Anti-Doping Organisation will consider TUE applications on behalf of World Rugby.

Comment 17 (Regulations 21.4.4.1 - 21.4.4.4): The submission of false or misleadingly incomplete information in support of a TUE application (including but not limited to the failure to advise of the unsuccessful outcome of a prior application to another Anti-Doping Organisation for such a TUE) may result in a charge of Tampering or Attempted Tampering under Regulation 21.2.5 (Tampering or Attempted Tampering).

A Player should not assume that his application for grant or recognition of a TUE (or for renewal of a TUE) will be granted. Any Use or Possession or Administration of a Prohibited Substance or Prohibited Method before an application has been granted is entirely at the Player's own risk.

Comment 18 (Regulation 21.4.4.6): In such cases, the decision being appealed is the World Rugby's TUE decision, not WADA's decision not to review the TUE decision or (having reviewed it) not to reverse the TUE decision. However, the deadline to appeal the TUE decision does not begin to run until the date that WADA communicates its decision. In any event, whether the decision has been reviewed by WADA or not, WADA shall be given notice of the appeal so that it may participate if it sees fit.

Comment 19 (Regulation 21.4.7.2): In such cases, the decision being appealed is World Rugby's TUE decision, not WADA's decision not to review the TUE decision or (having reviewed it) not to reverse the TUE decision. However, the time to appeal the TUE decision does not begin to run until the date that WADA communicates its decision. In any event, whether the decision has been reviewed by WADA or not, WADA shall be given notice of the appeal so that it may participate if it sees fit.

Comment 20 (Regulation 21.5.2.2): Unless the Player has identified a 60-minute time-slot for Testing between the hours of 11pm and 6am, or has otherwise consented to Testing during that period, World Rugby will not test a Player during that period unless it has a serious and specific suspicion that the Player may be engaged in doping. A challenge to whether World Rugby had sufficient suspicion for Testing in that period shall not be a defense to an anti-doping rule violation based on such test or attempted test.



Comment 21 (Regulation 21.5.7.7): Conduct by a Player or other Person before the Player or other Person was subject to the jurisdiction of any Anti-Doping Organisation would not constitute an anti-doping rule violation but could be a legitimate basis for denying the Player or other Person membership in a sports organisation.

Comment 22 (Regulation 21.6.1): Violations of Regulation 21.2.1 (Presence) may be established only by Sample analysis performed by a laboratory accredited or otherwise approved by WADA. Violations of other Regulations may be established using analytical results from other laboratories so long as the results are reliable.

Comment 23 (Regulation 21.6.2.1): For example, relevant profile information could be used to direct Target Testing or to support an anti-doping rule violation proceeding under Regulation 21.2.2 (Use or Attempted Use), or both.

Comment 24 (Regulation 21.6.4): The objective of this Regulation is to extend the principle of “intelligent Testing” to the Sample analysis menu so as to most effectively and efficiently detect doping. It is recognised that the resources available to fight doping are limited and that increasing the Sample analysis menu may, in some sports and countries, reduce the number of Samples which can be analysed.

Comment 25 (Regulation 21.7.9): Players and other Persons shall receive credit for a Provisional Suspension against any period of Ineligibility which is ultimately imposed. See Regulations 21.10.11.3.1 and 21.10.11.3.2.

Comment 26 (Regulation 21.8.1): For example, a hearing could be expedited on the eve of a major Event where the resolution of the anti-doping rule violation is necessary to determine the Player's eligibility to participate in the Event, or during an Event where the resolution of the case will affect the validity of a team's results or continued participation in the Event.

Comment 27 (Regulation 21.9): Any awards received by Players or other Persons will be Disqualified. However, Disqualification of the team will be as provided in Regulation 21.11.

Comment 28 (Regulation 21.10.3.3): Those who are involved in doping Players or covering up doping should be subject to sanctions which are more severe than the Players who test positive. Since the authority of sport organisations is generally limited to Ineligibility for accreditation, membership and other sport benefits, reporting Player Support Personnel to competent authorities is an important step in the deterrence of doping.

Comment 29 (Regulation 21.10.3.5): Where the “other Person” referenced in Regulation 21.2.10 (Prohibited Association) is an entity and not an individual, that entity may be disciplined as provided in Regulation 21.12 and/or Regulation 18.

Comment 30 (Regulation 21.10.4): This Regulation and Regulation 21.10.5.2 apply only to the imposition of sanctions; they are not applicable to the determination of whether an anti-doping rule violation has occurred. They will only apply in exceptional circumstances, for example where a Player could prove that, despite all due care, was sabotaged by a competitor. Conversely, No Fault or Negligence would not apply in the following circumstances: (a) a positive test resulting from a mislabelled or contaminated vitamin or nutritional supplement (Players are responsible for what they ingest (Regulation 21.2.1.1) and have been warned against the possibility of

supplement contamination); (b) the Administration of a Prohibited Substance by the Player's personal physician or trainer without disclosure to the Player (Players are responsible for their choice of medical personnel and for advising medical personnel that they cannot be given any Prohibited Substance); and (c) sabotage of the Player's food or drink by a spouse, coach or other Person within the Player's circle of associates (Players are responsible for what they ingest and for the conduct of those Persons to whom they entrust access to their food and drink). However, depending on the unique facts of a particular case, any of the referenced illustrations could result in a reduced sanction under Regulation 21.10.5 based on No Significant Fault or Negligence.

Comment 31 (Regulation 21.10.5.1.2): In assessing that Player's degree of Fault, it would, for example, be favorable for the Player if the Player had declared the product which was subsequently determined to be contaminated on his Doping Control form.

Comment 32 (Regulation 21.10.5.2): Regulation 21.10.5.2 may be applied to any anti-doping rule violation except those Regulations where intent is an element of the anti-doping rule violation (e.g., Regulations 21.2.5 (Tampering or Attempted Tampering), 21.2.7 (Trafficking), 21.2.8 (Administration) or 21.2.9 (Complicity)) or an element of a particular sanction (e.g., Regulation 21.10.2.1 (Use)) or a range of Ineligibility is already provided in a Regulation based on the Player or other Person's degree of Fault.

Comment 33 (Regulation 21.10.6.1): The cooperation of Players, Player Support Personnel and other Persons who acknowledge their mistakes and are willing to bring other anti-doping rule violations to light is important to clean sport. This is the only circumstance under the Code where the suspension of an otherwise applicable period of Ineligibility is authorised.

Comment 34 (Regulation 21.10.6.2): This Regulation is intended to apply when a Player or other Person comes forward and admits to an anti-doping rule violation in circumstances where no Anti-Doping Organisation is aware that an anti-doping rule violation might have been committed. It is not intended to apply to circumstances where the admission occurs after the Player or other Person believes he or she is about to be caught. The amount by which Ineligibility is reduced should be based on the likelihood that the Player or other Person would have been caught had he not come forward voluntarily.

Comment 35 (Regulation 21.10.6.4): The appropriate sanction is determined in a sequence of four steps. First, the hearing panel determines which of the basic sanctions (Regulations 21.10.2, 21.10.3, 21.10.4, or 21.10.5) apply to the particular anti-doping rule violation. Second, if the basic sanction provides for a range of sanctions, the hearing panel must determine the applicable sanction within that range according to the Player or other Person's degree of Fault. In a third step, the hearing panel establishes whether there is a basis for elimination, suspension, or reduction of the sanction (Regulation 21.10.6). Finally, the hearing panel decides on the commencement of the period of Ineligibility under Regulation 21.10.11. Several examples of how Regulation 21.10 is to be applied are found in Appendix 2 to the Code.

Comment 36 (Regulation 21.10.8): Nothing in these Anti-Doping Rules precludes clean Players or other Persons who have been damaged by the actions of a Person

who has committed an anti-doping rule violation from pursuing any right which they would otherwise have to seek damages from such Person.

Comment 37 (Regulation 21.10.11.1): In cases of anti-doping rule violations other than under Regulation 10.2.1, the time required for an Anti-Doping Organisation to discover and develop facts sufficient to establish an anti-doping rule violation may be lengthy, particularly where the Player or other Person has taken affirmative action to avoid detection. In these circumstances, the flexibility provided in this Regulation to start the sanction at an earlier date should not be used.

Comment 38 (Regulation 21.10.11.3.2): A Player's voluntary acceptance of a Provisional Suspension is not an admission by the Player and shall not be used in any way as to draw an adverse inference against the Player.

Comment 39 (Regulation 21.10.11): Regulation 21.10.11 makes clear that delays not attributable to the Player, timely admission by the Player and Provisional Suspension are the only justifications for starting the period of Ineligibility earlier than the date of the final hearing decision.

Comment 40 (Regulation 21.10.12.1): For example, subject to Regulation 21.10.12.2, an Ineligible Player cannot participate in a training camp, exhibition or practice organised by his Member Union or Club, Rugby Body or any entity which is a member of that National Federation or which is funded by a governmental agency. Further, an Ineligible Player may not compete in a non-Signatory professional league (e.g., the National Hockey League, the National Basketball Association, the National Football League etc.), Events organised by a non-Signatory International Event organisation or a non-Signatory national-level event organisation without triggering the Consequences set forth in Regulation 21.10.12.3. The term "activity" also includes, for example, administrative activities, such as serving as an official, director, officer, employee, or volunteer of the organisation described in this Regulation. Ineligibility imposed in one sport shall also be recognised by other sports (see Regulation 21.15.1, Mutual Recognition).

Comment 41 (Regulation 21.10.12.2): In many Team Sports and some individual sports, a Player cannot effectively train on his own so as to be ready to compete at the end of the Player's period of Ineligibility. During the training period described in this Regulation, an Ineligible Player may not compete or engage in any activity described in Regulation 21.10.12.1 other than training.

Comment 42 (Regulation 21.10): Harmonisation of sanctions has been one of the most discussed and debated areas of anti-doping. Harmonisation means that the same rules and criteria are applied to assess the unique facts of each case. Arguments against requiring harmonisation of sanctions are based on differences between sports including, for example, the following: in some sports the Players are professionals making a sizable income from the sport and in others the Players are true amateurs; in those sports where an Player's career is short, a standard period of Ineligibility has a much more significant effect on the Player than in sports where careers are traditionally much longer. A primary argument in favor of harmonisation is that it is simply not right that two Players from the same country who test positive for the same Prohibited Substance under similar circumstances should receive different sanctions only because they participate in different sports. In addition, flexibility in sanctioning has often been viewed as an unacceptable opportunity for some sporting

organisations to be more lenient with dopers. The lack of harmonisation of sanctions has also frequently been the source of jurisdictional conflicts between International Federations and National Anti-Doping Organisations.

Comment 43 (Regulation 21.11.3): For example, the International Olympic Committee could establish rules which would require Disqualification of a team from the Olympic Games based on a lesser number of anti-doping rule violations during the period of the Games.

Comment 44 (Regulation 21.13.1.2): CAS proceedings are de novo. Prior proceedings do not limit the evidence or carry weight in the hearing before CAS.

Comment 45 (Regulation 21.13.1.3): Where a decision has been rendered before the final stage of World Rugby's process (for example, a first hearing) and no party elects to submit that decision to a post-hearing review, then WADA may bypass the remaining steps in World Rugby's internal process and appeal directly to CAS.

Comment 46 (Regulation 21.13.2.1): CAS decisions are final and binding except for any review required by law applicable to the annulment or enforcement of arbitral awards.

Comment 47 (Regulation 21.13.2.4): This provision is necessary because since 2011, CAS rules no longer permit a Player the right to cross appeal when an Anti-Doping Organisation appeals a decision after the Player's time for appeal has expired. This provision permits a full hearing for all parties.

In cases involving multiple parties, where all of the parties identified in this Regulation are satisfied that their interests will be adequately protected in a single hearing, there is no need to incur the extra expense of two (or more) hearings. An Anti-Doping Organisation that wants to participate in the CAS hearing as a party or as an observer may condition its approval of a single hearing on being granted that right.

Comment 48 (Regulation 21.13.3): Given the different circumstances of each anti-doping rule violation investigation and results management process, it is not feasible to establish a fixed time period for World Rugby to render a decision before WADA may intervene by appealing directly to CAS. Before taking such action, however, WADA will consult with World Rugby and give World Rugby an opportunity to explain why it has not yet rendered a decision.

Comment 49 (Regulation 21.15.1): The extent of recognition of TUE decisions of other Anti-Doping Organisations shall be determined by Regulation 21.4.4 and the International Standard for Therapeutic Use Exemptions.

Comment 50 (Regulation 21.15.2): Where the decision of a body that has not accepted the Code is in some respects Code compliant and in other respects not Code compliant, World Rugby and its Member Unions shall attempt to apply the decision in harmony with the principles of the Code. For example, if in a process consistent with the Code a non-Signatory has found a Player to have committed an anti-doping rule violation on account of the presence of a Prohibited Substance in his body but the period of Ineligibility applied is shorter than the period provided for in these Anti-Doping Rules, then World Rugby shall recognise the finding of an anti-doping rule violation and may conduct a hearing consistent with Regulation 21.8 to determine whether the longer period of Ineligibility provided in these Anti-Doping Rules should be imposed.

Comment 51 (Regulation 21.22.1.2): With due regard to a Player's human rights and privacy, legitimate anti-doping considerations sometimes require Sample collection late at night or early in the morning. For example, it is known that some Players use low doses of EPO during these hours so that it will be undetectable in the morning.

Comment 52 (Definition of Fault): The criteria for assessing a Player's degree of Fault is the same under all Regulations where Fault is to be considered. However, under Regulation 21.10.5.2, no reduction of sanction is appropriate unless, when the degree of Fault is assessed, the conclusion is that No Significant Fault or Negligence on the part of the Player or other Person was involved.

Comment 53 (Definition of In-Competition): World Rugby, Tournament Organiser, or ruling body for an Event may establish an "In-Competition" period that is different than the Event Period.

Comment 54 (Definition of International-Level Player): Consistent with the International Standard for Testing and Investigations, World Rugby is free to determine the criteria it will use to classify Players as International-Level Players.

Comment 55 (Definition of No Significant Fault or Negligence): For Cannabinoids, a Player may establish No Significant Fault or Negligence by clearly demonstrating that the context of the Use was unrelated to sport performance.

Comment 56 (Definition of Player): This definition makes it clear that all International- and National-Level Players are subject to the Anti-Doping Rules and the Code. The definition also allows each National Anti-Doping Organisation, if it chooses to do so, to expand its anti-doping program beyond International- or National-Level Players to competitors at lower levels of Competition or to individuals who engage in fitness activities but do not compete at all. Thus, a National Anti-Doping Organisation could, for example, elect to test recreational-level competitors but not require advance TUEs. But an anti-doping rule violation involving an Adverse Analytical Finding or Tampering results in all of the Consequences provided for in the Code (with the exception of Regulation 21.14.3.2). The decision on whether Consequences apply to recreational-level Players who engage in fitness activities but never compete is left to the National Anti-Doping Organisation. In the same manner, a Major Event Organisation holding an Event only for masters-level competitors could elect to test the competitors but not analyse Samples for the full menu of Prohibited Substances. Competitors at all levels of Competition should receive the benefit of anti-doping information and education.

Comment 57 (Definition of Possession): Under this definition, steroids found in a Player's car would constitute a violation unless the Player establishes that someone else used the car; in that event, the Anti-Doping Organisation must establish that, even though the Player did not have exclusive control over the car, the Player knew about the steroids and intended to have control over the steroids. Similarly, in the example of steroids found in a home medicine cabinet under the joint control of a Player and spouse, the Anti-Doping Organisation must establish that the Player knew the steroids were in the cabinet and that the Player intended to exercise control over the steroids. The act of purchasing a Prohibited Substance alone constitutes Possession, even where, for example, the product does not arrive, is received by someone else, or is sent to a third party address.

Comment 58 (Definition of Provisional Hearing): A Provisional Hearing is only a preliminary proceeding which may not involve a full review of the facts of the case. Following a Provisional Hearing, the Player remains entitled to a subsequent full hearing on the merits of the case. By contrast, an “expedited hearing,” as that term is used in Regulation 21.8.1, is a full hearing on the merits conducted on an expedited time schedule.

Comment 59 (Definition of Sample or Specimen): It has sometimes been claimed that the collection of blood Samples violates the tenets of certain religious or cultural groups. It has been determined that there is no basis for any such claim.

Comment 60 (to Definitions): Defined terms shall include their plural and possessive forms, as well as those terms used as other parts of speech.

---

**SCHEDULE 1. DOPING CONTROL PROCEDURAL GUIDELINES****1. Doping Control Procedural Guidelines (“Guidelines”)**

- (a) These Guidelines are in compliance with the WADA International Standard for Testing and Investigations should be followed as far as is reasonably practicable. However, any departure from the procedures set out in these Guidelines shall not invalidate a finding of an anti-doping rule violation unless such departure undermines the validity of such finding.

**2. Doping Control Station**

- (a) For In Competition Doping Control the Union or Tournament Organiser hosting the Match/Tournament shall provide a Doping Control Station.
- (i) The Doping Control Station shall be secure and comprise of a waiting room, a processing area and a toilet (WC). The processing area shall be separate to the waiting area and should be private. The toilet should also be within the Doping Control Station.
- (ii) The Doping Control Station shall not be shared with any other functional area supporting the Game.
- (iii) The Doping Control Station shall be furnished to enable Sample collection to be carried out. This is the responsibility of the Host Union or Tournament Organiser.
- (iv) The Doping Control Officer (DCO), World Rugby or the Tournament Organiser (as the case may be) shall provide the Sample collection equipment necessary to conduct the Doping Control session.
- (v) Security shall be provided on the entrance to the Doping Control Station or the DCO shall require a set of keys to the Doping Control Station for the duration of the Testing session.
- (vi) No media, photography, video or recordings of any sort are permitted in the Doping Control Station while the station is in operation.
- (vii) A range of sealed, chilled non-alcoholic drinks should be available in the waiting area of the Doping Control Station to allow Players to hydrate. These drinks should also be offered to the selected Players at the time of notification.
- (viii) The Host Union/Tournament Organiser shall be responsible for ensuring that the Doping Control Station is clearly identified; that the facilities are secure and clean and that the necessary furniture and fit out of the area in which Testing will take place has been provided and is acceptable. The DCO/Anti-Doping

Commissioner (if present) shall review this on their arrival at the Doping Control Station.

### **3. Authorised Doping Control Officials**

- (a) For In Competition Testing at a Match, a Sample collection Team should at a minimum consist of one DCO and four Chaperones. If additional selections or multiple Matches are taking place then a suitable number of DCOs and Chaperones should be appointed.
- (b) Chaperones must be of the same gender as those Players being tested and must be over the age of twenty one.
- (c) The DCO and the Chaperones shall carry an identification card and/or a letter authorising them to act as authorised Doping Control officials and confirming their entitlement to collect Samples from Players. Such identification should be made available to a Player when that Player is notified of his selection for a test. Chaperones are at a minimum required to carry a letter of authorisation.
- (d) The DCO, Chaperones and any Anti-Doping Commissioner shall be issued with Tournament or Match accreditation (where existing) that will grant them access to the venue(s), training grounds and to areas within the venue(s) and training grounds in which they may require access to in order to carry out their duties.
- (e) A DCO, Chaperone or Anti-Doping Commissioner who may have an interest in the outcome of the collection or Testing of a Sample from any Player who might provide a Sample at a Testing session shall not be appointed to the notification, Sample collection or Sample processing of that Player. Sample collection staff are deemed to have an interest in the collection of a Sample if they are:
  - (i) Involved in the planning of the Game; or
  - (ii) Related to, or involved in the personal affairs of, any Player who might provide a Sample at that session.
- (f) All Sample collection staff shall have undertaken suitable training in relation to their role and activities of their position.
- (g) DCOs may personally perform any activities involved in the Sample collection session, with the exception of blood collection unless qualified and registered with the appropriate medical authority and appropriately experienced.

### **4. Selection of Players In Competition**

- (a) The selection of Players for In Competition Testing may be random or targeted.



### Random Selection

- (b) Using the numbered-card system or equivalent. The selection process should, ordinarily, take place within a one (1) hour time period prior to the commencement of the Match
- (c) The random selection draw of Players will take place in the Doping Control Station or in a private location.
- (d) The DCO will arrange for the random draw to be made by the two Team managers or their delegated representatives. The Anti-Doping Commissioner may also be present.
- (e) The DCO shall provide a set of cards for each Team numbered from 1 to the number corresponding to the total number of Players and replacements/substitutes participating in the Match or Tournament as appearing on the official Team sheet/Match list.
- (f) Each set of cards shall then be rearranged or shuffled and placed down as to expose only the reverse side, which does not show any number. Each Team manager shall select four cards of their own choice. On each card the Team manager shall sign and record the name of their Team. The selected cards shall be left face down so the numbers of the selected Players remains confidential.
- (g) Each Team manager shall also mark two of the four cards selected with “R1” and “R2” in addition to the Team manager’s signature and the name of their Team. These “reserve” cards may be used in the case of a selected Player being seriously injured and requiring immediate hospitalisation. For the avoidance of doubt if a selected Player is injured or is replaced for any reason prior to the start of a Match they shall remain selected for Testing unless they require immediate hospitalisation. If the Player does require immediate hospitalisation then one of the reserve selections shall be used.
- (h) At no stage are the selections, whether random or targeted, to be made known to the Team manager or any other party outside of the authorised Sample collection Team until the end of the Match. If the Team manager or his delegated representative wish to see the random selection cards drawn for their Team the Anti-Doping Commissioner or DCO shall show them the selected cards post Match.

### Target Selection

- (i) World Rugby, a Host Union, Tournament Organiser or DCO shall have the right to request, without justifying the reason, that any Player undergo Testing at any time during a World Rugby Tournament or designated event. This may be a target selection of a Player(s) rather than using the random selection process or may be in addition to any random selection(s) made. Such target selections may also be specific to one or more Team(s). No reason is required to be provided by World Rugby, a Host Union, Tournament

Organiser or DCO justifying why Target Testing is occurring for a Player(s). However, the Team manager shall ordinarily be notified by the DCO or the Anti-Doping Commissioner prior to the end of the Match that Target Testing is occurring but the identity of the targeted Players will not be advised until the end of the Match.

- (j) A Player may be subject to Doping Control on more than one occasion during any World Rugby Tournament or designated event or Tournament Organiser event.
- (k) Where a Player selected to undertake Doping Control is certified by the Match doctor to have been so seriously injured during the Match as to require hospitalisation, then that Team's reserve "R" Player selected at the time of the random draw shall undertake the drug test in place of the originally selected Player.
- (l) The Match doctor shall provide a brief written report to the DCO outlining the reasons for Players hospitalisation and his inability to provide a Sample for Doping Control.

### **5. Notification of Selection In Competition**

- (a) The Chaperone shall be advised of their selected Player from when the Match begins. The DCO and Chaperones should be located in a position within the Match venue where they have good vision of the selected Players during the Match.
- (b) As soon as reasonably practicable after the conclusion of the Match and in a discreet manner the Chaperones shall identify the selected Players and notify them individually that they are required to submit to Doping Control. All tests are to be conducted as No Advance Notice subject to (c) below.
- (c) The DCO or Chaperone shall consider whether a third party is required to be notified prior to the notification of the Player for example when the Player is a Minor or in situations where an interpreter is required for notification or when assistance from a third party is required to identify the selected Player.
- (d) A Player selected for Doping Control shall be handed a Doping Control form by a Chaperone confirming that the Player is required to submit to Doping Control. The Player shall acknowledge and accept notification of their selection by signing the Doping Control form as soon as the Player has read the Doping Control form.
- (e) The Chaperone shall record the time of notification.
- (f) A Chaperone shall accompany the Player selected from the time of notification until such time as the Player is handed over to the DCO in the processing area of the Doping Control Station. A Chaperone shall keep the Player under continuous, direct supervision.

- (g) Players should attend the Doping Control Station as soon as possible following notification that they have been selected for Doping Control. In any event, the Player shall arrive at the Doping Control Station as soon as they have completed their post Match activities which may consist of any activities as outlined in section 6(b) in this Schedule which must be completed within one (1) hour of being notified. The time of arrival to the Doping Control Station should be recorded by the Chaperone or DCO on the Doping Control form.
- (h) If an In Competition session cannot be completed after a Match (see definition of In Competition) the formal notification to the Player of the extension of the In Competition period up to a maximum of 24 hours shall be made in the comments section of the Doping Control form or on a supplementary form. The Doping Control Officer shall agree a time and place for Sample collection from the Player during the subsequent 24-hour period and shall record such time and place in the comments section of the Doping Control form or on a supplementary form. The Player shall acknowledge such notification and agreement by signing the appropriate form. Failure to appear for Sample collection at the agreed time and place shall constitute a breach of Regulation 21.2.3.

## **6. Players Rights and Responsibilities**

- (a) The Player has the right to:
  - (i) Have a representative and if available an interpreter present in the Doping Control Station (except for when the Player is passing a urine Sample);
  - (ii) Request additional information about the Sample collection process;
  - (iii) Request a delay in reporting to the Doping Control Station for valid reasons which may result in the Player arriving after the initial one hour period has expired. The DCO and/or Anti-Doping Commissioner shall decide on whether to approve such request.
- (b) Under the direct supervision of a Chaperone and within one (1) hour of notification a Player may complete any of the following before arriving to the Doping Control Station:
  - (i) Attend a victory ceremony;
  - (ii) Fulfill media commitments;
  - (iii) Perform a warm-down or take an ice bath;
  - (iv) Be medically assessed and receive any necessary medical attention either in the Team change room or Match medical room;

## SCHEDULE 1

---

- (v) Attend a post-Match Team meeting in the Team change room;
  - (vi) Change out of his playing uniform;
  - (vii) Locate a representative and/or interpreter;
  - (viii) Obtain the relevant personal identification;
  - (ix) Complete a training session if selected for Out of Competition Testing;
  - (x) Any other exceptional circumstances which may be justified, and which shall be documented. These may include but are not limited to the following:
    - A Player shall be permitted to take a shower for health and welfare reasons, for example due to the Player bleeding or having sustained any type of injury in which a shower would assist in the treatment of the injury or where due to the playing or training conditions the Player is cold and wet.
    - If a Player takes a shower due to the above reasons then it should be documented accordingly on the Doping Control form and the DCO/Chaperone shall inform the Player that he shall be under the direct observation of the DCO/Chaperone and shall not be permitted to pass urine in the shower or otherwise prior to providing a Sample in the Doping Control Station. Failure by the Player to adhere to this instruction may result in additional Samples being requested from the Player.
- (c) Once a Player has arrived at the Doping Control Station he shall be expected to remain until the Sample collection, Sample division and sealing procedures have been concluded and the relevant documentation completed.
- (d) The Anti-Doping Commissioner or in the event there is no Anti-Doping Commissioner present the DCO may grant permission for the Player to leave the Doping Control Station temporarily after arrival to perform one of the above activities listed in (b) but only if the Player;
- (i) Identifies the purpose of their request to leave the Doping Control Station;
  - (ii) Returns to the Doping Control Station within the specified time allocated;
  - (iii) Is continuously chaperoned and kept under direct observation during any temporary permitted departure from the Doping Control Station; and
  - (iv) Does not urinate during this permitted absence period.

- (e) Where Team meetings occur within the one (1) hour notification period that require the presence of the selected Players, it shall be a requirement that each Player's Chaperone is present at the Team meeting to ensure the selected Players are kept under direct observation. Any Person who restricts the DCO or Chaperone from gaining entry to the Team changing room or meeting room to notify or escort a selected Player for the purposes of Doping Control may be in breach of these Regulations and shall be subject to disciplinary action.
- (f) It is a Player's responsibility to ensure that:
- (i) He is aware of and complies with these Anti-Doping Rules;
  - (ii) He remains within direct observation of the DCO/Chaperone at all times from the point of notification by the DCO/Chaperone until the completion of the Sample collection procedure;
  - (iii) He complies with the notification, Sample collection and sealing procedures;
  - (iv) The Sample he provides shall be the first Sample passed post-notification. The Player shall not pass urine in the shower or otherwise prior to providing a Sample in the Doping Control Station;
  - (v) He is aware that any food or fluids consumed prior to providing the Sample is done at the Player's own risk. The Player should avoid excessive hydration as this may have implications to the suitability of their Sample or the laboratory and may require him to provide an additional Sample(s) until the urine is within the required range of the laboratory;
  - (vi) He produces identification to identify himself. This may be by way of photo, third party or other appropriate means accepted by the DCO. In cases where the Player's identity cannot be confirmed World Rugby, the Union, Tournament Organiser and or the DCO shall decide whether it is appropriate to follow up a possible failure to comply;
  - (vii) He arrives at the Doping Control Station within one (1) hour of notification to provide his Sample. If the Player delays reporting to the Doping Control Station and arrives later than one (1) hour from the time of notification the Chaperone/DCO accompanying the Player, or avoids or attempts to avoid being kept under direct supervision of the Chaperone, the DCO shall document the reasons for the delay and any circumstances regarding the Players behaviour while being chaperoned. The DCO shall proceed to collect a Sample from the Player and may require an additional Sample to be provided by the Player or may file a potential breach of Regulation 21.2.5 based on the circumstances;

- (viii) He controls the Sample until it is sealed in the urine Sample collection kit save where he gives his representative or the DCO approval to carry out the division and sealing process;
- (ix) The sealed urine Sample collection kit is secure and the Sample kit/bottle numbers are identified correctly on the Doping Control form;
- (x) He receives a copy of the notification and/or the Doping Control form.

**7. Testing of Minors**

- (a) Players who are Minors may be accompanied by a representative throughout the entire Sample collection session. The Player's representative shall not witness the passing of a urine Sample unless requested to do so by the Minor. The objective is to ensure that the DCO is observing the Sample provision correctly. Even if the Minor declines a representative the DCO/Anti-Doping Commissioner shall consider whether a third party should be present during notification and/or the collection of the Sample from the Player.
- (b) Should a Minor decline to have a representative present during the Sample collection session, this should be clearly documented by the DCO on the Doping Control form. Such decline does not invalidate the test. If a Minor declines the presence of a representative, a representative of the Sample collection Team in addition to the DCO must be present.
- (c) Should a Minor be subject to Out of Competition Testing, the preferred venue for Testing to take place is a location where the presence of an adult is most likely, e.g. training venue or Player's place of residence.
- (d) If no adult is present at the Testing of a Player Out of Competition who is a Minor, the DCO shall accommodate the Player by locating a representative in order to proceed with Testing.

**8. Failure to Comply With a Request for Doping Control**

- (a) If a Player refuses to sign the notification/Doping Control form confirming that he has been notified, and/or evades the notification and/or refuses to report to the Doping Control Station after notification, the Chaperone/DCO shall use his best endeavours to inform the Player of the consequences of refusing or failing to comply. If the Player still refuses after being advised of the consequences, the Chaperone should then immediately report this to the DCO/Anti-Doping Commissioner who shall use his best endeavours to further inform the Player of his obligation to submit to Doping Control and attempt to collect a Sample.
- (b) If the Player still fails or refuses to sign the notification form and/or fails to report to the Doping Control Station he shall be deemed to

have failed or refused to submit to Doping Control and to have thereby committed an anti-doping rule violation.

- (c) The Chaperone shall note this on the notification or Doping Control form and sign it. The DCO will provide a written report on the actions involving the Players refusal or failure to comply. Such report and accompanying documents shall be forwarded to World Rugby, the Union, and/or Tournament Organiser as soon as possible.
- (d) World Rugby, the Union or Tournament Organiser shall conduct an investigation into the alleged failure to comply in accordance with Regulation 21.6.6.

## **9. Arrival at the Doping Control Station**

- (a) Only the following persons shall be authorised to attend the Doping Control Station:
  - (i) The Players selected for Testing;
  - (ii) The Player's representative, if any;
  - (iii) The Players interpreter (if appropriate);
  - (iv) The Doping Control Officer;
  - (v) The Chaperones;
  - (vi) The Anti-Doping Commissioner; and
  - (vii) WADA Independent Observer.
- (b) The Player may consume fluids provided in the Doping Control Station which shall be sealed.

## **10. Sample Collection Equipment**

- (a) Only Sample collection equipment systems which, at a minimum, meet the following criteria shall be utilised. Such equipment shall:
  - (i) Have a unique numbering system incorporated into all bottles, containers, tubes or other items used to seal the Sample;
  - (ii) Have a sealing system that is tamper evident;
  - (iii) Ensure the identity of the Player is not evident from the equipment itself; and
  - (iv) Is clean and sealed prior to use by the Player.

## **11. Providing a Urine Sample**

- (a) The Player shall be requested to provide a minimum urine Sample of 90ml however the Player should be urged to provide a greater amount if possible.

- (b) When the Player believes that he is ready to provide a urine Sample he shall move from the waiting area to the processing area of the Doping Control Station. The DCO shall ensure that the Player is informed of the requirements of Sample collection. The Player shall be offered a choice of Sample Collection equipment. The DCO shall instruct the Player to select a sealed Sample collection vessel from a minimum of two. The Player should break the seal of the Sample collection vessel, remove and check that the vessel is clean. If the Player is not satisfied with the Sample collection vessel he may select another. If the Player is not satisfied with any of the Sample collection vessels available for selection, this shall be recorded by the DCO.

If the DCO does not agree with the Player that all of the Sample collection vessels are unsatisfactory, the DCO shall instruct the Player to proceed with the Sample collection session.

If the DCO agrees with the Player that all of the Sample collection vessels available for the selection are unsatisfactory, the DCO shall terminate the collection of the Player's urine Sample and this shall be recorded by the DCO.

The Player and the DCO shall then proceed to the toilet area. The Chaperone shall remain in the processing area with the Player's representative and/or interpreter or the Player's representative and/or interpreter shall be asked to return to the waiting room until the Player has provided his Sample if a second Sample collection Team member is not present.

- (c) No one other than the DCO and the Player shall be present in the toilet when the urine is being provided by the Player.
- (d) To ensure authenticity of the Sample, the Player shall be required to remove such items of clothing as is necessary to allow the DCO an unobstructed view of the Player urinating into the collection vessel. The DCO shall record the witnessing of the Sample in writing on the Doping Control form.
- (e) The DCO who witnesses the passing of the Sample shall be of the same gender as the Player providing the Sample.
- (f) The DCO/Chaperone should where practicable ensure that the Player thoroughly washes his hands or if hand-washing facilities do not exist is provided with surgical gloves prior to the provision of a Sample.
- (g) When the Player signifies to the DCO that he has finished providing his Sample, the Player and the DCO shall return to the processing area. The Player shall keep control of the Sample at all times until the Sample is sealed. The DCO shall keep the collection vessel in sight at all times. Additional assistance may be provided in exceptional circumstances to any Player by the Player's



representative or DCO during the Sample collection session where authorised by the Player and agreed to by the DCO/Anti-Doping Commissioner.

- (h) Any behaviour by the Player and/or persons associated with the Player or anomalies with the potential to compromise the Sample collection shall be recorded in detail by the DCO. If appropriate World Rugby, the Union or Tournament Organiser shall institute the investigation of a possible failure to comply or Tampering or Attempted Tampering with any part of Doping Control.
- (i) If there are doubts as to the origin or authenticity of the Sample, the Player shall be asked to provide an additional Sample, the DCO shall document in detail the circumstances around the refusal, and World Rugby, the Union or Tournament Organiser shall institute a possible failure to comply.

## **12. Division and Sealing the Urine Sample**

- (a) Upon returning to the processing area, the quantity of urine shall be measured by the DCO. If the quantity of urine is less than 90ml the partial Sample procedure set out in section 18 of this Schedule 1 shall apply.
- (b) If the collection vessel contains approximately 90ml or more of urine, the Player shall select a sealed urine Sample kit from a minimum of two. The Player should check the security of the kit prior to opening it. If there is any evidence of tampering the Player should select a new urine Sample kit. The Player will then be invited to break the security seal and remove the contents of the kit.
- (c) The following procedures must be carried out in the presence of the Player and the Player's Representative, if any, and the DCO. The Player may request that the DCO carry out the Sample division and sealing procedures. If this is the case, the DCO shall note this on the Doping Control form in the comments section.
- (d) The urine Sample kit should contain two clean bottles. One bottle shall be marked Sample "A" and one bottle Sample "B" and will contain corresponding code numbers. The Player and his representative, if any, should check that the Sample bottle codes correspond. The Sample bottle codes should also correspond to the external code number on the urine Sample kit. If either does not correspond then a new urine Sample kit should be selected. The DCO shall record the Sample number on the Doping Control form if the numbers correspond.
- (e) The Player's Sample shall then be divided between the "A" and the "B" Sample bottles. It is recommended that the "A" Sample contain approximately two thirds of the urine (a minimum of 60ml) provided and the "B" Sample contain the remaining third (a minimum of 30ml). If a large volume of urine is provided then each bottle shall be filled

up to the maximum level permitted in each bottle. However, any shortfall in the amount of urine in either bottle after division shall not invalidate a test provided there is sufficient urine for the analysis to be adequately performed.

- (f) The DCO shall instruct the Player to leave a small amount of urine in the collection vessel so that the specific gravity of the Sample can be measured in accordance with section 13.
- (g) Both the “A” and “B” bottles shall be tightly sealed by the Player. The DCO shall check in full view of the Player that the “A” and “B” bottles have been properly sealed and there is no leakage.

### **13. Specific Gravity Test**

- (a) The DCO shall test the residual urine in the collection vessel to determine if the Sample has suitable specific gravity for analysis. The specific gravity is a measure of how concentrated or dilute the Sample is.
- (b) The DCO shall measure the specific gravity of a Player’s urine using the residual volume of the urine remaining in the collection vessel after the Sample has been sealed.
- (c) The specific gravity criteria for acceptance of the Sample shall be as follows:
  - (i) not less than 1.010 - if using urine analysis strips;
  - (ii) not less than 1.005 - if using a refractometer.
- (d) If the Sample does not meet the required specifications the DCO shall inform the Player that he is required to provide a further Sample.
- (e) The Player shall remain under continuous observation while waiting to provide additional Sample(s).
- (f) The Player shall not hydrate any further as this will cause dilution which will continue to delay the production of a suitable Sample. A failure to adhere to this instruction may result in the DCO reporting attempts of Tampering with the Doping Control process.
- (g) When the Player is able to provide an additional Sample, the DCO shall repeat the procedures for collection of the Sample as outlined in section 11 of this Schedule.
- (h) The DCO should continue to collect additional Samples until the requirement for suitable specific gravity for analysis is met, or until the Anti-Doping Commissioner or DCO determines that there are exceptional circumstances which mean that for logistical reasons it is impossible to continue with the Sample collection session. Such exceptional circumstances shall be documented accordingly by the Anti-Doping Commissioner or DCO.

- (i) If a Player has been in the Doping Control Station for five or more hours after providing an unsuitable Sample(s), has not consumed any further liquids, has provided additional Samples but is yet to produce a suitable Sample then the DCO or Anti-Doping Commissioner may cancel the Sample collection session. If the DCO or Anti-Doping Commissioner cancels the Sample collection session then they should consider either rescheduling the test for the following day if logistically possible or target test the Player at a later date. Where the DCO or Anti-Doping Commissioner reschedules the test for the following day this should be on an In Competition basis in accordance with the procedure set out at section 5(h) in this Schedule.
- (j) The DCO shall record that the Samples collected belongs to a single Player and the order in which the Samples were provided.
- (k) If it is determined that none of the Player's Samples meets the specific gravity requirements for analysis and the DCO determines that for logistical reasons it is impossible to continue with the Sample collection session, the DCO may end the Sample collection session. In such circumstances, if appropriate the ADO may also investigate a possible anti-doping rule violation.
- (l) The DCO shall send to the laboratory for analysis all Samples which were collected, irrespective of whether or not they meet the specific gravity requirements and discuss with the laboratory the number of Samples to be analysed.
- (m) If the Player refuses to provide a further Sample(s) he should be notified that such refusal may constitute an anti-doping rule violation.

#### **14. Residual Urine**

The DCO shall ensure that the Player has been given the option of requiring that any residual urine that will not be sent for analysis is discarded in full view of the Player.

#### **15. Research of Urine Post Analysis by Laboratory**

- (a) Prior to any research being conducted on any remaining urine once the analysis process has been completed by the laboratory the following conditions must have been met:
  - (i) The Player has given his consent for any such research to take place (such consent shall be recorded on the laboratory section of the Doping Control form) on his remaining urine once all laboratory procedures have been completed;
  - (ii) The mandatory storage time at the laboratory has expired and;
  - (iii) The removal of any identity code(s) in relation to the Sample.

**16. Declaration of Medication or Other Substances**

- (a) The Player shall be asked by the DCO to declare any medications or any other substance the Player has taken during the previous seven days. This declaration should be recorded on the Doping Control form by the DCO (unless the declaration is not in a language the DCO speaks in which case it shall be recorded in the Player's language by the Player or his representative).
- (b) If the Player declares more medications than the Doping Control form has space for the DCO shall record the remainder of the medications on a supplementary form and attach it to the first Doping Control form. If the Player declines to make such a declaration this should also be recorded on the Doping Control form.
- (c) The DCO shall provide the Player with the opportunity to document any concerns he may have about the way in which the Sample collection procedures were conducted. Any such comments should be recorded on the Doping Control form by the DCO or the Player. If there is insufficient space the Player may document his comment on a supplementary form which he shall sign and date. The DCO shall provide a copy of the Player's additional comments made on the supplementary form to the Player and shall attach the original to the Doping Control form.

**17. Signing Off the Doping Control Form**

- (a) The DCO shall ask the Player and his representative if any, to check all the information on the Doping Control form (and any supplementary form) and if satisfied both the Player and his representative, if any, should sign the form. If the Player indicates his satisfaction with the Sample collection procedures on the Doping Control form this shall amount to conclusive evidence that such procedures were conducted properly.
- (b) The DCO shall then check and sign the Doping Control form noting any irregularities or comments that he may have on the form.
- (c) The DCO shall then provide a copy of the completed Doping Control form to the Player who is then free to leave the Doping Control Station.

**18. Partial Sample**

- (a) If insufficient urine has been provided by a Player i.e. less than 90ml, the Player's Sample will be securely stored temporarily in a partial Sample kit by the DCO until such time as he provides further urine to meet the minimum requirements.
- (b) On returning from the toilet to the processing area the DCO shall instruct the Player to select a partial Sample kit from a minimum of two. The Player should check the security of the kit prior to opening

it. If there is any evidence of tampering the Player should select a new partial Sample kit.

- (c) The Player shall then open the partial kit and check that the bottle is clean before pouring the urine from the collection vessel into the partial Sample kit bottle. The Player shall then close the bottle and seal it as directed by the DCO. The DCO shall then check in full view of the Player that the container has been properly sealed and check that there is no leakage.
- (d) The identity of the insufficient Sample shall be recorded on the Doping Control form along with the time of Sample collection, volume of urine and the Player's signature.
- (e) The Doping Control form and partial Sample shall be kept secure by the DCO until the Player is ready to provide another Sample. The Player shall return to the waiting area and remain under continuous observation by a Chaperone/DCO pending provision of his further Sample. The Player shall be given the opportunity to hydrate.
- (f) When the Player is ready to provide more urine, a new sealed collection vessel should be selected by the Player. The Player shall be advised of the amount of urine required to meet the minimum 90ml level. The Player should again provide his Sample in accordance with section 11 of this Schedule.
- (g) When the DCO is satisfied that the minimum volume have been met and before removing the seal to open the sealed partial Sample, the DCO and the Player should check the code number of the partial kit/bottle in which the Player's partial Sample is stored against the code number recorded on the Doping Control form. The Player and DCO shall ensure that the seal has not been tampered with. Any irregularity with the integrity of the seal/s will be recorded by the DCO and investigated if required.
- (h) The DCO shall then direct the Player to break the seal and combine the urine collected from the Player in the previous collection and add this urine to the subsequent collection in the collection vessel. The total volume shall be checked by the DCO to determine if the minimum requirements have been met. If the Sample is still insufficient in volume, the partial Sample sealing and recording procedures shall be repeated.
- (i) Once a combined urine volume of 90ml has been provided the standard division and sealing procedures should be followed as set out in section 12 of this Schedule.

## **19. Transportation of Samples to the Laboratory**

- (a) The sealed Samples should be securely stored pending their dispatch to a WADA accredited laboratory (or as otherwise approved by WADA) for analysis.

- (b) All Samples shall be sent by a courier (to ensure that the Samples and related documentation will be transported in a manner that protects the integrity, identity and security of the shipment). Samples shall always be transported to the WADA accredited laboratory (or as otherwise approved by WADA), as soon as reasonably practicable after the completion of the Sample collection session.
- (c) Samples shall be transported in a manner which minimises the potential for Sample degradation due to factors such as time delays and extreme temperature variations. Refrigeration or freezing of Samples may be required prior to transport by the courier if the Samples were collected in a country that does not have regular courier services or if the laboratory where the Samples are to be analysed is a great distance away from the point of dispatch.
- (d) All Samples forwarded to WADA accredited laboratories (or as otherwise approved by WADA) shall be placed in suitable transport containers or bags. Copies of each Player's Doping Control form, which shall only contain details of the Sample code, declared medications and other relevant information for the laboratory and which does not reveal the identity of the Player shall accompany the Samples to the laboratory.
- (e) A summary of all Sample codes collected shall be recorded on the relevant document and shall also be forwarded to the WADA accredited laboratory (or as otherwise approved by WADA) with the sealed Samples.
- (f) If sending the Samples to a WADA accredited laboratory (or as otherwise approved by WADA) outside of the country of where the Samples were collected a customs declaration may be required to accompany the Samples.

### **20. WADA Accredited Laboratory**

- (a) World Rugby, the Union or Tournament Organiser shall ensure that the WADA accredited laboratory (or as otherwise approved by WADA) where the Samples are being analysed confirms receipt of the Samples sent, that the Samples delivered correspond with the accompanying paperwork and that there is no evidence of any tampering of the Samples. If there is any evidence of tampering then World Rugby, the Union or Tournament Organiser shall consider whether the Sample shall be voided.
- (b) The WADA accredited laboratory (or as otherwise approved) shall proceed to analyse the "A" Sample for Prohibited Substances as per the current WADA Prohibited List

### **21. Result Management**

- (a) If the "A" Sample returns a negative result then the WADA accredited laboratory (or as otherwise approved by WADA) shall report this to World Rugby, the Union or Tournament Organiser (as

the case may be). World Rugby, the Union and/or Tournament Organiser shall then notify the Player's Union of the result. The Union should then notify the Player of this result.

- (b) If the "A" Sample returns an Adverse Analytical Finding then the procedures set out in World Rugby Regulation 21.7 shall apply.
- (c) In line with the WADA International Standard for Laboratories World Rugby shall be notified of all Adverse Analytical Findings for the sport of rugby union regardless of whether World Rugby coordinated the Testing.

## **22. Out of Competition Testing**

- (a) Under World Rugby's Out of Competition programme World Rugby may select any Player under membership of a Union to undergo Testing at any time or place regardless of whether that Player is part of a Registered Testing Pool or Testing Pool.
- (b) World Rugby may appoint a Sample collection agency to conduct Out of Competition Testing on behalf of World Rugby.
- (c) Such Testing shall where possible be conducted with No Advance Notice by an authorised Doping Control Official.
- (d) Out of Competition Testing may take place during a rugby season or out-of-season and may occur at a training ground, residential accommodation or any other place where the Player is likely to be found and/or has indicated in his Whereabouts Filing.

## **23. Selection of Players Out of Competition**

- (a) A Player may be selected for Out of Competition testing by either random selection or targeted by World Rugby, Member Union, Tournament Organiser or other authorised Anti-Doping Organisation.

## **24. Notification of Players Out of Competition**

- (a) A Player shall be notified for Out of Competition Doping Control by "No Advance Notice" notification, where the DCO or Chaperone appears unannounced and notifies the selected Player in person. The selected Player is then kept under direct observation until the Sample is sealed and appropriate documentation completed. Advance notice notification, shall only occur in the most exceptional circumstances.
- (b) Where a DCO appointed by World Rugby to conduct No Advance Notice Out of Competition Doping Control, the DCO or Chaperone should give the Player a reasonable time to complete any activity in which he is engaged subject to the DCO's authorisation and agreed time period. Such activity should be within the DCO/ Chaperones clear and continuous view.

- (c) No Advance Notice Doping Control should commence as soon as reasonably practicable after a Player has been notified. In the case where the selected Player is participating in a Team training session, the Player may complete the session under direct view of a DCO or Chaperone before presenting for Doping Control.
- (d) The DCO shall unless advised otherwise attempt to notify the Player(s) selected for Doping Control at all their nominated whereabouts locations (prior to visiting the one hour location if the Player is in a Registered Testing Pool or during the off season or periods of injury if the Player is in the Testing Pool) in an attempt to collect a Sample. If the Player is not present at any of the nominated whereabouts locations the DCO shall attempt to discover in a reasonable and discreet manner the location of the Player without alerting the Player.
- The DCO shall stay at all locations other than the one hour location for a reasonable amount of time but no less than 30 minutes (unless reliable intelligence indicates an alternative location for the Player at that time). The DCO shall stay at the one hour location from the time of arrival until the expiry of the one hour period.
  - If the DCO is unable to locate the Player after visiting all nominated whereabouts locations and any other location that may have been obtained from reliable intelligence in the process of attempting to locate the Player then the DCO shall complete an Unsuccessful Attempt Report.
  - If the DCO is unable to locate the Player at the nominated or default one-hour location then he shall complete an Unsuccessful Attempt Report.
- (e) When a DCO makes contact with the Player who is subject to Out of Competition Doping Control he should show the Player at a minimum:
- (i) A valid form of photo identification; and
  - (ii) A letter from World Rugby, the Union, Tournament Organiser containing the name(s) of the DCO and authorising the DCO(s) to conduct Doping Control on its behalf.
- (f) When a Chaperone makes contact with the Player who is subject to Out of Competition Doping Control he should show the Player at a minimum:
- (i) A letter from World Rugby, the Union or Tournament Organiser authorising the Chaperone to assist with conducting Doping Control on its behalf.
- (g) Prior to undertaking the Sample collection the DCO shall request the Player to produce photo identification or satisfy himself of the identity



of the Player to be tested as further outlined in section 6(f)(vi) of this Schedule.

- (h) The DCO shall make every effort to collect the urine Samples as discreetly as possible and with maximum privacy.
- (i) If the Doping Control facilities are not suitable at the location where notification took place the DCO may conduct Doping Control on the selected Player at another location. The DCO will make this decision. The Player may not leave the location where notification occurred unless the DCO permits. The Player must be accompanied by the DCO or Chaperone at all times if the testing session is to be relocated.
- (j) If the Player wishes to leave the location against the DCO's direction the DCO shall inform the Player that he is required to provide a Sample for Out of Competition Testing at the current location and outline the possible consequences of not complying with a request to provide a Sample and that it may constitute an anti-doping rule violation in accordance with these Anti-Doping Rules. If the Player still does not comply, then a failure to comply shall be recorded. The DCO shall compile a written report relating to the circumstances of the failure to comply.
- (k) In all other respects the Sample collection process shall, as far as reasonably practicable, take place in accordance with the Doping Control Procedural Guidelines for In Competition testing.

## **25. Collection of Blood Samples**

- (a) Blood sampling may be performed prior to, after or separately to any required urine Sample collection procedure in either In Competition or Out of Competition.
- (b) The DCO shall ensure that the Player is informed of the requirements for blood Sample collection.
- (c) The DCO/Chaperone and the Player shall proceed to the area where the Sample will be provided.
- (d) The DCO or Blood Collection Official shall ensure the Player is offered as comfortable conditions as possible including being in a relaxed position for at least ten minutes prior to providing a Sample.
- (e) The DCO shall instruct the Player to choose a blood sampling kit from a selection of at least two sealed kits. Blood sampling kits shall consist of either an "A" Sample tube, or an "A" Sample tube and a "B" Sample tube (if the Sample consists solely of blood, then a "B" Sample shall be collected and used as a confirmation, if required). The DCO will instruct the Player to check that all the seals on the selected equipment are intact and that the equipment has not been tampered with. If the Player is not satisfied with a selected kit, the Player may select another. If the Player is not satisfied with any of

the equipment available for selection, this fact shall be recorded by the DCO. If the DCO does not agree with the Player's opinion that all the equipment available for selection is unsatisfactory, the DCO shall instruct the Player to proceed with the Sample collection session. If the DCO agrees with the reasons put forward by the Player that all the equipment for selection is unsatisfactory, the DCO shall terminate the collection of the Player's blood Sample and this shall be recorded by the DCO.

- (f) When the blood Sample collection kit has been selected, the DCO and the Player shall check that all code numbers match and that this code number is accurately recorded by the DCO on the Doping Control form.
- (g) If the Player or DCO finds that the numbers are not the same, the DCO shall instruct the Player to choose another kit in accordance with section (e) above. The DCO shall record the matter.
- (h) Blood Sample collections shall only be conducted by suitably-qualified medical personnel or by a qualified phlebotomist.
- (i) The Blood Collection Official shall clean the skin with a sterile disinfectant wipe or swab in a location unlikely to adversely affect the Player or his performance and, if necessary, apply a tourniquet. The Blood Collection Official shall take the blood Sample from a superficial vein into the tube. No blood Sample shall be taken from any part of the Player's body other than from the arm or hand. The tourniquet, if applied, shall be immediately removed after the venipuncture has been made.
- (j) The amount of blood removed shall be adequate to satisfy analytical requirements for the Sample analysis to be performed.
- (k) If the amount of blood that can be removed from the Player at the first attempt is insufficient, the Blood Collection Official shall repeat the procedure. The maximum number of attempts shall be three. Should all attempts fail, then the Blood Collection Official shall inform the DCO. The DCO shall terminate the collection of the blood Sample and record this and the reasons for terminating the collection.
- (l) The Blood Collection Official shall apply a dressing to the puncture site/s.
- (m) The Blood Collection Official shall dispose of any used blood sampling equipment not required for completing the Sample Collection session in accordance with the required local standards for handling blood.
- (n) Each tube in which the blood is drawn into shall be marked with a code number. This code number should be recorded by the relevant official on the Player's Doping Control form and the Player should ensure that the code number on the tube corresponds to that

entered by the official on the form. The Player shall insert the tube(s) into the Sample collection kit as directed by the DCO and then be sealed. The Player and the DCO shall check that the sealing of the kit is satisfactory.

- (o) The sealed Sample shall be stored in a manner that protects its integrity, identity and security prior to transport from the Doping Control Station to the WADA accredited laboratory or as otherwise approved by WADA.
- (p) If the Sample requires further on-site processing, such as centrifugation or separation of serum, the Player shall remain to observe the Sample until final sealing in a secure, tamper evident kit.
- (q) Where World Rugby carries out blood sampling, it may also require that the Player provides a urine Sample. If the Player refuses to provide a urine Sample, he may be deemed to have refused to submit to Doping Control and may be subject to sanctions under Regulation 21.10. The urine Sample shall be collected in accordance with the guidelines provided within this Schedule.
- (r) Further procedures relating to the collection of blood Samples shall be in accordance with the WADA Guidelines for Blood Sample Collection which can be located on the WADA website [www.wada-ama.org](http://www.wada-ama.org) under Resources.



## SCHEDULE 2. THE 2017 PROHIBITED LIST. WORLD ANTI-DOPING CODE

Valid 1 January 2017

In accordance with Article 4.2.2 of the World Anti-Doping Code, all *Prohibited Substances* shall be considered as "*Specified Substances*" except Substances in classes S1, S2, S4.4, S4.5, S6.a, and *Prohibited Methods* M1, M2 and M3.

### SUBSTANCES AND METHODS PROHIBITED AT ALL TIMES (IN- AND OUT-OF-COMPETITION)

#### PROHIBITED SUBSTANCES

##### S0. NON-APPROVED SUBSTANCES

Any pharmacological substance which is not addressed by any of the subsequent sections of the List and with no current approval by any governmental regulatory health authority for human therapeutic use (e.g drugs under pre-clinical or clinical development or discontinued, designer drugs, substances approved only for veterinary use) is prohibited at all times.

##### S1. ANABOLIC AGENTS

Anabolic agents are prohibited.

##### 1. Anabolic Androgenic Steroids (AAS)

a. Exogenous\* AAS, including:

**1-androstenediol** (5 $\alpha$ -androst-1-ene-3 $\beta$ ,17 $\beta$ -diol );

**1-androstenedione** (5 $\alpha$ -androst-1-ene-3,17-dione);

**1-testosterone** (17 $\beta$ -hydroxy-5 $\alpha$ -androst-1-en-3-one);

**4-hydroxytestosterone** (4,17 $\beta$ -dihydroxyandrost-4-en-3-one);

**bolandiol** (estr-4-ene-3 $\beta$ ,17 $\beta$ -diol );

**bolasterone**;

**calusterone**;

**clostebol**;

**danazol** ([1,2]oxazolo[4',5':2,3]pregna-4-en-20-yn-17 $\alpha$ -ol);

**dehydrochlormethyltestosterone** (4-chloro-17 $\beta$ -hydroxy-17 $\alpha$ -methylandrosta-1,4-dien-3-one);

**desoxymethyltestosterone** (17 $\alpha$ -methyl-5 $\alpha$ -androst-2-en-17 $\beta$ -ol);

**drostanolone**;

**ethylestrenol** (19-norpregna-4-en-17 $\alpha$ -ol);

**fluoxymesterone**;

**formebolone**;

**furazabol** (17 $\alpha$ -methyl [1,2,5]oxadiazolo[3',4':2,3]-5 $\alpha$ -androstan-17 $\beta$ -ol);

**gestrinone**;

**mestanolone**;

**mesterolone**;

**metandienone** (17 $\beta$ -hydroxy-17 $\alpha$ -methylandrosta-1,4-dien-3-one);

**metenolone**;

**methandriol**;

**methasterone** (17 $\beta$ -hydroxy-2 $\alpha$ ,17 $\alpha$ -dimethyl-5 $\alpha$ -androstan-3-one);

**methyldienolone** (17 $\beta$ -hydroxy-17 $\alpha$ -methylestra-4,9-dien-3-one);

**methyl-1-testosterone** (17 $\beta$ -hydroxy-17 $\alpha$ -methyl-5 $\alpha$ -androst-1-en-3-one);  
**methylnortestosterone** (17 $\beta$ -hydroxy-17 $\alpha$ -methylestr-4-en-3-one);  
**methyltestosterone**;  
**metribolone** (methyltrienolone, 17 $\beta$ -hydroxy-17 $\alpha$ -methylestra-4,9,11-trien-3-one);  
**mibolone**;  
**norboletone**;  
**norclostebol**;  
**norethandrolone**;  
**oxabolone**;  
**oxandrolone**;  
**oxymesterone**;  
**oxymetholone**;  
**prostanazol** (17 $\beta$ -[(tetrahydropyran-2-yl)oxy]-1'H-pyrazolo[3,4:2,3]-5 $\alpha$ -androstane);  
**quinbolone**;  
**stanozolol**;  
**stenbolone**;  
**tetrahydrogestrinone** (17-hydroxy-18 $\alpha$ -homo-19-nor-17 $\alpha$ -pregna-4,9,11-trien-3-one);  
**trenbolone** (17 $\beta$ -hydroxyestr-4,9,11-trien-3-one);

and other substances with a similar chemical structure or similar biological effect(s).

**b. Endogenous\*\* AAS** when administered exogenously:

**19-norandrostenediol** (estr-4-ene-3,17-diol);  
**19-norandrostenedione** (estr-4-ene-3,17-dione);  
**androstenediol** (androst-5-ene-3 $\beta$ ,17 $\beta$ -diol);  
**androstenedione** (androst-4-ene-3,17-dione);  
**boldenone**;  
**boldione** (androsta-1,4-diene-3,17-dione);  
**dihydrotestosterone** (17 $\beta$ -hydroxy-5 $\alpha$ -androstan-3-one);  
**nandrolone** (19-nortestosterone);  
**prasterone** (dehydroepiandrosterone, DHEA, 3 $\beta$ -hydroxyandrost-5-en-17-one);  
**testosterone**;

and their **metabolites** and **isomers**, including but not limited to:

**3 $\beta$ -hydroxy-5 $\alpha$ -androstan-17-one**;  
**5 $\alpha$ -androst-2-ene-17-one**;  
**5 $\alpha$ -androstan-3 $\alpha$ ,17 $\alpha$ -diol**;  
**5 $\alpha$ -androstan-3 $\alpha$ ,17 $\beta$ -diol**;  
**5 $\alpha$ -androstan-3 $\beta$ ,17 $\alpha$ -diol**;  
**5 $\alpha$ -androstan-3 $\beta$ ,17 $\beta$ -diol**;  
**5 $\beta$ -androstan-3 $\alpha$ ,17 $\beta$ -diol**;  
**7 $\alpha$ -hydroxy-DHEA**;  
**7 $\beta$ -hydroxy-DHEA**;  
**4-androstenediol** (androst-4-ene-3 $\beta$ ,17 $\beta$ -diol);  
**5-androstenedione** (androst-5-ene-3,17-dione);  
**7-keto-DHEA**;  
**19-norandrosterone**;  
**19-noretiocholanolone**;  
**androst-4-ene-3 $\alpha$ ,17 $\alpha$ -diol**;  
**androst-4-ene-3 $\alpha$ ,17 $\beta$ -diol**;

androst-4-ene-3 $\beta$ ,17 $\alpha$ -diol;  
androst-5-ene-3 $\alpha$ ,17 $\alpha$ -diol;  
androst-5-ene-3 $\alpha$ ,17 $\beta$ -diol;  
androst-5-ene-3 $\beta$ ,17 $\alpha$ -diol;  
androsterone;  
epi-dihydrotestosterone;  
epitestosterone;  
etiocholanolone.

## **2. Other Anabolic Agents,**

Including but not limited to:

**Clenbuterol, selective androgen receptor modulators (SARMs, e.g. andarine and ostarine), tibolone, zeranol, and zilpaterol.**

For purposes of this section:

\* “exogenous” refers to a substance which is not ordinarily produced by the body naturally.

\*\* “endogenous” refers to a substance which is ordinarily produced by the body naturally.

## **S2. PEPTIDE HORMONES, GROWTH FACTORS, RELATED SUBSTANCES AND MIMETICS**

The following substances, and other substances with similar chemical structure or similar biological effect(s), are prohibited:

### **1. Erythropoietin-Receptor agonists:**

**1.1 Erythropoiesis-Stimulating Agents (ESAs) including e.g.**  
**darbepoietin (dEPO);**  
**erythropoietins (EPO);**  
**EPO-Fc;**  
**EPO-mimetic peptides (EMP), e.g. CNTO 530 and peginesatide;**  
**GATA inhibitors, e.g. K-11706;**  
**methoxy polyethylene glycol-epoetin beta (CERA);**  
**transforming Growth Factor- $\beta$  (TGF- $\beta$ ) inhibitors, e.g. sotatercept,**  
**luspatercept;**

**1.2 Non-erythropoietic EPO-Receptor agonists, e.g.**  
**ARA-290;**  
**asialo EPO;**  
**carbamylated EPO.**

**2. Hypoxia-inducible factor (HIF) stabilizers, e.g. cobalt, molidustat and roxadustat (FG-4592); and HIF activators, e.g. argon and xenon;**

**3. Chorionic Gonadotrophin (CG) and Luteinizing Hormone (LH) and their releasing factors, e.g. buserelin, gonadorelin and leuprorelin, in males;**

**4. Corticotrophins and their releasing factors, e.g corticorelin;**

5. **Growth Hormone (GH)** and its releasing factors including:

- **Growth Hormone Releasing Hormone (GHRH)** and its **analogues**, e.g. **CJC-1295**, **sermorelin** and **tesamorelin**;
- **Growth Hormone Secretagogues (GHS)**, e.g. **ghrelin** and **ghrelin mimetics**, e.g. **anamorelin** and **ipamorelin**;
- **GH-Releasing Peptides (GHRPs)**, e.g. **alexamorelin**, **GHRP-6**, **hexarelin** and **pralmorelin (GHRP-2)**.

Additional prohibited growth factors:

**Fibroblast Growth Factors (FGFs)**; **Hepatocyte Growth Factor (HGF)**; **Insulin-like Growth Factor-1 (IGF-1)** and its **analogues**; **Mechano Growth Factors (MGFs)**; **Platelet-Derived Growth Factor (PDGF)**; **Vascular-Endothelial Growth Factor (VEGF)** and any other growth factor affecting muscle, tendon or ligament protein synthesis/degradation, vascularisation, energy utilization, regenerative capacity or fibre type switching.

### **S3. BETA-2 AGONISTS**

All selective and non-selective **beta-2 agonists**, including all **optical isomers**, are prohibited.;

Including, but not limited to:

**Fenoterol**; **formoterol**; **higenamine**; **indacaterol**; **olodaterol**; **procaterol**; **reproterol**; **salbutamol**; **salmeterol**; **terbutaline**; **vilanterol**.

Except:

- **Inhaled salbutamol**: maximum 1600 micrograms over 24 hours); , not to exceed 800 micrograms every 12 hours;
- **Inhaled formoterol**: maximum delivered dose of 54 micrograms over 24 hours;
- **Inhaled salmeterol**: maximum 200 micrograms over 24 hours.

The presence in urine of salbutamol in excess of 1000 ng/mL or formoterol in excess of 40 ng/mL is presumed not to be an intended therapeutic use of the substance and will be considered as an *Adverse Analytical Finding (AAF)* unless the *Athlete* proves, through a controlled pharmacokinetic study, that the abnormal result was the consequence of the use of the therapeutic dose (by inhalation) up to the maximum dose indicated above.

### **S4. HORMONE AND METABOLIC MODULATORS**

The following **hormone** and **metabolic modulators** are prohibited:

1. **Aromatase inhibitors** including, but not limited to:

**4-androstene-3,6,17 trione (6-oxo)**;  
**aminoglutethimide**;  
**anastrozole**;  
**androsta-1,4,6-triene-3,17-dione (androstatrienedione)**;



**androsta-3,5-diene-7,17-dione** (arimistane);  
**exemestane**;  
**formestane**;  
**letrozole**;  
**testolactone**.

**2. Selective estrogen receptor modulators (SERMs) including, but not limited to:**

**raloxifene**;  
**tamoxifen**;  
**toremifene**.

**3. Other anti-estrogenic substances including, but not limited to:**

**clomiphene**;  
**cyclofenil**;  
**fulvestrant**.

**4. Agents modifying myostatin function(s) including, but not limited, to: myostatin inhibitors.**

**5. Metabolic modulators:**

**5.1 Activators of the AMP-activated protein kinase (AMPK), e.g. AICAR; and Peroxisome Proliferator Activated Receptor  $\delta$  (PPAR $\delta$ ) agonists, e.g. GW 1516;**

**5.2 Insulins and insulin-mimetics;**

**5.3 Meldonium;**

**5.4 Trimetazidine.**

**S5. DIURETICS AND OTHER MASKING AGENTS**

The following **diuretics** and **masking agents** are prohibited, as are other substances with a similar chemical structure or similar biological effect(s).

Including, but not limited to:

- **Desmopressin; probenecid; plasma expanders, e.g. glycerol and intravenous administration of albumin, dextran, hydroxyethyl starch and mannitol.**
- **Acetazolamide; amiloride; bumetanide; canrenone; chlortalidone; etacrynic acid; furosemide; indapamide; metolazone; spironolactone; thiazides, e.g. bendroflumethiazide, chlorothiazide and hydrochlorothiazide; triamterene and vaptans, e.g. tolvaptan.**

Except:

- **Drospirenone; pamabrom; and ophthalmic use of carbonic anhydrase inhibitors (e.g. dorzolamide, brinzolamide).**

- Local administration of felypressin in dental anaesthesia.

The detection in an *Athlete's Sample* at all times or *In-Competition*, as applicable, of any quantity of the following substances subject to threshold limits: formoterol, salbutamol, cathine, ephedrine, methylephedrine and pseudoephedrine, in conjunction with a diuretic or masking agent, will be considered as an *Adverse Analytical Finding* unless the *Athlete* has an approved *Therapeutic Use Exemption (TUE)* for that substance in addition to the one granted for the diuretic or masking agent.

## PROHIBITED METHODS

### M1. MANIPULATION OF BLOOD AND BLOOD COMPONENTS

The following are prohibited:

1. The *Administration* or reintroduction of any quantity of autologous, allogenic (homologous) or heterologous blood, or red blood cell products of any origin into the circulatory system.
2. Artificially enhancing the uptake, transport or delivery of oxygen.  
Including, but not limited to:  
**Perfluorochemicals; efaproxiral (RSR13) and modified haemoglobin products**, e.g. haemoglobin-based blood substitutes and microencapsulated haemoglobin products, excluding supplemental oxygen by inhalation.
3. Any form of intravascular manipulation of the blood or blood components by physical or chemical means.

### M2. CHEMICAL AND PHYSICAL MANIPULATION

The following are prohibited:

1. *Tampering, or Attempting to Tamper*, to alter the integrity and validity of *Samples* collected during *Doping Control*.  
Including, but not limited to:  
Urine substitution and/or adulteration, e.g. proteases.
2. Intravenous infusions and/or injections of more than 50 mL per 6 hour period except for those legitimately received in the course of hospital admissions, surgical procedures or clinical investigations.

### M3. GENE DOPING

The following, with the potential to enhance sport performance, are prohibited:

1. The transfer of polymers of nucleic acids or nucleic acid analogues;
2. The use of normal or genetically modified cells.

**SUBSTANCES AND METHODS  
PROHIBITED IN-COMPETITION**

In addition to the categories S0 to S5 and M1 to M3 defined above,  
the following categories are prohibited *In-Competition*:

**PROHIBITED SUBSTANCES****S6. STIMULANTS**

All **stimulants**, including all **optical isomers**, e.g. *d*- and *l*- where relevant, are prohibited.

Stimulants include:

a: Non-Specified Stimulants:

**Adrafinil;**  
**amfepramone;**  
**amfetamine;**  
**amfetaminil;**  
**amiphenazole;**  
**benfluorex;**  
**benzylpiperazine;**  
**bromantan;**  
**clobenzorex;**  
**cocaine;**  
**cropropamide;**  
**crotetamide;**  
**fencamine;**  
**fenetylline;**  
**fenfluramine;**  
**fenproporex;**  
**fonturacetam** [4-phenylpiracetam (carphedon)];  
**furfenorex;**  
**lisdexamfetamine;**  
**mefenorex;**  
**mephentermine;**  
**mesocarb;**  
**metamfetamine(*d*-);**  
**p-methylamphetamine;**  
**modafinil;**  
**norfenfluramine;**  
**phendimetrazine;**  
**phentermine;**  
**prenylamine;**  
**prolintane.**

A stimulant not expressly listed in this section is a Specified Substance.

b: Specified Stimulants.

Including, but not limited to:

Last update: 3 January, 2017

**4-methylhexan-2-amine** (methylhexaneamine);  
**benzfetamine**;  
**cathine**<sup>\*\*</sup>;  
**cathinone** and its analogues, e.g. **mephedrone**, **methedrone**, and **α-pyrrolidinovalerophenone**;  
**dimethylamphetamine**;  
**ephedrine**<sup>\*\*\*</sup>;  
**epinephrine**<sup>\*\*\*\*</sup> (adrenaline);  
**etamivan**;  
**etilamfetamine**;  
**etilefrine**;  
**famprofazone**;  
**fenbutrazate**;  
**fencamfamin**;  
**heptaminol**;  
**hydroxyamfetamine** (parahydroxyamphetamine);  
**isometheptene**;  
**levmetamfetamine**;  
**meclofenoxate**;  
**methylenedioxyamphetamine**;  
**methylephedrine**<sup>\*\*\*</sup>;  
**methylphenidate**;  
**nikethamide**;  
**norfenefrine**;  
**octopamine**;  
**oxilofrine** (methylnsynephrine);  
**pemoline**;  
**pentetrazol**;  
**phenethylamine** and its **derivatives**;  
**phenmetrazine**;  
**phenpromethamine**;  
**propylhexedrine**;  
**pseudoephedrine**<sup>\*\*\*\*\*</sup>;  
**selegiline**;  
**sibutramine**;  
**strychnine**;  
**tenamfetamine** (methylenedioxyamphetamine);  
**tuaminoheptane**.

and other substances with a similar chemical structure or similar biological effect(s).

Except:

- Clonidine
- Imidazole derivatives for topical/ophthalmic use and those stimulants included in the 2017 Monitoring Program\*.

\* Bupropion, caffeine, nicotine, phenylephrine, phenylpropanolamine, pipradrol, and synephrine: These substances are included in the 2017 Monitoring Program, and are not considered *Prohibited Substances*.

- \*\* Cathine: Prohibited when its concentration in urine is greater than 5 micrograms per milliliter.
- \*\*\* Ephedrine and methylephedrine: Prohibited when the concentration of either in urine is greater than 10 micrograms per milliliter.
- \*\*\*\* Epinephrine (adrenaline): Not prohibited in local administration, e.g. nasal, ophthalmologic, or co-administration with local anaesthetic agents.
- \*\*\*\*\* Pseudoephedrine: Prohibited when its concentration in urine is greater than 150 micrograms per milliliter.

### **S7. NARCOTICS**

Prohibited:

**Buprenorphine;**  
**dextromoramide;**  
**diamorphine** (heroin);  
**fentanyl** and its **derivatives;**  
**hydromorphone;**  
**methadone;**  
**morphine;**  
**nicomorphime;**  
**oxycodone;**  
**oxymorphone;**  
**pentazocine;**  
**pethidine.**

### **S8. CANNABINOIDS**

Prohibited:

- **Natural**, e.g. **cannabis**, **hashish** and **marijuana**, or **synthetic  $\Delta 9$ -tetrahydrocannabinol (THC)**.
- **Cannabimimetics**, e.g. **“Spice”**, **JWH-018**, **JWH-073**, **HU-210**.

### **S9. GLUCOCORTICOIDS**

All **glucocorticoids** are prohibited when administered by oral, intravenous, intramuscular or rectal routes.

## **SUBSTANCES PROHIBITED IN PARTICULAR SPORTS**

### **P1. ALCOHOL**

Alcohol (**ethanol**) is prohibited *In-Competition* only, in the following sports. Detection will be conducted by analysis of breath and/or blood. The doping violation threshold is equivalent to a blood alcohol concentration of 0.10 g/L.

- Air Sports (FAI)
- Archery (WA)
- Automobile (FIA)
- Powerboating (UIM)

## **P2. BETA-BLOCKERS**

**Beta-blockers** are prohibited *In-Competition* only, in the following sports, and also prohibited *Out-of-Competition* where indicated.

- Archery (WA)\*
- Automobile (FIA)
- Billiards (all disciplines) (WCBS)
- Darts (WDF)
- Golf (IGF)
- Shooting (ISSF, IPC)\*
- Skiing/Snowboarding (FIS) in ski jumping, freestyle aerials/halfpipe and snowboard halfpipe/big air
- Underwater sports (CMAS) in constant-weight apnoea with or without fins, dynamic apnoea with and without fins, free immersion apnoea, Jump Blue apnoea, spearfishing, static apnoea, target shooting and variable weight apnoea.

\*Also prohibited *Out-of-Competition*

Including, but not limited to:

**Acebutolol;**  
**alprenolol;**  
**atenolol;**  
**betaxolol;**  
**bisoprolol;**  
**bunolol;**  
**carteolol;**  
**carvedilol;**  
**celiprolol;**  
**esmolol;**  
**labetalol;**  
**levobunolol;**  
**metipranolol;**  
**metoprolol;**  
**nadolol;**  
**oxprenolol;**  
**pindolol;**  
**propranolol;**  
**sotalol;**  
**timolol.**

## SCHEDULE 3(a). WADA INTERNATIONAL STANDARD FOR THERAPEUTIC USE EXEMPTIONS (TUE)

- 3.2 Further defined term from the International Standard for the Protection of Privacy and Personal Information that is used in the International Standard for Therapeutic Use Exemptions:

**Personal Information**: Information, including without limitation Sensitive Personal Information, relating to an identified or identifiable *Participant* or relating to other *Persons* whose information is Processed solely in the context of an *Anti-Doping Organization's Anti-Doping Activities*.

*[3.2 Comment: It is understood that Personal Information includes, but is not limited to, information relating to an Athlete's name, date of birth, contact details and sporting affiliations, whereabouts, designated therapeutic use exemptions (if any), anti-doping test results, and results management (including disciplinary hearings, appeals and sanctions). Personal Information also includes personal details and contact information relating to other Persons, such as medical professionals and other Persons working with, treating or assisting an Athlete in the context of Anti-Doping Activities. Such information remains Personal Information and is regulated by this Standard for the entire duration of its Processing, irrespective of whether the relevant individual remains involved in organized sport.]*

- 3.3 Further defined terms specific to the International Standard for Therapeutic Use Exemptions:

**Therapeutic**: Of or relating to the treatment of a medical condition by remedial agents or methods; or providing or assisting in a cure.

**Therapeutic Use Exemption Committee (or "TUEC")**: The panel established by an *Anti-Doping Organization* to consider applications for *TUEs*.

**WADA TUEC**: The panel established by *WADA* to review the *TUE* decisions of other *Anti-Doping Organizations*.

### 3.4 Interpretation:

- 3.4.1 Unless otherwise specified, references to articles are references to articles of the International Standard for Therapeutic Use Exemptions.
- 3.4.2 The comments annotating various provisions of the International Standard for Therapeutic Use Exemptions shall be used to interpret that *International Standard*.
- 3.4.3 The official text of the International Standard for Therapeutic Use Exemptions shall be maintained by *WADA* and shall be published in English and French. In the event of any conflict between the English and French versions, the English version shall prevail.

## PART TWO: STANDARDS AND PROCESS FOR GRANTING *TUES*

### 4.0 Obtaining a *TUE*

- 4.1 An *Athlete* may be granted a *TUE* if (and only if) he/she can show, by a balance of probability, that each of the following conditions is met:
- a. The *Prohibited Substance* or *Prohibited Method* in question is needed to treat an acute or chronic medical condition, such that the *Athlete* would experience a significant impairment to health if the *Prohibited Substance* or *Prohibited Method* were to be withheld.
  - b. The Therapeutic Use of the *Prohibited Substance* or *Prohibited Method* is highly unlikely to produce any additional enhancement of performance beyond what might be anticipated by a return to the *Athlete's* normal state of health following the treatment of the acute or chronic medical condition.
  - c. There is no reasonable Therapeutic alternative to the *Use* of the *Prohibited Substance* or *Prohibited Method*.
  - d. The necessity for the *Use* of the *Prohibited Substance* or *Prohibited Method* is not a consequence, wholly or in part, of the prior *Use* (without a *TUE*) of a substance or method which was prohibited at the time of such *Use*.

*[Comment to 4.1: When a TUEC is deciding whether or not to recognize a TUE granted by another Anti-Doping Organization (see Article 7, below), and when WADA is reviewing a decision to grant (or not to grant) a TUE (see Article 8, below), the issue will be the same as it is for a TUEC that is considering an application for a TUE under article 6, below, i.e., has the Athlete demonstrated by a balance of probability that each of the conditions set out in article 4.1 is met?]*

*The WADA documents titled "Medical Information to Support the Decisions of TUECs", posted on WADA's website, should be used to assist in the application of these criteria in relation to particular medical conditions.]*

- 4.2 Unless one of the exceptions set out in Article 4.3 applies, an *Athlete* who needs to *Use* a *Prohibited Substance* or *Prohibited Method* for Therapeutic reasons must obtain a *TUE* prior to *Using* or *Possessing* the substance or method in question.
- 4.3 An *Athlete* may only be granted retroactive approval for his/her Therapeutic Use of a *Prohibited Substance* or *Prohibited Method* (i.e., a retroactive *TUE*) if:
- a. Emergency treatment or treatment of an acute medical condition was necessary; or
  - b. Due to other exceptional circumstances, there was insufficient time or opportunity for the *Athlete* to submit, or for the TUEC to consider, an application for the *TUE* prior to *Sample* collection; or



- c. The applicable rules required the *Athlete* (see comment to Article 5.1) or permitted the *Athlete* (see Code Article 4.4.5) to apply for a retroactive *TUE*; or

*[Comment to 4.3(c): Such Athletes are strongly advised to have a medical file prepared and ready to demonstrate their satisfaction of the TUE conditions set out at Article 4.1, in case an application for a retroactive TUE is necessary following Sample collection.]*

- d. It is agreed, by WADA and by the *Anti-Doping Organization* to whom the application for a retroactive *TUE* is or would be made, that fairness requires the grant of a retroactive *TUE*.

*[Comment to 4.3(d): If WADA and/or the Anti-Doping Organization do not agree to the application of Article 4.3(d), that may not be challenged either as a defense to proceedings for an anti-doping rule violation, or by way of appeal, or otherwise.]*

## 5.0 TUE Responsibilities of Anti-Doping Organizations

- 5.1 Code Article 4.4 specifies (a) which *Anti-Doping Organizations* have authority to make *TUE* decisions; (b) how those *TUE* decisions should be recognized and respected by other *Anti-Doping Organizations*; and (c) when *TUE* decisions may be reviewed and/or appealed.

*[Comment to 5.1: See Annex 1 for a flow-chart summarizing the key provisions of Code Article 4.4.]*

*Code Article 4.4.2 specifies the authority of a National Anti-Doping Organization to make TUE decisions in respect of Athletes who are not International-Level Athletes. In case of dispute as to which National Anti-Doping Organization should deal with the TUE application of an Athlete who is not an International-Level Athlete, WADA will decide. WADA's decision will be final and not subject to appeal.*

*Where national policy requirements and imperatives lead a National Anti-Doping Organization to prioritize certain sports over others in its test distribution planning (as contemplated by Article 4.4.1 of the International Standard for Testing and Investigations), the National Anti-Doping Organization may decline to consider advance applications for TUEs from Athletes in some or all of the non-priority sports, but in that case it must permit any such Athlete from whom a Sample is subsequently collected to apply for a retroactive TUE. The National Anti-Doping Organization should publicize any such policy on its website for the benefit of affected Athletes.]*

- 5.2 Each *National Anti-Doping Organization*, *International Federation* and *Major Event Organization* must establish a TUEC to consider whether applications for grant or recognition of *TUEs* meet the conditions set out in Article 4.1.

*[Comment to 5.2: While a Major Event Organization may choose to recognize pre-existing TUEs automatically, there must be a mechanism for Athletes participating in the Event to obtain a new TUE if the need arises. It is up to each Major Event Organization whether it sets up its own TUEC for this purpose, or*

*rather whether it outsources the task by agreement to a third party (such as Sport Accord). The aim in each case should be to ensure that Athletes competing in such Events have the ability to obtain TUEs quickly and efficiently before they compete.]*

- a. TUECs should include at least three physicians with experience in the care and treatment of *Athletes* and a sound knowledge of clinical, sports and exercise medicine. In cases involving *Athletes* with impairments, at least one TUEC member should possess general experience in the care and treatment of *Athletes* with impairments, or possess specific experience in relation to the *Athlete's* particular impairment(s).
  - b. In order to ensure a level of independence of decisions, at least a majority of the members of a TUEC should have no political responsibility in the *Anti-Doping Organization* that appoints them. All members of the TUEC must sign a conflict of interest and confidentiality declaration. (A template declaration is available on WADA's website).
- 5.3** Each *National Anti-Doping Organization*, International Federation and *Major Event Organization* must establish a clear process for applying to its TUEC for a *TUE* that complies with the requirements of this *International Standard*. It must also publish details of that process by (at a minimum) posting the information in a conspicuous place on its website and sending the information to WADA. WADA may re-publish the same information on its own website.
- 5.4** Each *National Anti-Doping Organization*, International Federation and *Major Event Organization* must promptly report (in English or French) all decisions of its TUEC granting or denying *TUEs*, and all decisions to recognize or refusing to recognize other *Anti-Doping Organizations' TUE* decisions, through ADAMS or any other system approved by WADA. In respect of *TUEs* granted, the information reported shall include (in English or French):
- a. not only the approved substance or method, but also the dosage(s), frequency and route of *Administration* permitted, the duration of the *TUE*, and any conditions imposed in connection with the *TUE*; and
  - b. the *TUE* application form and the relevant clinical information (translated into English or French) establishing that the Article 4.1 conditions have been satisfied in respect of such *TUE* (for access only by WADA, the *Athlete's National Anti-Doping Organization* and International Federation, and the *Major Event Organization* organizing an *Event* in which the *Athlete* wishes to compete).

*[Comment to 5.4: The process of recognition of TUEs is greatly facilitated by use of ADAMS.]*

- 5.5** When a *National Anti-Doping Organization* grants a *TUE* to an *Athlete*, it must warn him/her in writing (a) that that *TUE* is valid at national level only,

and (b) that if the *Athlete* becomes an *International-Level Athlete* or competes in an *International Event*, that *TUE* will not be valid for those purposes unless it is recognized by the relevant *International Federation* or *Major Event Organization* in accordance with Article 7.1. Thereafter, the *National Anti-Doping Organization* should help the *Athlete* to determine when he/she needs to submit the *TUE* to an *International Federation* or *Major Event Organization* for recognition, and should guide and support the *Athlete* through the recognition process.

**5.6** Each *International Federation* and *Major Event Organization* must publish a notice (at a minimum, by posting it in a conspicuous place on its website and sending it to *WADA*) that sets out clearly (1) which *Athletes* coming under its jurisdiction are required to apply to it for a *TUE*, and when; (2) which *TUE* decisions of other *Anti-Doping Organizations* it will automatically recognize in lieu of such application, in accordance with Article 7.1(a); and (3) which *TUE* decisions of other *Anti-Doping Organizations* will have to be submitted to it for recognition, in accordance with Article 7.1(b). *WADA* may re-publish the notice on its own website.

**5.7** Any *TUE* that an *Athlete* has obtained from a *National Anti-Doping Organization* shall not be valid if the *Athlete* becomes an *International-Level Athlete* or competes in an *International Event* unless and until the relevant *International Federation* recognizes that *TUE* in accordance with Article 7.0. Any *TUE* that an *Athlete* has obtained from an *International Federation* shall not be valid if the *Athlete* competes in an *International Event* organized by a *Major Event Organization*, unless and until the relevant *Major Event Organization* recognizes that *TUE* in accordance with Article 7.0. As a result, if the *International Federation* or *Major Event Organization* (as applicable) declines to recognize that *TUE*, then (subject to the *Athlete's* rights of review and appeal) that *TUE* may not be relied upon to excuse the presence, *Use*, *Possession* or *Administration* of the *Prohibited Substance* or *Prohibited Method* mentioned in the *TUE* vis-à-vis that *International Federation* or *Major Event Organization*.

## **6.0 TUE Application Process**

**6.1** An *Athlete* who needs a *TUE* should apply as soon as possible. For substances prohibited *In-Competition* only, the *Athlete* should apply for a *TUE* at least 30 days before his/her next *Competition*, unless it is an emergency or exceptional situation. The *Athlete* should apply to his/her *National Anti-Doping Organization*, *International Federation* and/or a *Major Event Organization* (as applicable), using the *TUE* application form provided. *Anti-Doping Organizations* shall make the application form they want *Athletes* to use available for download from their websites. That form must be based on the template set out in Annex 2. The template may be modified by *Anti-Doping Organizations* to include additional requests for information, but no sections or items may be removed.

- 6.2** The *Athlete* should submit the *TUE* application form to the relevant *Anti-Doping Organization* via *ADAMS* or as otherwise specified by the *Anti-Doping Organization*. The form must be accompanied by:
- a. a statement by an appropriately qualified physician, attesting to the need for the *Athlete* to Use the *Prohibited Substance* or *Prohibited Method* in question for Therapeutic reasons; and
  - b. a comprehensive medical history, including documentation from the original diagnosing physician(s) (where possible) and the results of all examinations, laboratory investigations and imaging studies relevant to the application.

*[Comment to 6.2(b): The information submitted in relation to the diagnosis, treatment and duration of validity should be guided by the WADA documents titled "Medical Information to Support the Decisions of TUECs".]*

- 6.3** The *Athlete* should keep a complete copy of the *TUE* application form and of all materials and information submitted in support of that application.
- 6.4** A *TUE* application will only be considered by the TUEC following the receipt of a properly completed application form, accompanied by all relevant documents. Incomplete applications will be returned to the *Athlete* for completion and re-submission.
- 6.5** The TUEC may request from the *Athlete* or his/her physician any additional information, examinations or imaging studies, or other information that it deems necessary in order to consider the *Athlete*'s application; and/or it may seek the assistance of such other medical or scientific experts as it deems appropriate.
- 6.6** Any costs incurred by the *Athlete* in making the *TUE* application and in supplementing it as required by the TUEC are the responsibility of the *Athlete*.
- 6.7** The TUEC shall decide whether or not to grant the application as soon as possible, and usually (i.e., unless exceptional circumstances apply) within no more than 21 days of receipt of a complete application. Where a *TUE* application is made a reasonable time prior to an *Event*, the TUEC must use its best endeavours to issue its decision before the start of the *Event*.
- 6.8** The TUEC's decision must be communicated in writing to the *Athlete* and must be made available to *WADA* and to other *Anti-Doping Organizations* via *ADAMS* or any other system approved by *WADA*, in accordance with Article 5.4.
- a. A decision to grant a *TUE* must specify the dosage(s), frequency, route and duration of *Administration* of the *Prohibited Substance* or *Prohibited Method* in question that the TUEC is permitting, reflecting the clinical

circumstances, as well as any conditions imposed in connection with the *TUE*.

- b. A decision to deny a *TUE* application must include an explanation of the reason(s) for the denial.

- 6.9** Each *TUE* will have a specified duration, as decided by the TUEC, at the end of which the *TUE* will expire automatically. If the *Athlete* needs to continue to *Use* the *Prohibited Substance* or *Prohibited Method* after the expiry date, he/she must submit an application for a new *TUE* well in advance of that expiry date, so that there is sufficient time for a decision to be made on the application before the expiry date.

*[Comment to 6.9: The duration of validity should be guided by the WADA documents titled “Medical Information to Support the Decisions of TUECs”.]*

- 6.10** A *TUE* will be withdrawn prior to expiry if the *Athlete* does not promptly comply with any requirements or conditions imposed by the *Anti-Doping Organization* granting the *TUE*. Alternatively a *TUE* may be reversed upon review by *WADA* or on appeal.

- 6.11** Where an *Adverse Analytical Finding* is issued shortly after a *TUE* for the *Prohibited Substance* in question has expired or has been withdrawn or reversed, the *Anti-Doping Organization* conducting the initial review of the *Adverse Analytical Finding* (Code Article 7.2) shall consider whether the finding is consistent with *Use* of the *Prohibited Substance* prior to the expiry, withdrawal or reversal of the *TUE*. If so, such *Use* (and any resulting presence of the *Prohibited Substance* in the *Athlete’s Sample*) is not an anti-doping rule violation.

- 6.12** In the event that, after his/her *TUE* is granted, the *Athlete* requires a materially different dosage, frequency, route or duration of *Administration* of the *Prohibited Substance* or *Prohibited Method* to that specified in the *TUE*, he/she must apply for a new *TUE*. If the presence, *Use*, *Possession* or *Administration* of the *Prohibited Substance* or *Prohibited Method* is not consistent with the terms of the *TUE* granted, the fact that the *Athlete* has the *TUE* will not prevent the finding of an anti-doping rule violation.

## **7.0 TUE Recognition Process**

- 7.1** Code Article 4.4 requires *Anti-Doping Organizations* to recognize *TUEs* granted by other *Anti-Doping Organizations* that satisfy the Article 4.1 conditions. Therefore, if an *Athlete* who becomes subject to the *TUE* requirements of an *International Federation* or *Major Event Organization* already has a *TUE*, he/she should not submit an application for a new *TUE* to the *International Federation* or *Major Event Organization*. Instead:

- a. The *International Federation* or *Major Event Organization* may publish notice that it will automatically recognize *TUE* decisions made pursuant to

Code Article 4.4 (or certain categories of such decisions, e.g., those made by specified *Anti-Doping Organizations*, or those relating to particular *Prohibited Substances*), provided that such *TUE* decisions have been reported in accordance with Article 5.4 and therefore are available for review by *WADA*. If the *Athlete's TUE* falls into a category of *TUEs* that are automatically recognized in this way at the time the *TUE* is granted, he/she does not need to take any further action.

*[Comment to 7.1(a): To ease the burden on Athletes, automatic recognition of TUE decisions once they have been reported in accordance with Article 5.4 is strongly encouraged. If an International Federation or Major Event Organizer is not willing to grant automatic recognition of all such decisions, it should grant automatic recognition of as many such decisions as possible, e.g., by publishing a list of Anti-Doping Organizations whose TUE decisions it will recognize automatically, and/or a list of those Prohibited Substances for which it will automatically recognize TUEs. Publication should be in the same manner as is set out in Article 5.3, i.e., the notice should be posted on the International Federation's website and sent to WADA and to National Anti-Doping Organizations.]*

- b. In the absence of such automatic recognition, the *Athlete* shall submit a request for recognition of the *TUE* to the International Federation or *Major Event Organization* in question, either via *ADAMS* or as otherwise specified by that International Federation or *Major Event Organization*. The request should be accompanied by a copy of the *TUE* and the original *TUE* application form and supporting materials referenced at Articles 6.1 and 6.2 (unless the *Anti-Doping Organization* that granted the *TUE* has already made the *TUE* and supporting materials available via *ADAMS* or other system approved by *WADA*, in accordance with Article 5.4).
- 7.2** Incomplete requests for recognition of a *TUE* will be returned to the *Athlete* for completion and re-submission. In addition, the TUEC may request from the *Athlete* or his/her physician any additional information, examinations or imaging studies, or other information that it deems necessary in order to consider the *Athlete's* request for recognition of the *TUE*; and/or it may seek the assistance of such other medical or scientific experts as it deems appropriate.
- 7.3** Any costs incurred by the *Athlete* in making the request for recognition of the *TUE* and in supplementing it as required by the TUEC are the responsibility of the *Athlete*.
- 7.4** The TUEC shall decide whether or not to recognize the *TUE* as soon as possible, and usually (i.e., unless exceptional circumstances apply) within no more than 21 days of receipt of a complete request for recognition. Where the request is made a reasonable time prior to an *Event*, the TUEC must use its best endeavors to issue its decision before the start of the *Event*.
- 7.5** The TUEC's decision will be notified in writing to the *Athlete* and will be made available to *WADA* and to other *Anti-Doping Organizations* via *ADAMS* or

any other system approved by *WADA*. A decision not to recognize a *TUE* must include an explanation of the reason(s) for the non-recognition.

## 8.0 Review of *TUE* Decisions by *WADA*

8.1 *Code* Article 4.4.6 provides that *WADA*, in certain cases, must review *TUE* decisions of International Federations, and that it may review any other *TUE* decisions, in each case to determine compliance with the Article 4.1 conditions. *WADA* shall establish a WADA TUEC that meets the requirements of Article 5.2 to carry out such reviews.

8.2 Each request for review must be submitted to *WADA* in writing, and must be accompanied by payment of the application fee established by *WADA*, as well as copies of all of the information specified in Article 6.2 (or, in the case of review of a *TUE* denial, all of the information that the *Athlete* submitted in connection with the original *TUE* application). The request must be copied to the party whose decision would be the subject of the review, and to the *Athlete* (if he/she is not requesting the review).

8.3 Where the request is for review of a *TUE* decision that *WADA* is not obliged to review, *WADA* shall advise the *Athlete* as soon as practicable following receipt of the request whether or not it will refer the *TUE* decision to the WADA TUEC for review. If *WADA* decides not to refer the *TUE* decision, it will return the application fee to the *Athlete*. Any decision by *WADA* not to refer the *TUE* decision to the WADA TUEC is final and may not be appealed. However, the *TUE* decision may still be appealable, as set out in *Code* Article 4.4.7.

8.4 Where the request is for review of a *TUE* decision of an International Federation that *WADA* is obliged to review, *WADA* may nevertheless refer the decision back to the International Federation (a) for clarification (for example, if the reasons are not clearly set out in the decision); and/or (b) for re-consideration by the International Federation (for example, if the *TUE* was only denied because medical tests or other information required to demonstrate satisfaction of the Article 4.1 conditions were missing).

8.5 Where a request for review is referred to the WADA TUEC, the WADA TUEC may seek additional information from the *Anti-Doping Organization* and/or the *Athlete*, including further studies as described in Article 6.5, and/or it may obtain the assistance of other medical or scientific experts as it deems appropriate.

8.6 The WADA TUEC shall reverse any grant of a *TUE* that does not comply with the Article 4.1 conditions. Where the *TUE* reversed was a prospective *TUE* (rather than a retroactive *TUE*), such reversal shall take effect upon the date specified by *WADA* (which shall not be earlier than the date of *WADA*'s notification to the *Athlete*). The reversal shall not apply retroactively and the *Athlete*'s results prior to such notification shall not be *Disqualified*. Where the *TUE* reversed was a retroactive *TUE*, however, the reversal shall also be retroactive.

- 8.7 The WADA TUEC shall reverse any denial of a *TUE* where the *TUE* application met the Article 4.1 conditions, i.e., it shall grant the *TUE*.
- 8.8 Where the WADA TUEC reviews a decision of an International Federation that has been referred to it pursuant to *Code* Article 4.4.3 (i.e., a mandatory review), it may require whichever *Anti-Doping Organization* “loses” the review (i.e., the *Anti-Doping Organization* whose view it does not uphold) (a) to reimburse the application fee to the party that referred the decision to *WADA* (if applicable); and/or (b) to pay the costs incurred by *WADA* in respect of that review, to the extent they are not covered by the application fee.
- 8.9 Where the WADA TUEC reverses a *TUE* decision that *WADA* has decided in its discretion to review, *WADA* may require the *Anti-Doping Organization* that made the decision to pay the costs incurred by *WADA* in respect of that review.
- 8.10 *WADA* shall communicate the reasoned decision of the WADA TUEC promptly to the *Athlete* and to his/her *National Anti-Doping Organization* and International Federation (and, if applicable, the *Major Event Organization*).
- 9.0 **Confidentiality of Information**
- 9.1 The collection, storage, processing, disclosure and retention of Personal Information during the *TUE* process by *Anti-Doping Organizations* and *WADA* shall comply with the International Standard for the Protection of Privacy and Personal Information.
- 9.2 An *Athlete* applying for the grant of a *TUE* or for recognition of a *TUE* shall provide written consent:
- a. for the transmission of all information pertaining to the application to members of all TUECs with authority under this *International Standard* to review the file and, as required, other independent medical or scientific experts, and to all necessary staff (including *WADA* staff) involved in the management, review or appeal of *TUE* applications;
  - b. for the *Athlete’s* physician(s) to release to the TUEC upon request any health information that the TUEC deems necessary in order to consider and determine the *Athlete’s* application; and
  - c. for the decision on the application to be made available to all *Anti-Doping Organizations* with *Testing* authority and/or results management authority over the *Athlete*.

*[Comment to 9.2: Prior to collecting Personal Information or obtaining consent from an *Athlete*, the *Anti-Doping Organization* shall communicate to the *Athlete* the information set out in Article 7.1 of the *International Standard for the Protection of Privacy and Personal Information*.]*



- 9.3** The *TUE* application shall be dealt with in accordance with the principles of strict medical confidentiality. The members of the TUEC, independent experts and the relevant staff of the *Anti-Doping Organization* shall conduct all of their activities relating to the process in strict confidence and shall sign appropriate confidentiality agreements. In particular they shall keep the following information confidential:
- a. All medical information and data provided by the *Athlete* and physician(s) involved in the *Athlete's* care.
  - b. All details of the application, including the name of the physician(s) involved in the process.
- 9.4** Should the *Athlete* wish to revoke the right of the TUEC to obtain any health information on his/her behalf, the *Athlete* shall notify his/her medical practitioner in writing of such revocation; provided that, as a result of that revocation, the *Athlete's* application for a *TUE* or for recognition of an existing *TUE* will be deemed withdrawn without approval/recognition having been granted.
- 9.5** *Anti-Doping Organizations* shall only use information submitted by an *Athlete* in connection with a *TUE* application to evaluate the application and in the context of potential anti-doping rule violation investigations and proceedings.

**ANNEX 1. CODE ARTICLE 4.4 FLOW-CHART**

1. TUE procedure if Athlete is not an International-Level Athlete when need for TUE arises

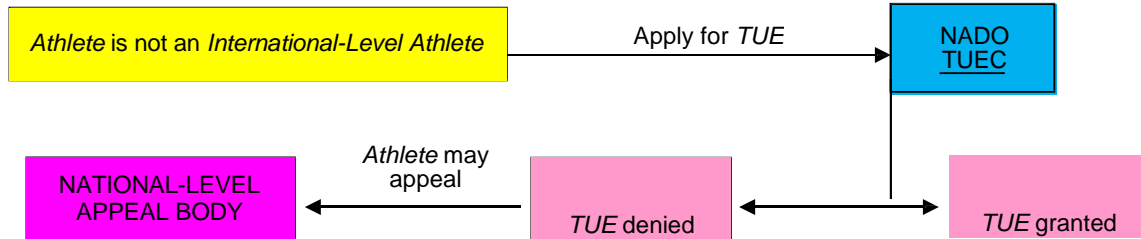

2. Athlete enters Event for which Major Event Organization (or "MEO") has its own TUE requirements

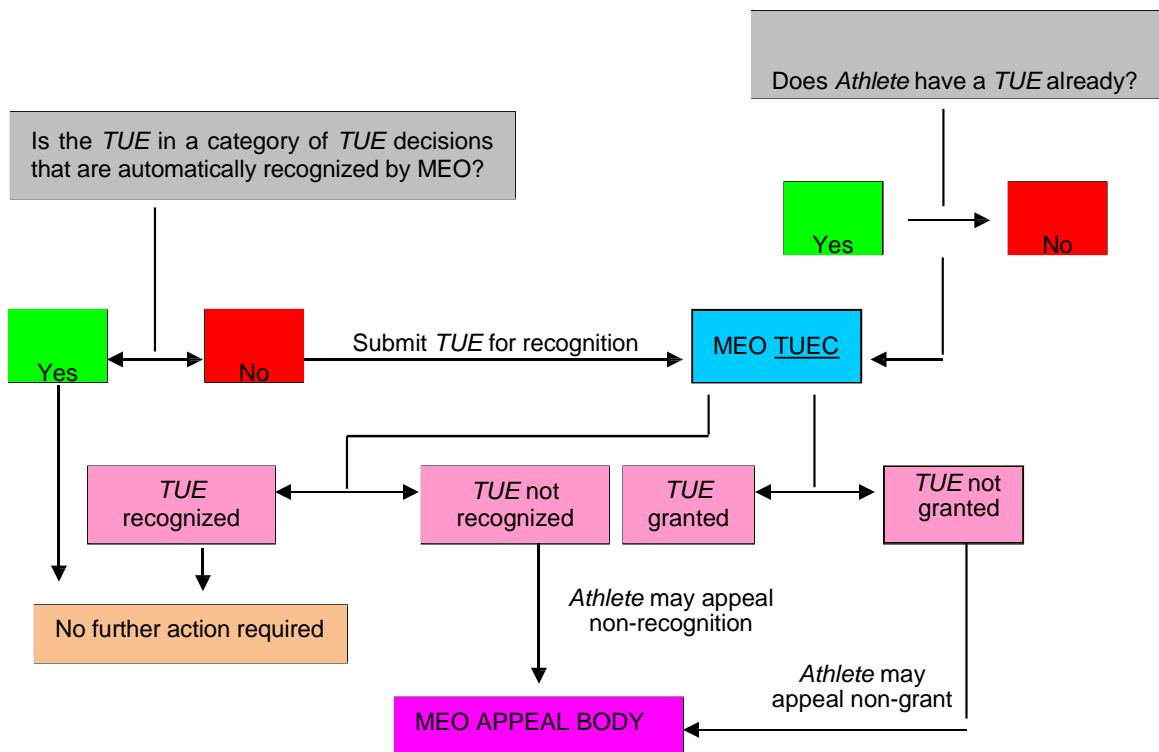



3. TUE Procedure if Athlete is an International-Level Athlete (and so subject to the International Federation's TUE requirements) when need for TUE arises

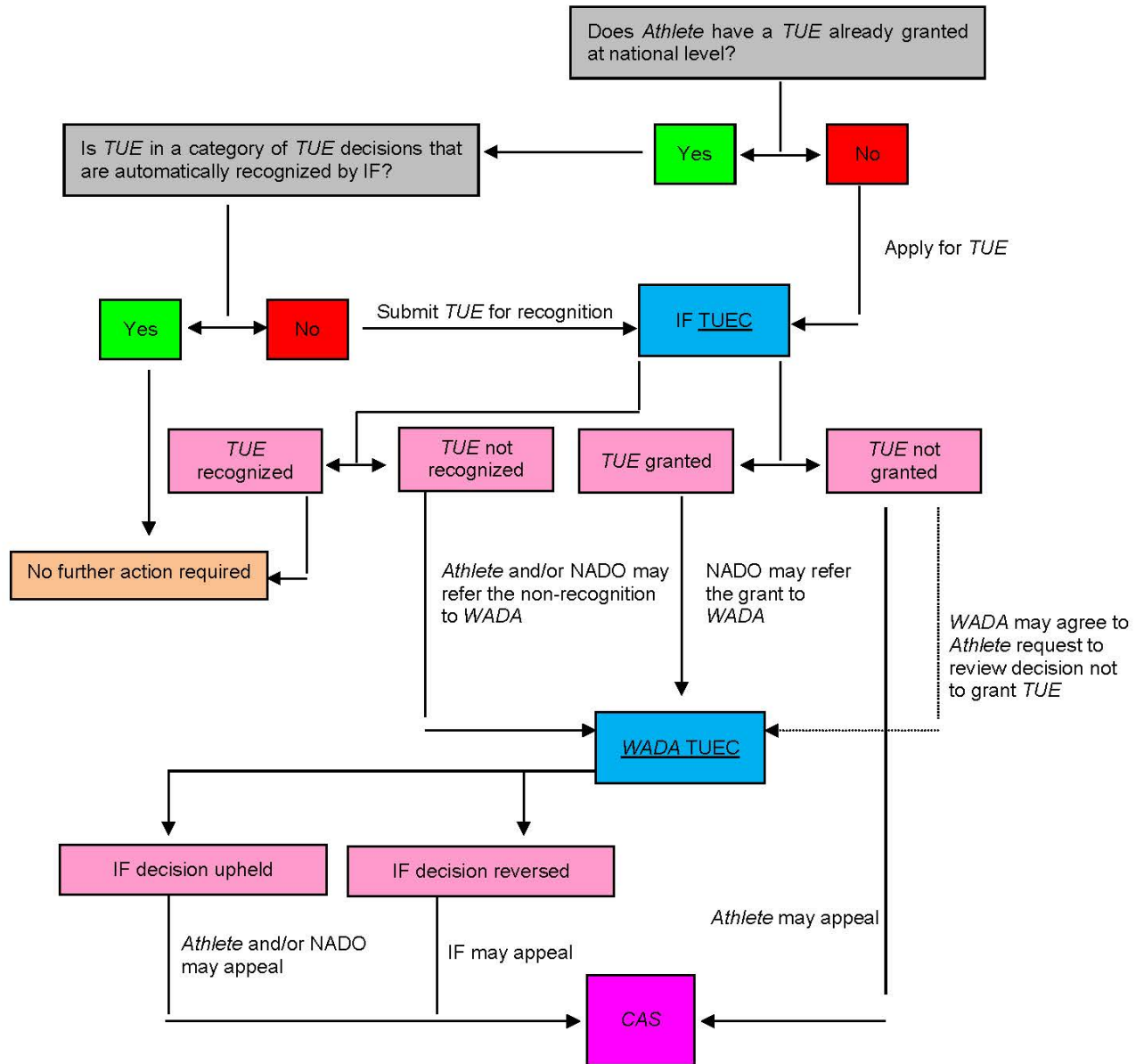



# THERAPEUTIC USE EXEMPTION (TUE)



## APPLICATION FORM

Schedule 3b

World Rugby fax: +353 1 2409 289

e-mail: TUE@worldrugby.org

In accordance with Section 4 of the WADA International Standard for Therapeutic Use Exemptions and World Rugby Regulation 21.4.4, any Player who wishes to apply for the use of a Prohibited Substances or Prohibited Method to treat a legitimate medical condition must apply to the relevant Therapeutic Use Exemption Committee (TUEC) via their national Union.

### SECTION A - Player Information - PLEASE PRINT CLEARLY IN CAPITALS

<b>First Name:</b> _____	<b>Surname:</b> _____	<b>Date of Birth:</b> ____ / ____ / ____
<b>Gender:</b> Male <input type="checkbox"/> Female <input type="checkbox"/>	<b>Contact Telephone Number - Mobile:</b> <input type="text"/>	
<b>National Union and level:</b> _____ <small>(i.e. Nat 15's Squad/7's/U21's etc)</small>	<b>Team/Club:</b> _____	

### SECTION B - Notifying Medical Practitioner and Medical Information

<b>Name:</b> _____	<b>Medical Specialty:</b> _____	
<b>Business Address:</b> _____		
<b>Telephone Number - Business:</b> <input type="text"/>	<b>Fax Number:</b> <input type="text"/>	<b>Telephone Number - Mobile:</b> <input type="text"/>
<b>Email:</b> _____		
<b>Diagnosis with sufficient medical information (see note 1):</b> _____ _____		
<b>Has the national Unions Chief Medical Officer / Doctor been notified of this application?</b> Yes <input type="checkbox"/> No <input type="checkbox"/>		

### SECTION C - Medical Details

<b>Prohibited Substance – Generic Name</b>	<b>Dose of Administration</b>	<b>Route of Administration</b>	<b>Frequency of Administration</b>
1.			
2.			

**Intended duration of treatment:** Once only  Emergency  Weeks  Months  Years

**If a permitted medication can be used to treat the medical condition, provide clinical justification for requested use of prohibited medication:**  
\_\_\_\_\_

### SECTION D - Medical Practitioner's Declaration

I, ..... certify that the above mentioned treatment is medically appropriate and that the use of alternative medication not on the Prohibited List would be unsatisfactory for this condition.

**Signature of Medical Practitioner:** \_\_\_\_\_ **Date:** \_\_\_\_ / \_\_\_\_ / \_\_\_\_

### SECTION E -- Previous or Current TUE Applications

**Have you submitted any previous TUE application:** Yes  No  **What date?:** \_\_\_\_ / \_\_\_\_ / \_\_\_\_

**If Yes, for what substance/s?** \_\_\_\_\_

**TUE Body who provided TUE Decision:** \_\_\_\_\_ **TUE Decision:** Attach copy of previous TUE application and Certificate of Approval if for same Prohibited Substance

# THERAPEUTIC USE EXEMPTION (TUE)



## APPLICATION FORM

Schedule 3b

World Rugby fax: +353 1 2409 289

e-mail: TUE@worldrugby.org

### SECTION F - Player's Declaration

I, ..... certify that the information under Section A & B is accurate and that I am requesting approval to use a Prohibited Substance or Method from the WADA Prohibited List. I authorise the recording (whether electronically or otherwise) and/or storage by release of personal medical information to the Anti-Doping Organisation (including without limitation its TUEC and any external expert consulted by the TUEC), relevant Tournament Organisers as well as to WADA staff and to the WADA TUEC (including without limitation any external expert consulted by the TUEC) under the provisions of the Code. I understand that if I ever wish to revoke the right of the relevant TUEC or WADA TUEC (including without limitation any external expert(s) consulted by such TUEC) to obtain my health information on my behalf, I must notify my medical practitioner in writing of that fact. I also understand that if I withdraw my consent to the release of my personal medical information, I may not receive approval for a TUE or the renewal of an existing TUE, since no TUE can be granted or renewed without the disclosure of comprehensive medical data.

I am aware that an application for a TUE requires the processing (for example transmission, disclosure, use and storage) of all data pertaining to such application through relevant anti-doping administration/data management systems including but not limited to ADAMS\* to ensure harmonized, coordinated and effective anti-doping programs for detection, deterrence and prevention of doping. Signing this form will indicate that I have been so informed and that I give my express consent to such processing of data.

I understand and agree that my application for a TUE will only be considered following the submission in ADAMS or otherwise, by myself or by my Anti-Doping Organisation (ADO), of the present completed application form, as well as all relevant documents related to the application.

I understand and agree that my TUE related data will be made accessible through ADAMS and/or any other relevant anti-doping administration/data management system, to the authorized ADO, to WADA and to the ADO/WADA TUEC(s) (including without limitation any external expert consulted by such TUEC). I understand and agree that if a TUE is granted, such TUE and the related information will be stored electronically in ADAMS (and/or in any other relevant anti-doping administration/data management system) for a minimum period of 10 years, the period of 10 years being the period within which an action can be commenced following a violation of an anti-doping rule contained in the WADA Code/World Rugby Regulation 21.

WADA, ADOs and TUECs (and any external expert consulted by the relevant TUEC) will not disclose any of my TUE related information beyond those persons within their organisation with a need to know for doping control purposes according to the Code (and to any external expert consulted by the relevant TUEC as appropriate).

I understand that if I believe that my personal information is not used in conformity with this consent and the International Standard for the Protection and Privacy and Personal Information I can file a complaint to WADA or CAS.

#### RELEASE

I hereby release WADA as well as ADOs and TUECs and any external expert consulted by a TUEC from all claims, demands, liabilities, damages, costs and expenses that I may have arising in connection with the processing of my TUE related data through ADAMS and/or any other relevant anti-doping administration/data management system.

#### WITHDRAWAL OF CONSENT

I understand that I may at any time revoke my consent for the processing of my TUE related data through ADAMS and/or any other relevant anti-doping administration/data management system. I also understand that as a consequence of such withdrawal of consent, I will not receive approval for a TUE or a renewal of an existing TUE.

**Player's Signature:** \_\_\_\_\_

**Date:** \_\_\_\_ / \_\_\_\_ / \_\_\_\_

**Parent's/Guardian's Signature:** \_\_\_\_\_

**Date:** \_\_\_\_ / \_\_\_\_ / \_\_\_\_

*(if a Player is a minor a parent or guardian shall sign together with or on behalf of the Player)*

*(Day/Month/Year)*

\* ADAMS is the Anti-Doping Administration and Management System, which has been developed to enable athletes and anti-doping organisations to enter and share data related to doping control. ADAMS is an on-line, web-based system, which allows restricted sharing of data only with those organisations with the right to access such data in accordance with the World Anti-Doping Code.

### SECTION G - Application Notes

*Note 1 Evidence confirming the diagnosis shall be attached and forwarded with this application. The medical evidence should include a comprehensive medical history and the results of all relevant examinations, laboratory investigations and imaging studies (where applicable). Copies of the original reports or letters should be included where possible. Evidence should be as objective as possible in the clinical circumstances and in the case of non-demonstrable conditions independent supporting medical opinion will assist this application.*

*WADA maintains a series of guidelines to assist physicians in the preparation of complete and thorough TUE applications. These TUE Physician Guidelines can be accessed by entering the search term "Medical Information" on the WADA website: <https://www.wada-ama.org>. The guidelines address the diagnosis and treatment of a number of medical conditions commonly affecting athletes, and requiring treatment with prohibited substances.*

### World Rugby TUEC Contact Details

World Rugby, World Rugby House, 8-10 Lower Pembroke Street, Dublin 2, Ireland

**Tel:** +353 1 2409 212 **Fax:** +353 1 2409 289 **Email:** [tue@worldrugby.org](mailto:tue@worldrugby.org)

INCOMPLETE OR ILLEGIBLE APPLICATIONS WILL BE RETURNED AND WILL NEED TO BE RESUBMITTED.

STRICTLY CONFIDENTIAL

**SCHEDULE 4. ACKNOWLEDGMENT AND AGREEMENT FORM**

I, ..... of .....

Union/Club/Rugby Body hereby acknowledge and agree as follows:

1. I have received and had an opportunity to review the World Rugby [other] Anti-Doping Rules.
2. I consent and agree to comply with and be bound by all of the provisions of the World Rugby [other] Anti-Doping Rules, including but not limited to, all amendments to the World Rugby [other] Anti-Doping Rules and all International Standards incorporated in the World Rugby [other] Anti-Doping Rules.
3. I acknowledge and agree that the World Rugby [other] has jurisdiction to impose sanctions as provided in the World Rugby [other] Anti-Doping Rules.
4. I also acknowledge and agree that any dispute arising out of a decision made pursuant to the World Rugby Anti-Doping Rules, after exhaustion of the process expressly provided for in those Regulations, may be appealed exclusively as provided in Regulation [21.13] [\*Appeals] to an appellate body for final and binding arbitration, which in the case of International-Level Players [others] is the Court of Arbitration for Sport.
5. The governing law of the appeal heard by the Court of Arbitration for Sport shall be English law.
6. I acknowledge and agree that the decisions of the arbitral appellate body referenced above shall be final and enforceable.
7. I agree that I will submit a Therapeutic Use Exemption form if I am required to do so under the World Rugby [other] Anti-Doping Rules;
8. I agree that my personal anti-doping data relating to the Doping Control process (including test distribution planning, Sample collection and handling, laboratory analysis, result management, hearings and appeals), Therapeutic Use Exemption and/or player whereabouts can be processed (for example transmitted, disclosed, used and/or stored) by and amongst my [Union / club / rugby body], World Rugby, Member Unions, the World Anti Doping Agency (WADA), National Anti Doping Agencies and/or other Anti Doping Organisations (as applicable) in electronic form including but not limited to as part of the ADAMS<sup>1</sup> database system.

---

<sup>1</sup> ADAMS is the Anti-Doping Administration and Management System which has been developed to enable athletes and anti-doping organisations to enter and share related to doping control. ADAMS is an on-line, web-based system, which allows restricted sharing of data only with those organisations with the right to access such data in accordance with the World Anti-Doping Code.

9. I have read and understand this Acknowledgement and Agreement.

Date: .....

Print Name: .....  
*(Last Name, First Name)*

Date of Birth: .....  
*(Day/Month/Year)*

Signature: .....  
*(or, if a minor, signature of legal guardian)*

\*This form may need to be modified for local use



## SCHEDULE 5. PLAYER INFORMATION NOTICE – DATA PRIVACY

### Doping Control-related Data

1. In the context of Doping Control activities you will be asked to sign a “Player Consent Form” for the processing of Doping Control-related data. This Information Notice explains in more detail how your Doping Control-related data will be used and processed to ensure harmonised, coordinated and effective anti-doping programmes for detection, deterrence and prevention of doping. The Player Consent Form should be read in conjunction with this Information Notice.

### Categories of Data

2. Your Doping Control-related data is any and all data with respect to the Doping Control process related to you (including test distribution planning, Sample collection and handling, laboratory analysis, results management, hearings and appeals), Therapeutic Use Exemptions and whereabouts.
3. The laboratory analysis results may include, without limitation: detection of a Prohibited Substance, its Metabolites or Markers or any evidence of use of a Prohibited Method identified on the Prohibited List; detection of the presence of other substances not included on the Prohibited List as may be directed by WADA pursuant to a monitoring programme described in Article 4.5 of the World Anti-Doping Code; longitudinal profiling of haematological parameters such as haemoglobin and red blood count over a specified period of time as well as testosterone/epitestosterone ratio; and/or results from other tests that may be developed in the future to identify the presence of Prohibited Substances or Prohibited Methods.
4. Some of your Doping Control-related data may constitute protected personal data under applicable national data protection or privacy laws where you reside.

### Responsibility

5. Your Doping Control-related data will be collected by an Anti-Doping Organisation (including without limitation World Rugby) acting pursuant to Regulation 21 and/or the Code or equivalent anti-doping rules (“the Testing Authority”), or through an authorised collection authority and/or results management authority. The Testing Authority will be responsible for protecting your information in accordance with its local laws and regulations, the WADA International Standard on the Protection of Privacy and Personal Information and Regulation 21 and/or the Code or equivalent anti-doping rules.

6. The Testing Authority will use a data-management system (which may be in electronic form including but not limited to the ADAMS<sup>1</sup> system) to process and manage, including disclose to authorised recipients, your Doping Control-related data.
7. You will be responsible for ensuring that all information which you provide or that is provided on your behalf by other parties, such as your Union, is accurate and up to date, including with respect to your whereabouts. Please note that failure to provide and/or update accurate whereabouts information is likely to constitute an anti-doping rule violation, whether the failure is intentional or negligent. If you are provided with a password to access the data-management system you will be responsible for keeping this password confidential at all times. Should you inadvertently or otherwise disclose such password you should contact the Testing Authority immediately.

### **Disclosures**

8. Your Doping Control-related data will, where appropriate, be made available to authorised Anti-Doping Organisations, in accordance with Regulation 21 and/or the Code or equivalent anti-doping rules, to enable them to administer their anti-doping programmes. These Anti-Doping Organisations may include, without limitation, National Anti-Doping Organisations, international or national sporting federations including without limitation World Rugby and Unions, Major Event Organisations and National Olympic Committees. Where this occurs, such Anti-Doping Organisations will be responsible for protecting your information in accordance with their local laws and regulations, the WADA International Standard on the Protection of Privacy and Personal Information and Regulation 21 and/or the Code or equivalent anti-doping rules.
9. Your Doping Control-related data will also be made available, in part, to WADA, which will need to process certain information in order to fulfil its obligations and responsibilities under the Code. In such case WADA will be responsible for protecting your information in accordance with its local laws and regulations, the WADA International Standard on the Protection of Privacy and Personal Information and the Code.
10. WADA accredited laboratories will need to receive your Samples and possibly other data relating to you; however, such laboratories will only be provided with de-identified, key-coded data and Samples that will not enable the laboratories to identify you.
11. The Anti-Doping Organisations, WADA and WADA accredited laboratories will process your Doping Control-related data only for the purpose of ensuring harmonised, coordinated and effective anti-doping programmes.

---

<sup>1</sup> ADAMS is the Anti-Doping Administration and Management System which has been developed to enable Players and Anti-Doping Organisations to enter and share Doping Control-related data. ADAMS is an on-line, web-based system, which allows restricted sharing of data only with those organisations with the right to access such data in accordance with Regulation 21 and/or the Code or equivalent anti-doping rules.

12. Anti-Doping Organisations, WADA, and WADA accredited laboratories will not disclose any of your Doping Control-related data other than to those persons within their organisation who require it for Doping Control purposes. Each of the organisations accessing and using any of your Doping Control-related data may only do so in order to fulfil their responsibilities and obligations arising under Regulation 21 and/or the Code or equivalent anti-doping rules, which primarily involve the establishment and maintenance of anti-doping programmes and ensuring appropriate information sharing as provided for under Regulation 21 and/or the Code or equivalent anti-doping rules.

### **International Transfers**

13. Your Doping Control-related data may be made available to persons or parties, including WADA and Anti-Doping Organisations, located outside of the country where you reside. In some other countries, data protection and privacy laws may not be equivalent to those in your own country.

### **Your Rights**

14. You may have certain rights under applicable laws and/or the WADA International Standard on the Protection of Privacy and Personal Information in relation to your Doping Control-related data, including rights to access and/or correct any inaccurate data, and remedies and rights of redress for any unlawful processing of your Doping Control-related data.
15. To the extent that you have any concerns about the processing of your Doping Control-related data you may consult with the Testing Authority, WADA ([www.wada-ama.org](http://www.wada-ama.org)), your Union and/or your National Anti-Doping Organisation, as appropriate.

### **Security**

16. Your Doping Control-related data may be held in electronic form including but not limited to ADAMS. ADAMS is hosted in data centres located in Canada and maintained by WADA on behalf of Anti-Doping Organisations using ADAMS. Strong technological, organisational and other security measures have been applied to ADAMS to maintain the security of the data it contains. In addition, WADA and Anti-Doping Organisations have put in place internal and contractual provisions to protect the confidentiality of your data.

### **Data Retention**

17. It may be necessary to retain certain of your Doping Control-related data in ADAMS (or other relevant administration/management system) for a minimum period of ten years. The period of ten years represents the time period within which an action may be commenced for an anti-doping rule violation under the Code, Regulation 21 and/or equivalent anti-doping rules. Your whereabouts information, however, will be retained for a much shorter period (approximately 18 months).

### **Right to Object**

18. You understand that you may have rights to object to the processing of your Doping Control-related data, although in that event, and as noted above, it still may be necessary for the Testing Authority and WADA to continue to process (including retain) certain parts of your Doping Control-related data to fulfil obligations and responsibilities arising under Regulation 21 and/or the Code or equivalent anti-doping rules and applicable laws.
19. You understand that objecting to disclose your Doping Control-related data, or objecting to the processing of your Doping Control-related data, may make anti-doping testing and procedures in accordance with Regulation 21 and/or the Code or equivalent anti-doping rules, as applicable, and the International Standards impossible. In such case your objection could be equivalent to an anti-doping rule violation which may exclude you from further participation in the Game, and may result in disciplinary or other sanctions being imposed upon you, such as disqualification from competitions in which you are scheduled to participate or the invalidation of results arising from prior competitions.

### **Release**

20. By signing the Player Consent Form you release the Testing Authority (and World Rugby, where World Rugby is not the Testing Authority), WADA, and relevant Anti-Doping Organisations, from all claims, demands, liabilities, damages, costs and expenses that you may have arising in connection with the processing of your Doping Control-related data through ADAMS, and/or any other relevant administration/management system.

## REGULATION 22. STANDARD RELATING TO THE USE OF ARTIFICIAL RUGBY TURF

### 22.1 Definitions

For the purposes of this Regulation 22 the terms below shall have the following meanings assigned to them:

**Artificial Rugby Turf** means an artificial playing surface for training and playing the Game, which meets the requirements of the World Rugby Artificial Rugby Turf Performance Specification and Regulation 22.

**Field Tests** means testing of an installed artificial playing surface(s) by a Test Institute in accordance with the World Rugby Artificial Rugby Turf Performance Specification.

**Laboratory Tests** means tests conducted on sample(s) of artificial playing surfaces by a Test Institute in accordance with the World Rugby Artificial Rugby Turf Performance Specification.

**Manufacturer** means a manufacturer of artificial playing surfaces intended for use in rugby.

**Test Institute** means an entity approved by World Rugby to provide Laboratory Tests.

**World Rugby Artificial Rugby Turf Performance Specification** means the World Rugby standard relating to Artificial Rugby Turf which is available on the World Rugby website at [www.worldrugby.com](http://www.worldrugby.com).

**World Rugby Artificial Turf Expert Group** means the group appointed by World Rugby to be responsible for the management of the World Rugby Artificial Rugby Turf Performance Specification.

**World Rugby Preferred Turf Producer** means any World Rugby accredited entity which is responsible for the manufacture, construction, installation and maintenance of Artificial Rugby Turf surfaces.

### 22.2 Introduction

Technology in the area of artificial playing surfaces has improved over time and artificial playing surfaces are widely used including in rugby. World Rugby has produced the World Rugby Artificial Rugby Turf Performance Specification to set a minimum standard for artificial playing surfaces which may be used in rugby. The World Rugby Artificial Rugby Turf Performance Specification stipulates the testing and approval procedures which Manufacturers and other entities involved in the installation of artificial playing surfaces must comply with in order for their products to be approved for use in rugby. The Game may not be played on any artificial surface which does not meet the World Rugby Artificial Rugby Turf Performance Specification, the requirements of Regulation 22 and Law 1 of the Laws of the Game. The World Rugby Artificial Rugby

Turf Performance Specification will be amended over time as technology and research evolves in the area of artificial playing surfaces.

### 22.3 Testing Protocol

The suitability of an artificial playing surface for rugby depends on the surface layer, the preparation of the sub-base and the composition of the existing sub-soil. Therefore, testing of the surface will necessarily involve Laboratory Tests and Field Tests. A surface can only be certified as meeting the World Rugby Artificial Rugby Turf Performance Specification upon the successful completion of both the Laboratory Tests and Field Tests. Accordingly, only installed Artificial Rugby Turf surfaces which have been tested and proved to meet the World Rugby Artificial Rugby Turf Performance Specification will be permitted for use in rugby.

<b>Step 1</b>	Manufacturer and/or World Rugby Preferred Turf Producer submit product sample to Test Institute
<b>Step 2</b>	Product sample subjected to the Laboratory Tests - if it passes it moves to step 3
<b>Step 3</b>	A surface comprising the material of the product sample which satisfied the Laboratory Tests is installed
<b>Step 4</b>	The installed surface undergoes the Field Tests
<b>Step 5</b>	If the surface passes the Field Tests it is certified as meeting the World Rugby Artificial Rugby Turf Performance Specification by the Union

### 22.4 World Rugby Artificial Rugby Turf Performance Specification Tests

#### 22.4.1 Laboratory Tests

Manufacturers and/or World Rugby Preferred Turf Producers must submit an artificial playing surface sample of approximately 2.0 metres x 2.0 metres of each product type/model proposed for classification as an Artificial Rugby Turf to a Test Institute. Successful completion of the Laboratory Test phase will enable progression to Field Tests.

#### 22.4.2 Field Tests

- (a) Field Tests are carried out upon the artificial playing surface once it has successfully completed the Laboratory Tests and has been installed.
- (b) The date set for the Field Tests will take into account that artificial playing surfaces often require some time to settle following installation. Field Tests will ordinarily be conducted by the Test Institute within three months of installation of the artificial playing surface.

- (c) Taking into consideration that the Laboratory Tests may take several weeks and that there will be a gestation period before the Field Tests may occur, the final approval of an artificial playing surface may take up to six months (if no re-testing is required).

### 22.4.3 Test Evaluations

There are three basic categories of test which determine the suitability of an artificial playing surface for rugby. These may be broadly identified as:

1. The reaction of a ball to the artificial playing surface (Ball/Surface Interaction)
2. The reaction of a Player to the artificial playing surface (Player/Surface Interaction)
3. The resistance of the artificial playing surface to wear and tear, and the environment (Durability)

The World Rugby Artificial Rugby Turf Performance Specification sets out that the testing process as a minimum will include:

#### *Laboratory Tests*

- (i) Identification
- (ii) Durability
- (iii) Climatic Resistance
- (iv) Player/Surface Interaction
- (v) Ball/Surface Interaction

#### *Field Tests*

- (i) Construction (Slope, Evenness, Base Permeability)
- (ii) Player/Surface Interaction
- (iii) Ball/Surface Interaction
- (iv) Identification

### 22.5 Test Procedures

The test procedures and methods are outlined in the World Rugby Artificial Rugby Turf Performance Specification and may vary from time to time as determined by the World Rugby Artificial Surfaces Expert Group. The World Rugby Artificial Surfaces Expert Group is appointed by the World Rugby to monitor developments in technology with respect to Artificial Rugby Turf and amend the World Rugby Artificial Rugby Turf Performance Specification as appropriate.

### 22.6 Inherent Dangers

Rugby is a contact sport and there are inherent dangers in playing the Game on any surface including Artificial Rugby Turf.

### **22.7 Modifications**

Any minor modifications in the profile or composition of an artificial playing surface which has passed the Laboratory Tests must be submitted to a Test Institute together with relevant evidence that the surface continues to satisfy the requirements of the World Rugby Artificial Rugby Turf Performance Specification. Any significant change will require a complete re-evaluation of the surface by a Test Institute.

### **22.8 Maintenance**

The party acquiring and/or responsible for the maintenance and/or management of the Artificial Rugby Turf surface must demonstrate to the Test Institute on a periodic basis as required by the Union and/or World Rugby, that it is maintaining the Artificial Rugby Turf surface such that it continues to meet the World Rugby Artificial Rugby Turf Performance Specification, the requirements of Regulation 22 and Law 1.1 of the Laws of the Game.

### **22.9 Continued Testing**

Each Artificial Rugby Turf surface will be re-tested by a Test Institute every two years during its lifetime to ensure that through an appropriate maintenance regime it continues to meet the World Rugby Artificial Rugby Turf Performance Specification, the requirements of Regulation 22 and Law 1.1 of the Laws of the Game.

### **22.10 Contact**

World Rugby Technical Services Department,  
World Rugby,  
World Rugby House,  
8-10 Pembroke Street,  
Dublin 2,  
Ireland

**t:** + 353 1 240 9200

**f:** + 353 1 240 9201

**w:** [www.worldrugby.org](http://www.worldrugby.org)



## APPENDIX 1. ADDITIONAL REQUIREMENTS FOR INSTALLATION AND USE OF ARTIFICIAL RUGBY TURF SURFACES

Rugby Bodies, Clubs, organisations or other entities seeking to install an Artificial Rugby Turf surface must adhere to the following conditions in addition to the testing and approval regime established by Regulation 22 and the World Rugby Artificial Rugby Turf Performance Specification:

1. Permission to install or use an artificial playing surface must be sought in writing in advance of installation or the first use from the Union in whose territory the surface is intended to be installed or used. The Union must ascertain:
  - (a) in the case of a request for installation, that the Union has received a report of the Test Institute confirming that the artificial playing surface has passed the Laboratory Tests; or
  - (b) in the case of a request for use, that the Union has received a report of the Test Institute that the artificial playing surface has passed the Field Tests and has been certified in accordance with the World Rugby Artificial Rugby Turf Performance Specification.

Where the artificial playing surface has met the World Rugby Artificial Rugby Turf Performance Specification, the requirements of Regulation 22 and Law 1.1 of the Laws of the Game, the Union shall grant such permission. Where a Union is the party seeking to install or use an artificial playing surface then permission shall be sought from World Rugby.

2. The permission of the Union pursuant to Section 1 above shall be granted for a period of two years, following which the Artificial Rugby Turf surface shall be re-tested by a Test Institute. Where the Artificial Rugby Turf surface continues to meet the World Rugby Artificial Rugby Turf Performance Specification, the requirements of Regulation 22 and Law 1.1 of the Laws of the Game, the Union shall grant permission for use of the surface for a further period of two years. The Artificial Rugby Turf surface shall then be re-tested by a Test Institute every two years of its lifetime and Unions shall grant permission for use of the surface for further periods of two years accordingly.
3. This permission does not constitute and/or imply an endorsement by the granting Union or World Rugby of the artificial playing surface(s) concerned.
4. During the period for which permission is granted, the Artificial Rugby Turf surface may be used for the playing of the Game including International Matches.
5. The World Rugby Preferred Turf Producer and/or entity contracted to install the artificial playing surface shall be responsible for the supply of equipment and training in relation to maintenance of the artificial playing

surface. The World Rugby Preferred Turf Producer and/or entity contracted to install/maintain the artificial playing surface shall indemnify and hold harmless World Rugby and its associated companies and the Union, and its and their officers, employees and agents from and against all demands, claims, legal actions, damages, costs (including without limitation, legal costs and the fees of any expert witness(es) incurred in connection with any action(s) or proceeding(s)), loss, interest, or expenses in connection with any injury sustained by a Player as a result of the surface and/or any failure to comply with the World Rugby Artificial Rugby Turf Performance Specification and/or any other act or omission by or on behalf of the World Rugby Preferred Turf Producer and/or Manufacturer and/or installer of the artificial playing surface and/or the entity responsible for maintenance of the artificial playing surface (as the case may be).

6. The World Rugby Preferred Turf Producer and/or entity contracted to install/maintain the Artificial Rugby Turf surface shall have in place and shall maintain public liability insurance cover with a reputable insurer to meet any claim that may arise in the sum of £5 million sterling save where a particular Union shall demonstrate to the satisfaction of World Rugby that its national government has in place a comprehensive, no-fault, government-funded public liability scheme which covers, without limitation, any and all treatment and compensation arising from any injury occasioned through participation in rugby Matches.
7. The Union in whose territory the Artificial Rugby Turf surface is to be used should ensure that all participants playing on the Artificial Rugby Turf surface understand and appreciate that there are inherent dangers in participating in the sport on any surface including Artificial Rugby Turf.
8. The Union shall log injuries sustained by Players participating on the Artificial Rugby Turf surface.
9. World Rugby may request sample injury surveys and such further and supplemental information as it requires from Unions to monitor the ongoing safety of Artificial Rugby Turf. Unions requested to undertake such surveys shall not unreasonably withhold permission and will make best endeavours to facilitate the surveys and requests for information. In response to such requests Unions shall use the form attached (Appendix 2) modified as appropriate. It is the responsibility of the Union concerned to obtain the requisite consents, in accordance with local law, of Players, coaches and medical personnel, as appropriate, for the collection of personal information and provision of such information to the relevant Union, World Rugby, its associated companies and any other entity designated by World Rugby for use in connection with Regulation 22 and the World Rugby Artificial Rugby Turf Performance Specification.
10. Manufacturers shall not in any way seek or promote any association with World Rugby. World Rugby Preferred Turf Producers shall only be allowed to associate with World Rugby to the extent granted in their agreement with World Rugby.

- 
11. World Rugby shall be entitled to impose such further conditions as it considers appropriate in the best interests of Players and the Game.

---

**APPENDIX 2. ARTIFICIAL RUGBY TURF INJURY  
INFORMATION FORM**

Match: ..... versus .....

or

Training: Yes  No  Venue: .....

Date/KO Time: ..... Referee: .....

Conditions: .....

Type of Surface/Manufacturer/World Rugby Preferred Turf Producer: .....

Player Name: ..... Position: .....

Nature and Cause of Injury: .....

.....  
.....  
.....

Attention Required: .....

.....  
.....  
.....

Period of Time Player Unable to Play Rugby: .....

Attending Doctor Name: .....

Signed by Union Medical Officer: .....

*(Print Name in Block Capitals)*

Confirmation by Union official of consent of Player/coach/medical officer to personal information sharing:

Signed: ..... Date: .....

Name: .....

## REGULATION 23. INSURANCE

### Definitions

For the purposes of this Regulation 23 the terms below shall have the following meanings assigned to them:

**Career-Ending Injury** means an injury to a Player which wholly and continually prevents him from participating in the Game and where no recovery to permit the Player to resume participating in the Game is foreseeable;

**Catastrophic Injury** means an injury to a Player which wholly and continually prevents him from participating in any and every occupation including the Game and where no recovery is foreseeable;

**Emoluments** means Guaranteed Payments less any amounts which are or will be received by a Player from his Primary Employer, if that Primary Employer is a Rugby Body or Club, during the Player's period of incapacitation from playing the Game so as to represent the real economic loss in each case with respect to Guaranteed Payments;

**Guaranteed Payments** means the actual payments guaranteed to a Player for a one-year period from the date of the injury in respect of playing the Game by a Rugby Body or Club where that Rugby Body or Club is the Player's Primary Employer;

**International Duty** means representing, playing for, training and/or preparing with a senior National Representative Team and/or a National Squad;

**Medical Expenses** means the actual cost of medical expenses incurred in treating an injury to a Player, excluding, without limitation, pioneering or alternative treatments, international travel for treatment other than travel to the Player's home country and any other expenses above the ordinary cost of the necessary treatment. World Rugby will have the final decision in respect of any dispute in relation to the foregoing;

**Primary Employer** means an employer for whom a Player is required, pursuant to a written agreement, to provide services for a minimum of 75% of his Working Time;

**Temporary Total Disablement** means an injury to a Player which temporarily and totally prevents him from participating in the Game but is not a Catastrophic Injury or Career-Ending Injury; and Temporarily Totally Disabled shall be construed accordingly; and

**Working Time** means the total time a Player is available to provide services whether such services are provided to the Primary Employer or otherwise.

### **23.1 Liability for Players other than when on International Duty**

- 23.1.1 Players or their Primary Employers are responsible for and shall have in place appropriate financial arrangements or insurance to cover the Player in respect of losses and expenses incurred as a result of injury sustained whilst participating in the Game at any level and at all times other than when the Player is on International Duty.
- 23.1.2 If the Primary Employer of the Player is a Rugby Body or Club then it will be responsible for having in place the appropriate financial arrangements or insurance to cover the Player whilst participating in the Game at any level and at all times other than when the Player is on International Duty. Such cover should include Medical Expenses, loss of Emoluments, Temporary Total Disablement, Career-Ending Injury and Catastrophic Injury incurred as a result of injury sustained whilst participating in the Game at any level and at all times other than when the Player is on International Duty.
- 23.1.3 If the Primary Employer of the Player is not a Rugby Body or Club then the Player shall be responsible for having in place the appropriate financial arrangements or insurance to cover the Player whilst participating in the Game at any level and at all times other than when the Player is on International Duty.

### **23.2 Liability for Players when on International Duty**

- 23.2.1 Unions are responsible for and shall have in place appropriate financial arrangements or insurance to cover each Player (and/or his Primary Employer as applicable) in respect of losses and expenses incurred as a result of injury sustained when such Player is on International Duty. Such financial arrangements and/or insurance cover should include Medical Expenses, loss of Emoluments, Temporary Total Disablement, Career-Ending Injury and Catastrophic Injury incurred as a result of injury sustained at the time that the Player is on International Duty.
- 23.2.2 The minimum financial limits and the terms and conditions of the cover to be provided pursuant to Regulation 23.2.1 shall be agreed as follows:
- (a) between the Union and the Player; or
  - (b) between the Primary Employer and the Player where applicable, save where the Union has exercised the right of release pursuant to Regulation 9 in which case the limits set out in Appendix 3 to Regulation 9 shall apply.

### **23.3 General Responsibilities of Unions and World Rugby**

- 23.3.1 World Rugby does not have, nor shall it accept, any responsibility and/or obligation in the event that the Primary Employer and/or the Player and/or the Union (as the case may be) fail to have appropriate financial arrangements or insurance to cover the Player pursuant to Regulation 23.2. For the avoidance of doubt World Rugby is not

---

responsible for arranging and/or monitoring appropriate financial arrangements and/or insurance cover under this Regulation 23.

- 23.3.2 In the interests of the welfare of Players and the reputation of the Game worldwide, World Rugby shall have the right to periodically review the financial arrangements or insurance that Unions have in place to cover Players on International Duty.
- 23.3.3 A Union shall if requested by any Player, Primary Employer, World Rugby or any other party having demonstrated to the satisfaction of World Rugby that it has a valid interest provide a certificate or other satisfactory evidence of the financial arrangements or insurance cover in place for any Player.
- 23.3.4 In the event that a Union does not satisfy the requirements of this Regulation 23 World Rugby may take such action as it considers appropriate.





---

**REGULATION 24. MATTERS NOT PROVIDED FOR**

Any Matters not provided for in these Regulations shall be dealt with by the Council.





**WORLD  
RUGBY™**

# SECTION 4

## GENERAL REGULATIONS OF WORLD RUGBY



---

## SECTION 4      **General Regulations of World Rugby**

### **1      Meetings**

- 1.1      Agenda Confidential
- 1.2      Public Announcement
- 1.3      Duration of Meetings
- 1.4      Voting
- 1.5      Minutes
- 1.6      Council Committees

### **2      Finance**

- 2.1      Bank Account
- 2.2      Union's Contributions
- 2.3      Accounting Records
- 2.4      Expenses

### **3      General**

- 3.1      Implementation
- 3.2      World Rugby's Handbook
- 3.3      Trade Marks
- 3.4      Copyright



## **1. Meetings**

### **1.1 Agenda**

A Union may decide as to whether or not it discloses proposals it has remitted to the Council, but remits from other Unions remain confidential.

### **1.2 Public Announcement**

Council shall procure that arrangements are in place to ensure timely and accurate announcements of and effect given to decisions made by Council.

### **1.3 Duration of Meetings**

A minimum of one day should normally be allowed for the Annual and Interim Meetings of the Council. The dates and venues shall be in accordance with Bye-Law 9.4.

### **1.4 Voting**

Under no circumstances shall voting by proxy be allowed at a Council Meeting.

### **1.5 Minutes**

Draft minutes of meetings shall be sent first to the Chairman of the Council and to the Chairman of any relevant Committees for amendment and/or comment. Thereafter the draft minutes shall be circulated by the Chief Executive Officer to Council representatives and to Member Unions. The Minutes of a meeting shall be approved at the Annual Meeting, and thereafter printed for circulation.

### **1.6 Council Committees**

Where a committee of the Council comprises a Representative from each Union represented on the Council and it is not possible for that representative to attend a meeting or meetings, his Union may appoint another person to take his place.

## **2. Finance**

### **2.1 Bank Account**

2.1.1 An Account shall be opened in the name of World Rugby and the bank shall be authorised to honour all cheques, transfers or other orders of payment drawn on such account if signed according to the foregoing:

- (i) by any 2 of the Chief Executive Officer, the Head of Finance, the Chairman or, Vice-Chairman and for amounts not higher than £5,000; or
- (ii) by two of the above persons excluding the Head of Finance for amounts in excess of £25,000.

- (iii) The CEO and Head of Finance shall be authorised to open additional bank accounts for World Rugby entities as considered necessary provided they accord with the Authority levels agreed by EXCO.

## **2.2 Union's Contributions**

- 2.2.1 Unions shall contribute on 1 January of each year a membership subscription which amount will be determined by the Council at its Interim Meeting.

## **2.3 Accounting Records**

Accounting records shall be opened and kept by a qualified person in such detail as to enable the World Rugby's income, expenditures and balance sheet to be properly prepared, analysed and audited.

## **2.4 Expenses**

- 2.4.1 Expenses include travel fares as well as reasonable expenses for accommodation, subsistence and communication while attending meetings.

- 2.4.2 Travel expenditures when on Council's business will be on the basis of "Business or Executive Class" in the case of air travel exceeding eight hours travel time and on the basis of "economy" fare for other travel. The World Rugby CEO has discretion to deviate from the eight hour policy on a case by case basis. Other expenses may be claimed in accordance with the expense policies set out in the World Rugby Handbook..

## **3. General**

### **3.1 Implementation**

Regulations adopted by the Council are to take effect immediately unless otherwise stated.

### **3.2 World Rugby's Handbook**

The World Rugby's Handbook for the year must include Instructions and Notes on the Laws of the Game.

### **3.3 Trade Marks**

No individual or organisation may reproduce the World Rugby's logo, which is a registered trade mark, without a formal licence from World Rugby. World Rugby may from time to time make available to Representatives free of charge certain articles of clothing bearing the World Rugby's logo and/or name. Articles may from time to time be available for purchase by Representatives from World Rugby.



### 3.4 Copyright

World Rugby is the sole and exclusive owner of the copyright in the Bye-Laws, Regulations Relating to the Game and the General Regulations.





**WORLD  
RUGBY™**

# SECTION 5

## TOURS AGREEMENT



---

## **SECTION 5 World Rugby Tours Agreement**

- 1. Definitions and Interpretations**
- 2. The Tour**
- 3. Leave**
- 4. Players Remaining Behind Owing to Illness or Injury**
- 5. Replacement of and Additional Players During The Tour**
- 6. Tour Organisation**
- 7. Travel, Accommodation, Vehicles and Tour Expenses**
- 8. Baggage**
- 9. Other Expenses**
- 10. Matches**
- 11. Match Officials**
- 12. Illegal and/or Foul Play and Misconduct**
- 13. Playing Kit and Team Uniform**
- 14. Training Venue Facilities and Equipment**
- 15. Familiarisation Visit**
- 16. Medical Arrangements**
- 17. Tickets**
- 18. Ceremonies and other Match Arrangements**
- 19. Anti-Doping**
- 20. Commercial Rules**
- 21. Security**

- 22. Media Rules**
  - 23. Delayed, Postponed, Abandoned and Cancelled Matches**
  - 24. Force Majeure**
  - 25. Dispute Resolution and Compliance**
  - 26. Limitations on Liability of the Host Union**
  - 27. Discipline**
  - 28. General Provisions**
  - 29. Acceptance**
- 
- Schedule 1. List of Matches, Venues and Kick-Off times
  - Schedule 2. Accommodation and Vehicle Provision
  - Schedule 3. Details of Visiting Unions' Medical Insurance Policy
  - Schedule 4. Disciplinary Procedures for Non-International Matches
  - Schedule 5. Minimum training facility and equipment requirements
  - Schedule 6. Minimum medical facilities, equipment and personnel
  - Schedule 7. Dispute resolution and compliance

## WORLD RUGBY TOURS AGREEMENT

Relating to the visit of the [\* ] Rugby Union  
 to [\* ] in [Date ]

### 1. Definitions and Interpretations

#### 1.1 The following terms, where used in this Agreement, shall have the following meanings assigned to them:

**CEO** means the World Rugby's Chief Executive Officer;

**Council** means the World Rugby's Executive Council which comprises representatives of Unions and Associations appointed as provided in the Bye-Laws and who comprise the committee that has the ultimate and supreme legislative authority in respect of the affairs of World Rugby;

**Excess Baggage** means any baggage or personal effects of the Tour Party, the conveyance or transportation of which is not accepted without an additional charge by any form of transport regulations. Official team kit and equipment, medical and physiotherapy equipment or supplies are excluded from this definition but other personal property and playing equipment belonging to the Tour Party and/or any member of the Tour Party such as scrummaging machines etc. are included in this definition;

**Event of Force Majeure** means any circumstance(s) not reasonably foreseeable at the date of this Agreement arising from or attributable to acts, events, omissions or accidents which are beyond the reasonable control of the affected party including without limitation any strike or lock out or industrial action of whatever nature (which is not due to any party to this Agreement including any Tour Party Member or any associates, agents, representatives or employees or such party), accidental fire, storm or tempest, act of God, explosion, sabotage, flood, earthquakes, subsidence, epidemic or other natural physical disaster, structural damage, failure of power supplies, riot, crowd disorder, act of terrorism, war, civil commotion or any legislation, regulation, ruling or omissions (including failure to grant any necessary permissions) of any relevant government, court or any competent national or international authority;

**Game** means rugby football played in accordance with the Laws of the Game;

**The Host Union** means the [\* ];

**Illness** means any medical and/or dental disability;

**Injury** means any physical disability;

**International Match** means a match played between National Representative Teams selected by Unions;

**Match** means a Game in which two teams compete against each other;

**Match Officials** means the referee and two touch judges, the fourth and fifth Match Officials and the Television Match Official;

**Medical** means medical and/or dental;

**National Representative Team** means a team selected by a Union to represent that Union;

**Outward Journey and Homeward Journey** means the travel between the point of departure which shall be [\* ] and the point of arrival which shall be [\* ] (“the Outward Journey”) and on the homeward journey between the point of departure, namely [\* ] and the point of arrival which shall be [\* ] (“the Homeward Journey”) with an authorised deviation via respectively by a route or routes selected by the [Visiting] [Host] Union [subject to agreement of] the [Visiting] [Host] Union;

**Regulations** means Regulations Relating to the Game binding on all Unions and Associations and which have been passed by the Council or which may hereafter be passed by the Council under the powers contained in the Bye-Laws;

**Team** means the players selected by the Visiting Union to represent the Visiting Union on the Tour and shall consist of not more than 36 players at any one time;

**The Tour** means the period from the date upon which the Tour Party commences the Outward Journey, the Visit and the date of return at the end of the Homeward Journey;

**The Tour Party** means the Team and The Tour Management which shall comprise up to a maximum of 46 persons;

**The Tour Management** means a Manager (hereinafter called “the Manager”) and any other appointed Tour Member who is not a member of the Team;

**Union** means every national Rugby Union for the time being in membership of World Rugby;

**The Visit** means the period from [\* to ] during which the Tour Party shall be in [\* ] for the Matches and social functions arranged by the Host Union;

**The Visiting Union** means the [\* ];

**World Rugby** means the association of Unions or Associations in membership of World Rugby in accordance with the Bye-Laws;



## 1.2 Interpretations

For the purposes of this Agreement and provided the context so permits

- (a) the singular shall include the plural and vice-versa;
- (b) any reference to natural persons includes references to any legal person or corporation;
- (c) the clause headings have been inserted for convenience only and shall not be taken into account in the interpretation of the Agreement;
- (d) references to clauses and schedules are references to clauses and schedules of this Agreement;
- (e) where any clause and/or potential breach of any clause of this Agreement is described as “material” then that shall not preclude other clauses and/or potential breaches not so described from being so classified.

## 2. The Tour

2.1 The Visiting Union agrees that it will undertake the Tour in accordance with the provisions of this Agreement and play the Matches at the venues and kick-off times set out in Schedule 1.

2.2 The Host Union agrees that it will host the Tour in accordance with the provisions of this Agreement and that it will field a team to play in the Matches at the venues and kick-off times set out in Schedule 1.

### 2.3 Tour Details

2.3.1 The Tour Party shall leave [ ] by a departure which will enable it to arrive in [ ] on or about the [ Date ] the first Match having been arranged to take place on [ Date ].

2.3.2 The Tour Party shall return by the first appropriate departure from [ ] to [ ] (or if a Deviation shall have been authorised, then by the first available appropriate departure) following upon the last Match in [ ].

2.3.3 The Host Union will be responsible for meeting the costs of a Tour Party of not more than 46 persons in accordance with the provisions of this Agreement. If the Visiting Union elects to travel with a Tour Party in excess of 46 persons the Host Union will use its reasonable endeavours to make arrangements for the extra persons consistent with the Tour Party however, for the avoidance of doubt subject to the provisions of this Agreement, any and all costs associated with additional Tour Members will be the sole responsibility of the Visiting Union. The Host Union will be responsible for meeting the costs of the Visiting Union from no earlier than seven clear days prior to the first Match of the Tour save in circumstances

where, despite the use of the Visiting Union's best endeavours, the Visiting Union can demonstrate that no scheduled inbound flight can be arranged that would facilitate arrival seven days prior to the first Match of the Tour in which circumstances only the Host Union will be responsible for such costs for eight clear days prior to the first Match of the Tour.

## **2.4 Alteration to Homeward Journey**

2.4.1 The Homeward Journey may be altered by the Visiting Union provided there are no consequential cost implications for the Host Union.

## **3. Leave**

3.1 No provision shall be made for any member of the Tour Party to be separated from the Tour Party during any part of the Tour, except in individual instances of Illness or Injury certified by the Doctor of the Visiting Union, or of leave of absence permitted at the discretion of the Manager of the Visiting Union with due notice given to the Host Union. The expenses of such leave shall be the responsibility of the Visiting Union and shall be agreed between the leaving member of the Tour Party and the Manager of the Visiting Union.

3.2 If a member of the Tour Party wishes to prolong his stay beyond the Visit, the Host Union shall have no liabilities, responsibilities or obligations in respect of any prolongation of stay whether agreed by it or otherwise.

## **4. Players Remaining Behind Owing to Illness or Injury**

4.1 If any member of the Tour Party is prevented by Illness or Injury (as verified by the Host Union Medical Director or his designee) from leaving with the rest of the Tour Party on the Homeward Journey, then on his departure the Host Union shall be liable for his travelling expenses to the point of departure for the Homeward Journey. The cost of his return passage by a route selected by the Visiting Union shall be paid by the Visiting Union. The Host Union shall not be liable for his hotel or other expenses for his extra stay but shall help facilitate arrangements for the extra stay.

## **5. Replacement of and Additional Players during the Tour**

5.1 If a member of the Team shall be found by the Visiting Union's Doctor to be unfit to play in the remainder of the Tour, the Visiting Union may replace such member subject to prior notice being given to the Host Union. The cost of the fares for the outward and homeward transportation of each such replacement shall be paid by the Visiting Union in accordance with the provision of Clause 7.1.1. All other expenses as provided for in Clause 7.1.2 hereof shall be paid by the Host Union subject always to the maximum Tour Party size of 46.

5.2 If owing to Injury or Illness the playing strength of the Team is in the opinion of the Visiting Union's Manager so reduced as to throw an undue burden on the other members of the Team, the Visiting Union may, on the recommendation of the Visiting Union's Manager, and with prior notice

being given to the Host Union, provide an additional player or players to join the Tour Party. The cost of the fares for the outward and homeward transportation of each such player shall be paid by the Visiting Union, but all other expenses as provided for in Clause 7.1.2 hereof shall be paid by the Host Union subject to the maximum Tour Party size of 46.

- 5.3** Any replacement player or additional player approved under sub-clause 5.2 shall be deemed to be a member of the Tour party for all purposes of this Agreement with effect from the commencement of his own outward journey.
- 5.4** When for any reason a player is replaced he shall cease to be a member of the Tour Party and will not be permitted to rejoin it.
- 5.5** If a dispute arises between the Host Union and Visiting Union over the replacement of players to the Team during the Tour, and the Host Union and Visiting Union are unable, within a reasonable time, to resolve the dispute, then either Union may refer the matter to the CEO, or his designee, for adjudication in accordance with Clause 25 of this Agreement.

## **6. Tour Organisation**

- 6.1** The Host Union shall make all appropriate arrangements for the Tour, other than the Outward Journey, deviations and the Homeward Journey, and shall control any items of expenditure for which the Host Union is liable as provided for and in accordance with the provisions of this Agreement.

### **Liaison Officer**

- 6.2** Following prior consultation with the Visiting Union, the Host Union shall appoint a representative or representatives ("the Liaison Officer(s)") to accompany the Tour Party throughout the Visit for the purpose of carrying out the arrangements made by the Host Union and of looking after the general interests and welfare of the Tour Party. Such appointment shall where possible be made at least 12 weeks prior to the commencement of the International Tour but in any event such appointment will be made and communicated to the Visiting Union no later than eight weeks prior to the commencement of the International Tour. The Liaison Officer must be independent from the executive of the Host Union. The Host Union and the Visiting Union shall consult and attempt to agree the identity and status of the Liaison Officer prior to the Host Union appointing such Liaison Officer.

### **Doctor/Physiotherapist**

- 6.3** The Tour Party must include a Doctor and Physiotherapist. The Host Union will not be responsible for the cost of physiotherapy or massage treatment.

## **Interpreters**

- 6.4** In the event that the Host Union's Liaison Officer(s) is not sufficiently fluent in the language of the Visiting Union, the Manager of the Visiting Union may request, giving at least ten weeks written notice, for the Host Union to provide an interpreter. If such a request is made then the Host Union will meet all internal travel and accommodation expenses of that interpreter from the date of arrival of the Visiting Union until the date of departure.

## **7. Travel, Accommodation, Vehicles and Tour Expenses**

### **7.1 Travel**

- 7.1.1** All arrangements for making reservations and payment (including international airport taxes) of travel for the Tour Party on both the Outward Journey and Homeward Journey including any Deviation shall be the responsibility of the Visiting Union unless otherwise agreed between the Visiting and Host Unions.

- 7.1.2** All other travel (including taxes) and hotel expenses within the territory of the Host Union during the Tour and all other proper and necessary expenditure as determined by the Liaison Officer incidental to the Tour shall, save as otherwise provided in this Agreement, be paid by the Host Union. When a visiting Union participates in Matches during a Tour in more than one country then the respective Host Unions shall share the travel costs and hotel expenses and all other proper and necessary expenditure determined by the respective Liaison Officers incidental to the Tour (save as otherwise provided in this Agreement) on a pro-rata basis.

- 7.1.3** The Visiting Team Manager shall give the Host Union at least seven days notice of the Team's proposed itinerary and transport requirements with confirmed timings and transport requirements for each day to the Liaison Officer the preceding evening.

### **7.2 Hotel Accommodation and Vehicles**

Hotel accommodation and vehicles shall be provided in accordance with the provisions of Schedule 2 of this Agreement. The Host Union acknowledges that in providing accommodation, vehicles and facilitating logistical arrangements that the Visiting Union should not be treated in a materially different way from that of the Host Union such that the preparation by the Visiting Union for Matches is not or cannot be of a substantially similar level to that of the Host Union.

### **7.3 Expenses**

- 7.3.1** Apart from the expenses referred in Clauses 7.1 and 7.2 of this Agreement, all other expenses incurred in respect of personal refreshment during the Tour for any Member of the Tour Party shall be paid by the Visiting Union.

- 7.3.2 Expenses for room service or the serving of meals and beverages outside the agreed table d'hôte full board provision shall (as between the Parties to this Agreement) be paid by the Visiting Union unless authorised by the Liaison Officer as being payable by the Host Union. Any such charges must be settled by the Visiting Union or at its discretion by individual Members of the Tour Party before leaving each hotel and it shall be the Visiting Unions Manager's responsibility to ensure that this is done.
- 7.3.3 Telephonic charges, internet charges, pay-TV charges, fax, or other such charges shall be paid by the individual concerned. Any such charges must be settled by the individual members of the Tour Party before leaving each hotel and it shall be the Manager's responsibility to ensure that this is done.
- 7.3.4 Expenses for taxis or other forms of transport shall only be paid by the Host Union if authorised or provided by the Liaison Officer.

### **8. Baggage**

- 8.1 The Host Union shall pay for charges incurred for the conveyance or transportation of the baggage of the Tour Party in the Host Union.
- 8.2 The Visiting Union will pay for charges incurred for the conveyance or transportation of Excess Baggage. With regard to movement of Excess Baggage between Unions, this may be facilitated by the Host Union but it shall be the responsibility of the Visiting Union to finalise such arrangements and meet the costs thereof.
- 8.3 Throughout the Visit baggage not required may by agreement with the Host Union be left at a central place to be agreed upon between the Host Union and Visiting Union. If reasonably required by the Tour Party during the Visit, such baggage will be conveyed or transported from place to place by the Host Union by such means as it considers most convenient and practical and the costs incurred in respect of such storage and transportation shall be paid by the Host Union.
- 8.4 It is the responsibility of the Visiting Union to arrange and pay for all insurance against loss throughout the Tour of all baggage belonging to the Tour Party.

### **9. Other Expenses**

- 9.1 During the Visit any expenditure which may become chargeable to the Host Union under the terms of this Agreement shall be referred to the Liaison Officer for prior approval.
- 9.2 The Host Union may help facilitate when possible but will not pay for the entertainment or hospitality, however incurred, during the Tour by any member of the Tour Party. Such entertainment or hospitality is the sole responsibility of and will be paid for by the Visiting Union.
- 9.3 The Visiting Union shall be responsible for damage to property caused by any member of the Tour Party.

**10. Matches**

**10.1** All Matches shall be played according to the Laws of the Game and the applicable Regulations.

**11. Match Officials**

**11.1** For International Matches, referees and touch judges shall be appointed as follows:

- (a) A team of three Match Officials from a Union not involved in the Match shall be appointed by World Rugby in accordance with the Regulations.
- (b) In all cases one of the touch judges will be nominated by World Rugby to replace the referee should he be unable to continue and his name shall be made known prior to the commencement of the Tour/Match.
- (c) A fourth and fifth Match Officials shall be appointed by the Host Union.
- (d) A Television Match Official shall be appointed by World Rugby. Such Television Match Official shall be from a neutral country.

**11.2** For all other Matches, referees and touch judges shall be appointed as follows:

- (a) A referee shall be appointed by mutual agreement between the Host Union and the Visiting Union. For the avoidance of doubt any referees selected for such Matches must be on World Rugby Elite Panel of referees unless the Host Union and Visiting Union agree otherwise.
- (b) In the absence of agreement between the parties pursuant to Clause 11.2(a) above within a reasonable time (having regard to the timing of the Tour and other relevant considerations) then the matter(s) will be referred to the World Rugby Executive Committee which shall be entitled to make a decision on the referee appointments for such Matches subject always to such referee being on the World Rugby Elite Panel of referees. The decision of the World Rugby Executive Committee shall be final and binding on notification to the Unions and implemented immediately by the relevant Union(s).
- (c) Touch judges shall be appointed by the Host Union from their International or provincial panel of referees.
- (d) The Host Union shall nominate which touch judge shall replace the referee should he be unable to continue and his name shall be given to the Manager prior to the commencement of each Match.
- (e) The Host Union shall appoint the fourth and fifth Match Officials and the Television Match Officials.

### **12. Illegal and/or Foul Play and Misconduct**

**12.1** The procedures for International Matches set out in Regulations 17, 18 and 20 will apply to the International Matches that form part of the International Tour.

**12.2** For each International Match during the International Tour which are subject to the World Rugby judicial appointment scheme the administrative and appointment policy below will apply. The appointments by the Judicial Panel Chairman shall be made in consultation with the Chairman of the Council.

- (a) The World Rugby Judicial Panel Chairman will appoint an independent Citing Commissioner.
- (b) The World Rugby Judicial Panel Chairman will appoint a Judicial Officer.
- (c) The World Rugby Judicial Panel Chairman will, where required appoint an Appeal Officer or Appeal Committee Chairman as the case may be.
- (d) The Host Union shall appoint a Citing Commissioner Liaison Officer.
- (e) The Host Union shall appoint a Designated Disciplinary Official.

**12.3** Subject to the foregoing, the Host Union is responsible for the administration of the relevant disciplinary personnel and bodies and must ensure that all relevant facilities and equipment are in place and made available to all Citing, Judicial and Appeal Personnel to allow the implementation of the Disciplinary Procedures in Regulations 17, 18 and 20 which shall be applied and respected by both Unions.

**12.4** For non-International Matches during an International Tour the Visiting Union and the Host Union will agree the applicable disciplinary procedures and these shall be stated in Schedule 4 of the Tours Agreement. If agreement is not reached then the procedures that apply to International Matches shall be implemented by the Host Union with the Host Union being responsible for the appointment of disciplinary personnel in accordance with the provisions of Regulations 17, 18 and 20.

#### **The provision of audiovisual materials**

**12.5** Following each International Match it shall be the Host Union's responsibility to ensure that all available broadcast footage shall be made available to both the Host Union and Visiting Union to allow both the Host Union and the Visiting Union to determine whether it would wish to refer any incidents of possible Illegal and/or Foul Play to the Citing Commissioner for consideration. In addition, it shall be the Host Union's responsibility to ensure that any appointed Citing Commissioner has access immediately following the Match to all available angles such limited access time to be agreed in advance of the Match between the Citing Commissioner, Host Union and Host Broadcaster including the

provision of a copy of the footage from any angle requested by the Citing Commissioner. The Host Union must ensure that all relevant protocols and/or contractual arrangements are in place so that it may require the Host Broadcaster and/or other relevant entity to provide the audiovisual coverage promptly following each International Match and no later than two hours following the conclusion of the relevant International Match. The Host Union shall ensure post-Match that both Unions will on request be given expedited access to all available angles of particular incidents that they would wish to review provided that a Union submits its request to the person nominated by the Host Union no later than one hour following the conclusion of the applicable Match or such other period as may be agreed between the parties in consultation with the host broadcaster. The Host Union acknowledges the importance for the integrity of the Game of ensuring that all angles are made available on request and will ensure that arrangements are in place and complied with by the host broadcaster.

### **13. Playing Kit and Team Uniform**

The Visiting Union shall pay and be responsible for:

- 13.1** All its Team members' training/playing kit, which shall be deemed to include tracksuits, jerseys, shorts, stockings, boots, boot studs, laces, scrum caps, mouth guards, protectors, elastic bandages and any other type of "strapping".
- 13.2** Its Team uniform which shall be deemed to include blazers, trousers, sweaters, ties, shoes and scarves.
- 13.3** Replacement of or repairs to uniforms, training/playing kit, including the re-studding of boots.
- 13.4** The laundering of training/playing kit shall be arranged by the Host Union following discussion with the Visiting Union Team Manager or his delegated representative and shall be charged to the Host Union. Training/playing kit includes training/playing jerseys, socks, shorts, wet suits, tracksuits and underwear. Reasonable expenses for the cleaning and ironing of other items of clothing shall be allowed at the discretion of the Liaison Officer. Dry cleaning costs shall be the responsibility of the Visiting Union.

### **14. Training Venue Facilities and Equipment**

- 14.1** The Host Union shall make available to the Visiting Union a suitable training venue, training facilities and equipment in accordance with the provisions set out in Schedule 5 of this Agreement. The costs of providing the training venue, facilities and equipment shall be payable in accordance with the provisions of Schedule 5. Any costs in respect of facilities and/or training equipment required by the Visiting Union over and above the minimum standard set out in Schedule 5 will be a cost to the Visiting Union.
- 14.2** The Host Union acknowledges that in providing training venues, training facilities and equipment for the Visiting Union that the Visiting Union



should not be treated in a materially different way from that of the Host Union such that the preparation by the Visiting Union for Matches is not or cannot be of a substantially similar level to that of the Host Union.

### **15. Familiarisation Visit**

**15.1** The Host Union shall, subject to weather conditions and stadium availability, procure a familiarisation visit for the Visiting Union to the stadium at which any Match on the International Tour is to be played on the day before the applicable Match.

**15.2** Subject to Clause 15.4 below, the familiarisation visit period shall be 1.5 hours in total arrival to departure. The Host Union shall offer the Visiting Union at least two options for the familiarisation visit on the day before the Match. The Host Union shall have first choice of the time period for its own attendance at the stadium that day.

**15.3** During the familiarisation visit, the Host Union or Visiting Union, as the case may be, shall be entitled to continuous access to the following during which the other Team shall not be present in or around the stadium bowl:

- (a) the changing rooms;
- (b) the medical rooms;
- (c) the pitch.

**15.4** Pitch access during the familiarisation visit may be used for a maximum of 1.5 hours. Unions may during this period engage in a full training run in boots provided that there is no scrummaging or repetitive activities which may cause damage to the playing surface. Kicking practice may, subject to prior agreement between the Visiting Union and Host Union, extend beyond the 1.5 hour access period. Any pitch access restrictions imposed by the Host Union's Match manager (or a person with equivalent responsibility) shall apply to both Unions whether such restrictions are attributable to adverse ground or weather conditions or otherwise.

**15.5** In addition to the familiarisation visits referred to above, if the relevant Match is to be played under lights then the Visiting Union and the Host Union shall, subject to weather conditions and stadium availability, be permitted to have a kicking practice under lights if they so desire and this shall be procured at the appropriate time(s) by the Host Union.

**15.6** The Host Union should ensure that other than pitch branding, the pitch reflects Match day conditions during such stadium familiarisation and kicking practice, including but not limited to pitch configuration/sizing, floodlighting where relevant and roofing arrangements (open/closed).

### **16. Medical Arrangements**

#### **Medical Fees and Costs**

**16.1** It is the obligation of the Visiting Union to ensure that the Tour Party is fully insured in respect of injury, disability, illness and repatriation. The

Visiting Union will be responsible for all medical expenses incurred in respect of all medical costs (including but not limited to investigative measures and/or hospitalisation). Details of the Visiting Unions' Medical Insurance Policy are attached as Schedule 3.

- 16.2** The Manager may advise the Host Union of the name of any member of the Team who, as a result of Illness or Injury, may be unfit, in his opinion, to play a useful part in the remainder of the Tour. The member of the Team shall be given a return passage by the first available appropriate means of transport and all proper expenses in connection therewith, as provided herein, shall be paid by the Host Union, provided that the date of departure and means of transport shall be dependent on confirmation by the Visiting Union's Doctor as to the member of the Team's fitness to travel.

### **Medical Supplies**

- 16.3** The cost of Medical supplies which shall include medicine, ointment, liniment, gauze bandage, strappings, lint and other similar items shall be paid for by the Visiting Union.

### **Medical Facilities, Equipment and Personnel**

- 16.4** The Visiting Union is required to identify to the Host Union no later than 8 weeks prior to the commencement of the International Tour their specific medical requirements. The Host Union shall confirm what medical facilities and services will be provided to the Visiting Union no later than 6 weeks prior to the commencement of the International Tour. In any event, where commensurate with local medical practice the minimum requirements set out in Schedule 6 of this Agreement should be provided by the Host Union. The Host Union and Visiting Union may agree to additional medical specialists being available as they may deem appropriate.
- 16.5** The Visiting Union will notify the Host Union of the name of its Tour Party/Team's Doctor no later than 12 weeks in advance of the International Tour.

## **17. Tickets**

- 17.1** The Manager of the Visiting Union will be supplied with complimentary tickets as follows:
- (a) Each International Match: 20 tickets
  - (b) Every other Match: 10 tickets
- 17.2** In addition the Manager shall be supplied with sufficient complimentary tickets for each Match to provide a seat for members of the Tour Party not in the playing squad for a Match (or who do not have a seat in the reserves dugout, coaches box or equivalent location) and two complimentary tickets for each member of the Tour Party subject to the maximum Tour Party size of 46.

- 17.3** Complimentary tickets are to be clearly marked as such by the Host Union.
- 17.4** Complimentary tickets will be for blocks of seats in a prime location so far as this is practicable; but those issued to members of each Team shall be in positions of equivalent quality, readily accessible to the players' dressing room and as close as possible to the reserve bench. Special locations will be allocated for nominated Match replacements with convenient access to the Manager, the Officials and the playing enclosure.
- 17.5** The Host Union shall ensure that the Visiting Union has the option to purchase for each Match in which it is participating an additional two prime location tickets per Tour Party member (as are available at the time of purchase) provided such request is made no later than six weeks prior to the commencement of the International Tour. Should any such request be made thereafter the Host Union shall be under no obligation either to provide tickets or to provide prime location tickets.
- 17.6** The Visiting Union will procure that each Member of the Tour Party complies with the terms upon which the Host Union issues tickets and in particular it is an offence for any Member of the Tour Party to sell or attempt to sell complimentary tickets. It shall also be an offence to sell for profit and/or black market/unofficial commercial activity any purchased tickets. This offence shall be considered to come within the scope of Clause 27 of this Agreement and the Manager shall send home immediately any Member of the Tour Party proved guilty of this offence following a fair and reasonable disciplinary procedure administered by the Visiting Union, such procedure to be administered urgently and as soon as the alleged offence has been notified to the Visiting Union.
- 17.7** The Host Union will provide to the Visiting Union free of charge 50 Match Programmes for each Match forming part of the International Tour.
- 18. Ceremonies and other Match arrangements**
- 18.1** The Visiting Union and Host Union shall agree no later than four weeks prior to the commencement of the International Tour the pre-Match and any relevant post-Match presentation/arrangements that will apply to International Matches forming part of the International Tour. Such arrangements will include the entry to the pitch, the use of any flags on Team entry, the use of any music on Team entry, where Teams (including substitutes and replacements and Team Management) will stand for dignatory presentations and/or anthems and how and by whom the anthems will be played/sung, the timing/location of cultural displays/team challenges and post-Match cup/medal presentations. The Host Union and Visiting Union acknowledge the importance of ensuring that all such processes, anthems and presentations must be conducted strictly in accordance with the agreed timetable and be of the highest quality reflective of the status of international rugby.

- 18.2** Once fixed, such arrangements must be complied with save only when varied and/or added to by written agreement between the Visiting Union and Host Union provided that any such agreement is in place at least seven days prior to the relevant Match.
- 18.3** In the absence of agreement on the issues below then the default position set out below applies:
- (a) On the teams taking the field after any presentations to dignitaries then the anthem of the Visiting Union shall be played. Thereafter the anthem of the Host Union shall be played.
  - (b) Any cultural displays/Team challenges shall take place after the anthems of both Unions.
- 18.4** For any cultural ceremony and/or Team challenge (which for the avoidance of doubt may only be performed by the 22 players selected for the Match), the Team performing the ceremony and/or issuing the challenge must not cross the 10 metre line on its half of the pitch. The Union receiving the challenge shall not cross the 10 metre line on its half of the pitch.
- 18.5** The Host Union and Visiting Union recognise the need to ensure that Teams are granted time and space for warm ups and on-pitch sessions in the build up to a Match and that this must be unimpeded by pre-Match entertainment. As a minimum requirement, the following access shall be provided to both Teams:
- (a) from 60 minutes prior to kick-off and up until 25 minutes prior to kick-off each Team has access to the area between the dead-ball line and the 10-metre line;
  - (b) from 25 minutes until 15 minutes prior to kick-off, the Teams may be restricted by the Host Union Match manager (or equivalent person) to the areas between the 22 and 10-metre line, or between the dead-ball line and the 22; and
  - (c) at 15 minutes prior to the kick-off the Teams may be excluded from the field of play by the Host Union Match manager (or equivalent person).
- 18.6** The Host Union and the Visiting Union recognise the need to provide suitable and broadly equivalent viewing locations, facilities and equipment for coaches and their assistants during each Tour Match. As a minimum requirement the following facilities and equipment must be provided to the Host Union and the Visiting Union:
- (a) A separate coaching cubicle between the 22 metre lines as close to the half way line as is possible. If such a cubicle is not available to both the Visiting Union and the Host Union then premium/best standard seating must be provided between the 22 metre lines and be appropriately blocked off from any public seating.

- (b) There shall be a minimum of four (4) seats available in the cubicle or seats provided pursuant to clause (a) above.
- (c) The cubicle or seating area must have a colour monitor that will display the live feed of the Match and communication lines to allow coaches to install and use analysis equipment.
- (d) The Host Union must provide specific security personnel outside the cubicle or next to the seating area provided and put in place any other security measures that may be necessary for coaches at the Venue.

### **19. Anti-Doping**

- 19.1** The provisions of Regulation 21 shall apply to Doping Control carried out on the players of the Host Union and/or Visiting Union during the Tour. In accordance with Regulation 21.13.4 and subject to Regulation 21.14.7, the responsibility for conducting or arranging Doping Control during the Tour including, but not limited to, Sample collection, result management, the conduct of investigations and disciplinary proceedings and the imposition of sanctions for anti-doping rule violations, including case where there has been no Doping Control carried out may subject to strict compliance with the Anti-Doping Regulations and Guidelines as set out in Regulation 21 be delegated to the Host Union.
- 19.2** The Host Union agrees to comply with the World Rugby's Anti-Doping Regulations and Guidelines and to arrange and implement an expedited procedure for "A" and "B" sample analysis at a WADA accredited laboratory, result management, including an expedited review of positive results by a suitably qualified and experienced review board, disciplinary proceedings where required and the imposition of sanctions where an anti-doping rule violation is found to have been committed.
- 19.3** The Host Union shall arrange, as far as reasonably practical, for all "A" sample analysis results in respect of samples collected during the Tour to be confidentially received by the Host Union (with a copy to the World Rugby Anti-Doping Manager) from the WADA accredited laboratory and reviewed by a review board. Such receipt and review should take place prior to the next Match on Tour of the player that provided the sample in question in order to ensure that, subject to the provisions of Regulation 21.19, a player that may have committed an anti-doping rule violation is provisionally suspended and does not participate in any further Matches on Tour or otherwise pending the outcome of his case.
- 19.4** The Host Union and the Visiting Union also agree that any other anti-doping rule violation that may be committed whilst on Tour which does not arise out of the provision of a sample by a player shall also be dealt with expeditiously and in accordance with the provisions set out in Regulation 21.
- 19.5** The Host Union and the Visiting Union also agree that each player in their Tour Team will consent and agree in writing to the following terms:

- (a) to comply with and be bound by all of the provisions of Regulation 21 from time to time in force (including the prevailing WADA Prohibited List) and all WADA International Standards incorporated into the World Rugby's Anti-Doping Regulations;
- (b) acknowledges and agrees that World Rugby has the right to attend any hearing as an observer and has jurisdiction to refer any decision made at first instance to a post hearing review body.
- (c) acknowledges and agrees that the Host Union, Visiting Union and/or World Rugby has jurisdiction to impose sanctions as provided for in Regulation 21 and that any dispute arising out of a decision made pursuant to Regulation 21, after exhaustion of the process expressly provided for therein, may be appealed exclusively as provided in Regulation 21.27 to an appellate body for final and binding arbitration, which is the Court of Arbitration for Sport (CAS) and that World Rugby shall have the right to participate in any such proceedings;
- (d) acknowledges and agrees that the governing law of the appeal heard by CAS shall be English law and that the decisions of the CAS shall be final and enforceable;
- (e) agrees that they will submit a Therapeutic Use Exemption form if required to do so in accordance with Regulation 21; and
- (f) agrees that their personal anti-doping data relating to the Doping Control process (including test distribution planning, sample collection and handling, laboratory analysis, result management, hearings and appeals) can be processed (for example transmitted, disclosed, used and stored) by and amongst World Rugby, Host Union and other Member Unions, the World Anti Doping Agency (WADA), National Anti Doping Agencies and/or other Anti Doping Organisations (as applicable) in electronic form including but not limited to as part of the ADAMS database system;
- (g) agrees that they have read and understood the "Athlete's Information Notice – Doping Control-Related Data" which is set out in Schedule 5 of the World Rugby Anti-Doping Regulations.

## **20. Commercial Rules**

**20.1** The provisions of Regulation 11 apply to all Matches forming part of the International Tour.

**20.2** All relevant information regarding sponsorship or other financial assistance should be exchanged between the Unions concerned in an International Match not later than 12 weeks prior to the date of the said International Match so as to avoid conflict between sponsorship agreements entered into by the respective Unions. In the event that Unions have not resolved such conflict by mutual agreement 21 days prior to the International Match taking place, the matter shall be referred by either Union to the CEO, or his designee, who shall, as soon as

reasonably practicable, adjudicate on the matter pursuant to the provisions of Clause 25 of this Agreement. The decision of the CEO, or his designee, shall be final and binding on the Unions concerned.

- 20.3** The luggage truck, van(s) and coach(es) provided by the Host Union to the Visiting Union pursuant to Schedule 2, Clause 2 shall be unbranded save for the standard mark of the hire company and the vehicle manufacturer. Prior to arranging vehicles pursuant to this Clause 20.3, the Host Union shall consult with the Visiting Union and where it is possible for the reasonable requests of the Visiting Union to be met in relation to branding and/or sponsorship livery on such vehicles and/or their specification without any additional cost to the Host Union then the Host Union shall provide vehicles in accordance with such requests of the Visiting Union.
- 20.4** Training Venues provided for the Visiting Union by the Host Union may during the use by the Visiting Union of the Training Venue be branded by the Visiting Union's commercial partners subject to any local law requirements and/or existing training venue contractual commercial arrangements and/or advertising standards regulations governing the Training Venue and/or restrictions applying in educational establishments. Any and all costs associated with such branding shall be at the sole cost of the Visiting Union and for the avoidance of doubt the Host Union shall be under no obligation to provide Training Venues clean of existing advertising and/or branding.
- 20.5** At any Press Conferences staged by the Visiting Union outside of the Match Venue the commercial partners of the Visiting Union referred to in Clause 20.4 above shall have the exclusive right to branding and any signage at and within the Press Conference venue. Any and all costs associated with such branding and signage shall be the sole responsibility of the Visiting Union.
- 21. Security**
- 21.1** Appropriate security shall be provided by the Host Union in accordance with the applicable security risk and/or threat prevalent at the time and/or at any time during the Tour, such security to include and cover each Match Venue, Training Venue and other relevant locations, including but not limited to Team hotels. The Host Union shall ensure that all such appropriate and necessary security precautions are in place for the Tour.
- 21.2** If considered necessary by the Visiting Union, a security plan shall be discussed by the Host Union and Visiting Union and agreed at least four weeks prior to the commencement of the International Tour. Such security plan shall include the provision a safe environment for the Visiting Union at all relevant times during the Tour. Police escorts shall be provided to the Visiting Union where available when the Team of the Visiting Union is travelling to a Match forming part of the International Tour.
- 21.3** The costs of all Tour security arrangements and implementation thereof in accordance with the advice of the appropriate authorities relevant to the

applicable security risk and/or threat prevalent at the time shall be the responsibility of and paid by the Host Union. In the event that the Visiting Union wishes additional specialist security provision beyond this level, the Visiting Union shall arrange such provision and meet the costs thereof.

**21.4** In the event of a dispute between the Host Union and Visiting Union in relation to any security matter and the Host Union and Visiting Union are unable within a reasonable time (always having regard to the timing of the Tour) then such dispute should be referred by the parties to an agreed and suitably qualified independent expert in security matters (having regard to the nature of the dispute/territory) for binding resolution.

## **22. Media Rules**

**22.1** As a general principle, the organisation and management of media facilities and any associated media relations programme for the International Tour that facilitates the interface between the Teams and the media is the responsibility of the Host Union.

**22.2** Both the Visiting and Host Union acknowledge the importance of communicating and cooperating with the media in order to enhance the image of the Game. The Host Union and Visiting Union further recognise the need for cooperation taking into account the reciprocal nature of Tours and the requirement to promote the Game in the country of the Host Union.

**22.3** For the purposes of this Agreement, media activities shall be deemed to include access to Teams on non-Match days and Match days and include broadcast operations.

**22.4** The operative provisions of this Clause 22 of this Agreement shall commence seven days prior to the first Match of the Tour. If a Team arrives less than seven days prior to the first Match then they will apply with immediate effect on arrival.

**22.5** If a Visiting Union is in the territory of the Host Union more than seven days prior to the first Match then the scope of the media activities for these extra days shall be at the discretion of the Visiting Union.

### **Pre-Tour Requirements**

**22.6** The Visiting Union and Host Union shall agree no later than two weeks prior to the commencement of an International Tour the applicable media schedule to be implemented during the Tour including media activities and broadcast requirements ("Media Schedule"). The Media Schedule will incorporate the minimum requirements as set out in this Clause 22. The Media Schedule will be provided to relevant media organisations.

**22.7** At least two weeks prior to the commencement of the Tour or immediately on the public announcement of the Tour Party (whichever is later) the Visiting Union must make available head and shoulder photographs and biographies of all Players in the Tour Party to the Host Union for use in Match programmes. Such photographs and biographies must be provided



as soon as possible after the announcement of the Tour Party and prior to the commencement of the Outward Journey of the Tour Party.

**22.8** Any changes to the Media Schedule and/or Tour Party should be notified by the relevant Union to the media as soon as practicable.

**22.9** If a dispute arises between the Host Union and Visiting Union over the scope and terms of the Media Schedule prior to the International Tour and the Host Union and Visiting Union are unable, within a reasonable time, to resolve the dispute then either Union may refer the matter to the CEO, or his designee for adjudication in accordance with Clause 25 of the Agreement.

### **Broadcast Requirements**

**22.10** As a general principle, the Host Union's domestic broadcast contract and/or arrangements cannot commit a Visiting Union to broadcast activities without such Visiting Union having given its prior written consent. In assessing whether such consent should be granted however, Visiting Unions shall have regard to the reciprocal nature of International Tours, the fact that broadcast and public relations expectations do differ from Union to Union and the importance of cooperating with the media in order to enhance the image and promotion of the Game. For the avoidance of doubt, this means that no camera sweeps or fixed cameras of any TV broadcaster or news media organisation will be allowed in the dressing room, Team hotel or on Team transport of the Visiting Union unless agreement has been reached prior to the commencement of the Tour. Accordingly, no media and/or broadcast activities for any International Tour which impact on a Visiting Union should be entered into by a Host Union with any media organisation unless and until agreements on such commitments in respect of the Visiting Union have been approved by the Visiting Union.

### **Team Arrival and Squad Announcement**

**22.11** The Visiting Union shall hold an "On Arrival" media conference within 24 hours of arrival in the territory of the Host Union.

The Host Union and Visiting Union should announce their Match day squad of 23 players by position/number no later than 48 hours prior to the agreed Match (unless specifically agreed otherwise between the two Unions).

### **Non-Match days**

**22.12** On non-Match days the following minimum requirements must be met by both the Visiting Union and Host Union:

- (a) There will be one optional non-media day per week if the relevant Union so elects, provided always that any such non-media day may not be taken on the day of a Match or the day prior to the Match. (The position for weeks with mid-week matches is set out in Clause 22.13).

- (b) Training sessions of the Host Union and Visiting Union shall be either fully open to the media or open to the media for a limited period. The limited session must be accessible to media for a minimum of 15 minutes. This access window can be at the start or the end of the training session as determined by the relevant Union. If a Union has more than one training session in a single day then it only has to grant access to one of these sessions in accordance with the foregoing. A Union may open any training session to the public at its own discretion.
- (c) The 15 minute window referred to in Clause 22.12(b) above is primarily designed to facilitate non-interview TV and photographic opportunities. Therefore the Host Union and Visiting Union must in addition undertake an interview/briefing session on non-Match days for written press save for the non-media day referred to in Clause 22.12(a) above. The non-Match day written press interview/briefing session shall be held at a location and time determined by the relevant Union subject to both the Visiting Union and Host Union using their best endeavours to ensure that Team announcements prior to a Match do not occur simultaneously.
- (d) The Host Union and Visiting Union shall rotate Players made available to the media throughout match week and during a Tour period. The team media manager will liaise with the media to determine which of the Players will be made available to media in the week of a Match to provide relevant and topical access. All Players in a Match or Touring Party shall be deemed available by request. Team media managers should also take into account the requirements of media deadlines and avoid media opportunities that are late in the day.
- (e) The minimum requirements set out in the Clause 22.12 above must be taken into account when allocating Players for the following activities:
  - (i) Training Day/Non-training Day: three Players and one coaching representative to be in attendance;
  - (ii) Team Announcement; head coach, one assistant coach, captain to be in attendance. Save that the captain shall not need to be in attendance if he has a stand alone media day. In addition, up to five Players (selected for the Match) shall be made available immediately following the Team announcement if requested by the media.
  - (iii) Captain's run (or day before Match if there is no training): the head coach and captain or captain and vice-captain shall be made available to the media at a time and venue determined by the Team.
  - (iv) Recovery day: one assistant coach must be available.

**22.13** If during the seven day cycle between International Matches a “mid-week” Match is played by the Visiting Union, then the team media manager of the Visiting Union will liaise with the media to determine which Players and coaching staff will be made available from the selected mid-week Team. Those Players and coaching staff involved in the previous Match may be allowed a non-media day in this period between matches provided there is a suitable number of personnel available to fulfil the minimum requirements as stipulated above.

**22.14** To assist the promotion of the Tour and Matches in the Host Union territory both Unions agree to undertake promotional activities that include a window of access for media. This may include organised photo opportunities, coaching clinics, autograph signings, hospital visits. Such activities should be the subject of consultation prior to the commencement of the Tour and agreement reached on logistical arrangements at least 24 hours prior to the relevant promotional activity.

### **Match day**

**22.15** The Host Union and Visiting Union shall comply with the following minimum Match day requirements:

- (a) Pre-Match interviews: on arrival at the Match Venue each Team must provide, if requested 24 hours prior to the Match kick-off, a minimum of one senior Team representative (for example, the head coach) for a brief pre-Match interview with the TV and radio host broadcaster. If included in the Media Schedule then interviews shall also be given to the rights holding broadcaster of the Visiting Union.
- (b) Half-time interviews: if pre-approved by the Visiting Union or Host Union (as the case may be) 24 hours prior to the commencement of the relevant Match, half-time interviews may be undertaken. For the avoidance of doubt, however the decision on whether to provide a member of the Visiting Union is solely at the discretion of the Visiting Union and not the broadcaster.
- (c) Post Match TV Flash Interviews: the Visiting Union and Host Union shall provide a minimum of two Team representatives (preferably the captain and head coach) to be available to the host broadcaster within pre-agreed timeframes, either on field or off field. The “Man-of-the-Match” shall also be made available by the relevant Union to undertake post-Match TV flash interviews. Further post-Match interviews and the number of Players to be made available must be agreed with the host broadcaster and the relevant Union 24 hours prior to Match. Where necessary, translation services should be provided by the Host Union or broadcaster for Visiting Union interviews.
- (d) Media conference: the Host Union and Visiting Union shall each hold a media conference the first of which shall start no later than 30 minutes after the final whistle. The minimum requirement for such media conferences is attendance by the playing captain and head

coach. The running order for such media conferences will be pre-agreed between the Visiting Union and Host Union and should take into account any media deadlines that apply to either the domestic or visiting media. Where relevant, the Host Union shall arrange suitable translation services for the visiting media.

- (e) **Mixed Zone:** a suitable area should be made available for written press to access players post-match after the media conferences. The mixed zone should be managed by the respective team media managers who should seek requests for players from the media, and make available a minimum of 6 players from their respective team, plus one coaching representative. Written press have priority in the media zone.

### **On Tour disputes**

- 22.16** If a dispute arises between the Host Union and Visiting Union over the implementation of this Clause 22 and the Host Union and Visiting Union are unable within a reasonable time (always having regard to the length of the Tour) then either Union may refer the matter to the CEO, or his designee, for adjudication in agreement with Clause 25 of the Agreement.

### **23. Delayed, Postponed, Abandoned and Cancelled Matches**

- 23.1** Subject always to the provisions of Law 1.6, after full consultation with the Visiting Union, the Host Union shall have the sole right and discretion to determine whether or not an International Match shall be postponed on account of adverse weather conditions or the state of the ground.
- 23.2** Travelling and hotel expenses incurred by the Visiting Union in connection with any such futile visit shall be paid by the Host Union.
- 23.3** The commencement of Matches at the scheduled start time shall be the first priority in all instances. However there may be circumstances in which Matches need to be delayed, postponed, abandoned or cancelled.

#### **Delayed Matches**

- 23.4** Subject to the provisions of Clauses 23.1 and 23.2 where a Match cannot be started at the scheduled time, it will be considered delayed. Decisions on the period of delay of Matches will be taken as early as possible on the Match day and via agreement between the Host Union and the Visiting Union. After full consultation with the Visiting Union, the Host Union shall have the sole right and discretion to determine the time of the delayed kick-off.

#### **Abandoned Matches**

- 23.5** Where a Match is stopped by the Referee following commencement and cannot be completed the same day, it will be rescheduled at the earliest possible time subject to agreement between the Visiting Union and the Host Union. There shall be full consultation between the Host Union and the Visiting Union during which both the parties shall seek to agree a date

for the rescheduling of the Match, but in the absence of such agreement, the Host Union shall have the sole right and discretion to determine when the abandoned Match shall be rescheduled. The Visiting Union shall use its best endeavours to play the abandoned Match at the designated rescheduled time as determined by the Host Union [provided the rescheduled Match is on a date within the existing Tour time frame and not scheduled on the day prior or after another Tour Match].

### **Postponed and cancelled Matches**

**23.6** Subject to the provisions of Clauses 23.1 and 23.2 where a Match cannot be commenced on the day on which it is scheduled, it shall subject to agreement between the Visiting Union and the Host Union be rescheduled at the earliest possible time.

**23.7** If a dispute arises between the Host Union and Visiting Union over the rescheduling of delayed, abandoned and/or postponed and/or cancelled Matches if the Host Union and Visiting Union are unable in a reasonable time to reach mutual agreement on the rescheduling of Matches pursuant to Clause 23.6 above then either Union may refer the matter to the CEO or his designee for adjudication. The CEO or his designee may at his discretion deal with the matter pursuant the Clause 25.3(a) of this Agreement or refer the matter to the Judicial Panel Chairman for adjudication by a Judicial Officer or Disciplinary Committee.

**23.8** Subject to the provisions of Clauses 23.1 and 23.2 where the delay, abandonment, postponement or cancellation of a Match is deemed to be caused by either the Visiting Union or the Host Union, not acting under the instruction of a Match Official then the matter shall be dealt with in accordance with Clause 25 of this Agreement.

### **24. Force Majeure**

**24.1** If and to the extent that either Party is prevented or delayed by an Event of Force Majeure from performing any or all of its obligations under this Agreement it shall promptly notify the other Party in writing, specifying the nature, cause and consequences or likely consequences of the Event of Force Majeure together with such evidence verifying the Event of Force Majeure as it can reasonably give and the period for which it estimates that the Event of Force Majeure will continue.

**24.2** In the event that either Party is prevented from complying with any or all of its obligations under this Agreement by an Event of Force Majeure the non-performance or failure of the relevant Party's obligations shall not be deemed to be a breach of this Agreement save where the Party or Parties is/are prevented from complying with its or their obligations by the Force Majeure event has/have failed to use its/their best endeavours to comply with its/their obligations and/or minimise the impact of the Force Majeure event in which circumstances the relevant Party or Parties (as the case may be) shall be deemed to be in breach of this Agreement. In the event that this Agreement cannot be substantially performed or its obligations substantially fulfilled for a continuous period of two months then the

defaulting Party or either Party (if both are affected) may terminate this Agreement by notice in writing at the end of that period.

- 24.3** In the event that a Team fails or refuses to play a Match in accordance with the Tour Schedule or abandons a Match before completion and claims that its failure, refusal or abandonment is due to an Event of Force Majeure, the matter shall be dealt with in accordance with the provisions of Clause 25 of this Agreement. If in the opinion of the Disputes Committee, the reason for such failure, refusal or abandonment does not amount to an Event of Force Majeure, the Disputes Committee shall be entitled to take such action as it deems fit in terms of Clause 25 including, but not limited to imposing a fine and/or requirement to pay compensation on the relevant Union and/or rescheduling the Match.

**25. Dispute Resolution and Compliance**

- 25.1** Disciplinary issues arising out of Illegal and/or Foul Play and/or Misconduct shall be dealt with in accordance Clause 12 of this Agreement.
- 25.2** Matters relating to Anti-Doping shall be dealt with in accordance with Clause 19 of this Agreement.
- 25.3** All other disputes, issues and alleged breaches of this Agreement shall be dealt with in accordance with the provisions below.
- (a) When a matter is referred to the CEO as specifically provided for in this Agreement (and/or pursuant to Regulation 15), and/or where both parties agree that the matter be referred to the CEO for resolution and when the CEO is prepared to accept such referral the CEO (or his designee) shall on receipt of notification of the dispute, issue and/or alleged breach determine the procedures that he wishes to adopt to resolve the matter. The CEO (or his designee) shall have full discretion in relation to such procedures and what evidence and/or information he requires. The CEO may if he considers it appropriate refer the matter to the Judicial Panel Chairman and in such circumstances the matter will be dealt with pursuant to Clause 25.3(b) below. In any matter dealt with by the CEO or his designee, each Union shall be given the opportunity to set out its position and each Union shall provide such assistance and information and/or documentation as the CEO (or his designee) may require. The CEO (or his designee) shall make a decision as soon as reasonably practicable. Such decision shall be final and binding on notification to the Unions and implemented immediately by the relevant Union(s).
- (b) All other disputes and/or alleged breaches of the Agreement shall be referred to the Disputes Committee via the Judicial Panel Chairman which shall deal with the matter in accordance with Schedule 7 of this Agreement.

### **26. Limitation on Liability of the Host Union**

**26.1** The Host Union shall be under no liability for the death of any member of the Tour Party whilst on the Visit save where any such death is caused by the negligence of the Host Union. Save insofar as the Host Union is expressly made liable in this Agreement, the Host Union shall be under no liability for any loss, damage, injury, detention or delay, or irregularity of any sort, which may be occasioned or happen to any member of the Tour Party or to his/her baggage or property, or for any consequence of lockouts, strikes or labour difficulties, acts of terrorism or for any act or default on the part of the Host Union, or its servants or agents or the servants or agents of any company, firm or person save where any personal injury is caused by the negligence of the Host Union. No insurance of any description will be provided by the Host Union for the benefit of any member of the Tour Party. Such Insurance shall be the responsibility of the Visiting Union.

### **27. Discipline**

**27.1** The Manager shall have power to send home any member of the Tour Party whose conduct may, in his absolute opinion, have rendered such member unsuitable to continue as a member of the Tour Party. The cost of sending a replacement of such member returned home shall be the expense of the Visiting Union. A full report of the circumstances under which a member has been sent home shall be submitted by the Manager to the Visiting Union and subject to the provisions of Regulation 17.23 (Misconduct) the Visiting Union will be responsible for taking such disciplinary action as it determines to be appropriate. The name of the member sent home and the date of his departure shall be reported to the Host Union.

### **28. General provisions**

**28.1** Subject to the provisions of this agreement, including but not limited to Clause 25, either party hereto may terminate this Agreement forthwith by written notice to the other if:

- (a) the other commits a material breach of its obligations hereunder and shall not have remedied the same (if capable of remedying) (i) within seven days of being given notice in writing by the other party specifying the breach and requiring its remedy where such notice is given up to one week prior to the commencement of the Tour, (ii) within 72 hours where such notice is given within one week prior to the commencement of the Tour and (iii) within such period as reasonably specified by the party not in breach where such notice has to be given during the course of the Tour. In assessing the materiality of any breach particular regard will be had to those breaches which could have a significant impact on the operation of the Tour and the preparation or performance of the Host Union and/or Visiting Union as the case may be and/or those which may have a significant impact on the commercial values accruing to the Host Union from the International Tour; or

- (b) the other enters into liquidation whether compulsory or voluntary or enters into any arrangement or composition for the benefit of its creditors or has a receiver (whether administrative, Law of Property Act 1925 or otherwise) appointed or an administration order made in respect of it.

**28.2** Termination of this Agreement by either Party and for any reason shall be without prejudice to any rights or obligations existing or that may have accrued as at the date of such termination or which may accrue subsequent thereto to either party and in addition shall be without prejudice to any action taken (or to be taken) by the relevant disciplinary person and/or entity whether pursuant to the provisions of this Agreement and/or the World Rugby Regulations or otherwise.

**Governing law**

**28.3** This Agreement shall be construed under English law and shall be subject to the exclusive jurisdiction of the English courts to which both parties hereby irrevocably submit.

**Relationship**

**28.4** Nothing in this Agreement shall constitute or be construed as constituting a partnership or joint venture between the parties or shall authorise any party to enter into contractual relationships or incur obligations on behalf of the other party.

**Non-assignment**

**28.5** This Agreement is personal to the parties and the benefit thereof may not be transferred assigned or devolved without the other party's prior written consent.

**Third party rights**

**28.6** A person who is not a third party to this Agreement has no right under the Contracts (Rights of Third Parties) at 1999 to rely upon or enforce any term of this Agreement but this does not affect any right or remedy of a third party which exists or is available apart from that Act.

**28.7 Notices**

- (a) any notice to be given by either party to this Agreement shall be in writing and shall be deemed duly served if delivered personally or sent by e-mail, telex, facsimile transmission or by first class ordinary post (airmail in the case of an address for service overseas) to the addressee at its address stated in this Agreement;
- (b) any notice sent by facsimile shall be deemed served when dispatched and any notice served by post shall be deemed served 5 working days after the date of posting;
- (c) in proving the service of any notice it will be sufficient to prove in the case of a letter that such letter was properly stamped, addressed



and placed in the post or delivered or left at the address of the addressee stated in this Agreement if delivered personally and in the case of a facsimile or other means of electronic communication (including e-mail) that such transmission was duly dispatched and an appropriate answer back or transmission activity report received by the sender.

### **28.8 Confidentiality**

- (a) The parties hereto agree to keep and procure that its directors, employees and agents shall keep the terms of this Agreement strictly confidential at all times.
- (b) The obligations of confidentiality set out in clause (a) above will not apply to any disclosure of such information which is required and/or necessary in connection with the implementation of this Agreement provided always that the party disclosing such information notifies such third party of the restrictions contained in clause (a) and shall use its reasonable endeavours to procure that such party complies with the terms of clause (a).
- (c) The parties hereto further agree not to make any announcement or communication regarding this Agreement except on a jointly approved basis.

### **Waiver**

- 28.9** Failure of either party hereto at any time to demand strict performance by the other of any of the undertakings, terms or conditions set forth herein shall not be construed as a continuing waiver or relinquishment thereof and each party may at any time demand strict and complete performance by the other of the said undertakings, terms and conditions.

### **Invalidity**

- 28.10** In the event that any provision of this Agreement shall be deemed to be illegal, void, invalid or unenforceable under the laws of any jurisdiction, the legality, the validity and enforceability of the remainder of this Agreement in that jurisdiction shall not be affected and the parties hereto agree to replace such illegal, void, invalid or unenforceable clause with a mutually agreed legal, valid and enforceable replacement clause, as close as possible in interpretation to the illegal, void, invalid or unenforceable clause and that the legality, validity and enforceability of the whole of this Agreement shall not be affected in any other jurisdiction.

### **Entire Agreement**

- 28.11** This Agreement contains the entire understanding of the parties with respect to the subject matter of this Agreement and supersedes all prior agreements between the parties. No variation of the terms hereof may take place save by way of a written document duly signed on behalf of both parties.

**29. Acceptance**

**29.1** The Tour is undertaken and will be conducted in accordance with the Bye-Laws, Regulations and the Laws of the Game, which apply at the time of the commencement of the Tour and the provisions of this Agreement, all of which shall be binding on the Tour Party.

**29.2** Acceptance by the Visiting Union of this Agreement shall be deemed to be an acceptance thereof by each member of the Tour Party, who shall be made fully aware of the terms of this Agreement before the commencement of the Tour and given a copy and shall acknowledge receipt of the same.

**29.3** Save insofar as the Host Union is expressly made liable in this Agreement and/or in respect of any personal injury caused by the negligence of the Host Union, the Visiting Union will save harmless and keep indemnified the Host Union and its servants and agents from all actions, proceedings, costs, claims and demands on the part of the members of the Tour Party or any of them.

Signed at [\* ] on [ Date ]

For and on behalf of the Host Union: .....

For and on behalf of the Visiting Union: .....

**RUGBY UNION TOUR TO**

It shall be a condition of participation in the above Tour that all members of the Tour Party will require, prior to departure, and, in any event, not later than [ Date ] to confirm, in writing, that they acknowledge receipt of a copy of this Agreement and agree to abide by its terms.

This is a Tour Agreement and not a Contract of employment.

Signed: .....

Secretary: .....

Date: .....

Union: .....

I acknowledge receipt of this Agreement and agree to abide by its terms.

Signed: .....

Member of Tour Party: .....

Date: .....

Name of member of Tour Party: .....

*(IN BLOCK CAPITALS)*

---

**SCHEDULE 1. LIST OF MATCHES**

Match 1 [XXX] v [XXX] at [VENUE AND CITY] K.O.

Match 2 [XXX] v [XXX] at [VENUE AND CITY] K.O.

Match 3 [XXX] v [XXX] at [VENUE AND CITY] K.O.

## SCHEDULE 2. ACCOMMODATION AND VEHICLE PROVISION

### 1. Accommodation

1.1 Hotel accommodation for the Visiting Union, preferably with a swimming pool, shall be provided by the Host Union to at least a 4-star standard. The Host Union should offer the Visiting Union a minimum of two hotel choices of this standard and the Visiting Union shall be entitled to select its preferred hotel from the choices provided. Hotel options shall be communicated by the Host Union to the Visiting Union within one month of Match Venue confirmation. Subject to agreement between the Visiting Union and the Host Union, a Tour Party may be based in a location other than in the Match city during the build up to an International Match.

1.2 All hotels provided for the Visiting Union by the Host Union will include the facilities, equipment and services set out in clauses (a) to (i) below. The Host Union will be responsible for arranging the provision of such facilities, equipment and services and will meet all costs in respect thereof:

- (a) a suite for the Manager or for the Coach with an option to upgrade to a second suite at the Visiting Union's cost;
- (b) a single room for other members of the Tour Management and the captain of the Team up to a maximum of 18 single occupancy rooms. Where possible single rooms should have double beds for Management and Team Captain at all times; and
- (c) twin rooms for all other members of the Tour Party and where possible twin rooms should have double beds for all Players at all times. If twin rooms do not have two double beds, the Host Union should provide rooms containing a double bed for at least 60% (sixty percent) of the Players in the Tour Party;
- (d) a team/meeting room capable of seating the entire Tour Party and equipped with a projection screen, TV, DVD and video, where possible at least 4 internet points and access to broadband and/or wireless internet, whiteboard, LCD screen and flip chart;
- (e) a recreational room which shall where possible be a separate room which shall contain such recreational equipment as agreed between the Visiting and Host Unions. This room must be of sufficient size to allow physios to work with Players. If requested by the Visiting Union, the Host Union shall arrange for the provision of assorted snacks in the recreational room and the provision of isotonic drinks either refrigerated in liquid form or in powdered form all at the Visiting Union's cost but with the Host Union seeking to source such provisions at the best available cost. The Host Union shall also arrange for and meet the cost of the provision of at least 3 litres of refrigerated water per person per day subject to any other arrangement agreed between the parties.

- (f) a separate medical room of an appropriate size for the medical team of the Visiting Union to work within on the Players' floor of the hotel;
- (g) a suitable space for press conferences which shall be separate from the team and recreation room;
- (h) a lockable baggage/storage room of an appropriate size located on the ground floor where reasonably practicable;
- (i) a private meal room or separate area in the dining area for meals taken by the Tour Party.

The rooms to be provided pursuant to Clauses (d), (e), (f) and (h) shall be provided for the exclusive use of the Tour Party on a 24/7 basis for the duration of the Tour Party stay in the hotel.

- 1.3** Hotel expenses shall be understood to be restricted to those for bed, table d'hôte breakfast, luncheon and dinner or the equivalent on Match day subject to any post-Match meal provision by the Host Union elsewhere. Each lunch menu provided should comprise of at least two starters and two hot meal choices plus sandwiches. Each dinner menu provided should comprise of at least two/three starter choices, two/three hot main courses and two dessert choices. The menus will be agreed between the Host and Visiting Unions. In addition, with the agreement of the Liaison Officer the following may also be provided if required: soft drinks, fruit juices, milk with luncheon and dinner. Outside the provision with meals, all other beverages will be paid for by the Visiting Union. Visiting Unions must submit any specific dietary requirements for the Visiting Union and/or Members of the Tour Party to the Host Union two weeks in advance of the commencement of the Tour. The Host Union shall ensure that subject to budget best endeavours are made to meet any such specific dietary requirements. In the event that the Visiting Union Tour Party wishes to take occasional meals out of the hotel on allowance, the Host Union, subject to receiving at least seven days notice together with a written invoice, shall endeavour to make available the equivalent cash allowance but shall be under no obligation to do so.

## **2. The Provision of Vehicles**

- 2.1** The Host Union shall make available to the Visiting Union a luggage truck or van of at least 10m<sup>3</sup> for airport/hotel transfers plus to be available 24 hours per day a van/people carrier (minimum 7-seater) and a coach which shall be at least a 50-seater. Team Management shall only be permitted to drive the van/people carrier with advance Host Union approval and subject to the advance provision of a clean driving licence and any other conditions specified by the Host Union's insurers. If the Visiting Union does not have an approved driver or does not wish to drive then the Host Union will provide a driver. The Host Union shall meet any and all costs associated with the provision of the luggage truck, van and coach including drivers and insurance and fuel costs/other vehicle expenses. The vehicles provided must all be of an appropriate standard.

**SCHEDULE 3.**      DETAILS OF VISITING UNIONS'  
MEDICAL INSURANCE POLICY

---

**SCHEDULE 4.** DISCIPLINARY PROCEDURES FOR  
NON-INTERNATIONAL MATCHES

## SCHEDULE 5. TRAINING, FACILITY AND EQUIPMENT REQUIREMENTS

The Host Union shall provide and make available dedicated training facilities for the use by the Visiting Union. Such dedicated training facilities shall be of a high standard and shall include and meet the following requirements:

1. The training facilities shall be as close as possible to the Visiting Union's hotel and no more than 30 minutes transfer by coach in the absence of traffic conditions that could not reasonably have been foreseen by the Host Union.
2. The training facilities should include one full-sized fully marked rugby pitch (with posts) of similar size to the Match pitch and where possible access to a reserve pitch which where reasonably practicable should have posts. For the avoidance of doubt, where the Host Union Team has a reserve pitch at its training facility the Visiting Union must also have one.
3. The training facilities should be available both a.m. and p.m. for the exclusive use of the Visiting Union at the time it requires access. An outline training plan should be provided by the Visiting Union to the Host Union at least four weeks in advance with updates provided as and when known and final confirmation of such times to be advised not less than 24 hours in advance by the Manager to the Liaison Officer. Exclusive use will be provided at designated times.
4. The training facilities will be secure as far as is practicable. It will be possible to control media and public access to the pitch and enforce closed session restrictions. The pitches will be grass rugby pitches to the best available standard.
5. Adequate and uniform lighting will be provided for late training sessions at the training facilities. There will be adequate changing rooms space and showers. As far as practicable, a tribune for media and staff and a storage room for training kit will be available at the training facility.
6. Unless the Visiting Union is making its own arrangements, the following equipment shall be provided for the Visiting Union for use at the training facility.
  - 20 agility poles
  - up to 15 tackle suits
  - 15 hit shields
  - 6 tackle bags
  - 50 marker cones
  - 1 sled scrum machine
  - 1 hand pump and gauge
  - 2 ice baths (if requested by the Visiting Union)
  - 12 match specification balls for training



7. The Host Union will make available a weights training gymnasium. The gymnasium shall be as close as possible to the Visiting Union's hotel and no more than 30 minutes transfer by coach.
8. The following is the type of equipment which must be provided to the Visiting Union at the gymnasium:
  - 2 lifting platforms
  - 2 olympic bars with olympic plates or rubber coated plates (1.4 tonnes)
  - A stretching area
  - A chin bar
  - 2 flat benches
  - A glute-ham raise
  - A leg extension
  - A leg press
  - A squat support, an incline bench, a flat bench press (each with appropriate weights) – these three items may be replaced by a row bench press or a butterfly or a cable pull/push
  - A set of dumbbells up to 50kgs
  - 2 stationary bikes
  - 2 treadmills
  - 2 rowers
9. Visiting Unions may bring additional equipment should they wish, however the cost of hiring and transporting such additional equipment shall be borne by the Visiting Union.
10. The Visiting Union shall be entitled to have access to a swimming pool of an appropriate size and standard for its exclusive use at designated times, such facility to be located no more than 30 minutes from the Visiting Union's hotel. Such access must still be arranged with the Host Union if any pool at the Team hotel is inadequate for the Team's purposes. The Visiting Union will notify the Host Union at the earliest opportunity whether the pool at the Team hotel is suitable for its purposes or not and if it is not the Host Union will be responsible for making alternative arrangements.
11. In the event of severe weather or unplayable training conditions, the Host Union shall use all reasonable endeavours to provide a suitable indoor training area. The Host Union will endeavour to make available to the Visiting Union the following indoor facility (at least 600m<sup>2</sup>). The indoor facility will be:
  - Minimum size of a basketball court to allow backline move practice
  - High enough to practice lineouts
  - Availability of equipment to play basketball or indoor soccer

If these standards are not met, then the facility offered to the Visiting Union shall not be inferior to the facility available for use by the Host Union Team.

- 12.** The Visiting Union will be provided with exclusive access to the rugby pitch at their designated training ground at their agreed training times. Priority access will be provided to the Visiting Union for all other facilities at their designated training ground (including gymnasium, indoor facility and swimming pool). Visiting Unions must provide details of their finalised training schedule 24 hours prior to each training session in order that reasonable endeavours can be made to try to ensure that the facilities are closed to other users at this time.
- 13.** Commensurate with local medical practice, the Host Union and Visiting Union shall agree on the facilities, equipment, personnel (standby or otherwise) that will be available to the Visiting Union during training sessions and/or at training venues. These arrangements must be agreed no later than four weeks prior to the commencement of the International Tour.
- 14.** The Visiting Union acknowledges that the Host Union may have established a state of the art training facility (within its stadium or otherwise) which it is not possible to replicate in full and/or make available to the Visiting Union. The Visiting Union further acknowledges that provided the minimum facility and equipment requirements set out in this Schedule 5 are complied with by the Host Union then the Host Union shall be deemed to have fulfilled its obligations in relation to training, facility and equipment requirements notwithstanding the use by the Host Union of its training facility.

## **SCHEDULE 6. MINIMUM MEDICAL FACILITIES, EQUIPMENT AND PERSONNEL**

1. Prior to the commencement of the International Tour, the Host Union must provide details of Liaison Medical and Dental Officers and local medical facilities/contact details to facilitate smooth and accurate communication.
2. Where commensurate with local medical practice the following facilities, equipment and personnel should be provided and/or put in place:
  - (a) The Liaison Medical and Dental Officer should be available 24 hours each day of the Tour.
  - (b) At each Match Venue there should be a Match Doctor present to coordinate local medical cover.
  - (c) The facilities at the Match Venue should include an appropriate clean, well lit medical area for the examination, assessment and treatment of an injured Player.
  - (d) At the Match Venue there should be a full-length spinal board with body and head straps, a range of semi-rigid collars, a resuscitation kit and air splints for limb injuries.
  - (e) At the Match Venue there should be a fully trained paramedic ambulance crew, an orthopaedic surgeon and a clinician who can intubate and ventilate.
  - (f) Facilities, equipment and personnel that will allow a spinal injury/head injury to be stabilised, access to and availability of mechanical ventilation and transportation to a specialist centre within a reasonable time.
  - (g) For the purposes of the Training and Match Venues there must be an identified hospital facility for the transfer of injured Players.
  - (h) The Visiting Union should appoint Team Doctors who have appropriate sports injury knowledge and have certification in the management of emergencies on the field.

## SCHEDULE 7. DISPUTE RESOLUTION AND COMPLIANCE

1. Where a matter is referred to the Disputes Committee it will ordinarily be dealt with by a three person committee or single Judicial Officer. The Chairman of the Disputes Committee (or Judicial Officer as the case may be shall have experience in resolving commercial and Rugby disputes.
2. The Disputes Committee or Judicial Officer shall have the power to determine the following issues:
  - (a) Matters referred to it pursuant to Clause 25 of this Agreement.
  - (b) Adjudicating, in the case of dispute, on whether an event constitutes an Event of Force Majeure for the purposes of Clause 24 of this Agreement.
3. The Disputes Committee or Judicial Officer shall have full discretion as to its procedures (including any pre-hearing directions) and as to what evidence it may require. The Disputes Committee or Judicial Officer will not be bound by judicial rules governing procedure and/or admissibility of evidence provided that the proceedings are conducted with reasonable notice and in a fair manner with a reasonable opportunity for relevant parties to present their arguments always having due regard to the potential need to resolve disputes relating to the Agreement on an expedited basis.
4. The Disputes Committee or Judicial Officer shall be entitled to call on such experts (legal or otherwise) as it considers appropriate to assist in the matter under consideration.
5. The Disputes Committee or Judicial Officer will determine the timing of the hearing and the venue.
6. The Disputes Committee or Judicial Officer may deal with a case via written submissions and/or telephone and/or video conference and is not required to meet in person in order to determine any particular matter.
7. All hearings shall be held in private.
8. The Disputes Committee or Judicial Officer shall have the power to postpone or adjourn a hearing.
9. The Unions involved in the dispute proceedings shall have the right to be present and/or represented at any hearing or the Disputes Committee or Judicial Officer and shall be entitled through its nominated representative to make submissions.
10. The standard of proof on all questions to be determined by the Disputes Committee or Judicial Officer shall be the balance of probabilities.
11. The Disputes Committee or Judicial Officer shall be entitled to take such action and impose such penalties as it or he thinks fit in relation to any

dispute and/or established breach or the Tours Agreement, including but not limited to the following:

- (a) a caution, warning as to future conduct, reprimand and/or a fine;
  - (b) a suspension for a specified number of Matches and/or a specified period; a requirement that a Match or Matches be played with the exclusion of the public; the cancellation of a Match result and, where appropriate, the replaying of a Match; the forfeiture of a Match or Matches and/or ties(s); the deduction or cancellation of points; the immediate or future expulsion or suspension from a tournament(s) or competition(s); or any such similar sanctions, forfeiture of entitlement to host tours;
  - (c) a recommendation to the Council that a Union or Association be expelled or suspended from Membership of World Rugby. Only the Council shall be competent to expel or suspend a Union or Association and any such expulsion or suspension shall only have effect if approved by a two-thirds majority of the votes cast at a properly convened and quorate Council meeting;
  - (d) an order that any Union, Association, Rugby Body, Club or Person pay compensation and/or restitution;
  - (e) the withdrawal of other benefits or membership of World Rugby, including but not limited to, the right to apply to host International Tournaments; and
  - (f) any combination of the penalties set out above.
12. In determining the appropriate penalty under this Schedule 7, a Disputes Committee or Judicial Officer shall be entitled to take account of mitigating and/or aggravating circumstances.
13. Decisions of the Disputes Committee shall be made by majority.
14. The decisions of the Disputes Committee or Judicial Officer shall be binding immediately on notification to the Parties.
15. The decisions of the Disputes Committee or Judicial Officer may be published by World Rugby.
16. The Disputes Committee or the Judicial Officer shall be entitled to make such order as to costs as it considers/he considers appropriate.

### **Appeals**

17. Either Party may appeal the decision of the Disputes Committee or the Judicial Officer (or any part thereof).
18. To be valid, an appeal under these procedures must:

- (a) Be in writing and signed by either an authorised officer of the Union appealing or the Team Member that is appealing (as the case may be);
  - (b) Be received by the Appeal Panel Chairman, or his nominee, within forty eight (48) hours of the written decision being provided to the appealing party;
  - (c) Specify:
    - (i) the name of the appellant;
    - (ii) the decision appealed against;
    - (iii) the specific grounds of appeal.
- 19.** The appeal may be heard by an Appeal Committee or Appeal Officer. The Appeal Committee or the Appeal Officer adjudicating on an appeal hereunder shall have full discretion as to its procedures (including any pre-hearing directions) and as to what evidence it may require.
- 20.** The standard of proof on all questions to be determined in the appeal under these procedures shall be the balance of probabilities.
- 21.** The Appeal Committee or the Appeal Officer shall not be bound by judicial rules governing procedures and/or admissibility of evidence provided that the proceedings are conducted with reasonable notice in a fair manner with a reasonable opportunity for relevant parties to present their arguments always having due regard to the need to resolve the appeal on an expedited basis.
- 22.** The Appeal Committee or the Appeal Officer adjudicating on an appeal hereunder shall be entitled to call on such experts (legal or otherwise) as it or he considers appropriate to assist in the matter under consideration.
- 23.** The Appeal Committee or the Appeal Officer adjudicating on an appeal hereunder shall have power to conduct and regulate the appeal proceedings as it or he sees fit having regard to the circumstances of the case and shall be entitled to conduct a de novo hearing or hear the appeal based on the record of the decision of the Disputes Committee as it or he deems appropriate.
- 24.** The appellant may be represented by Legal Counsel.
- 25.** The Appeal Committee or the Appeal Officer adjudicating may deal with a case via written submissions and/or telephone and/or video conference and does not have to meet in person in order to determine any particular matter.
- 26.** All hearings shall be held in private.
- 27.** The Appeal Committee or the Appeal Officer adjudicating shall have power to postpone or adjourn a hearing.

- 
- 28.** Save where the Appeal Committee or the Appeal Officer adjudicating on an appeal hereunder decides to hear the entire case de novo, the appellant shall have the burden of proving that the decision being challenged should be overturned or varied.
- 29.** In exercising its or his jurisdiction, the Appeal Committee or the Appeal Officer adjudicating on the appeal hereunder shall have power to:
- (a) Dismiss the appeal;
  - (b) Quash, vary or increase any decision and/or penalty appealed against;
  - (c) Take any other steps that it considers necessary to deal justly with the appeal.
- 30.** The Appeal Committee or the Appeal Officer adjudicating on an appeal hereunder shall have the discretion to make such cost order as it or he deems appropriate.
- 31.** The decision on the appeal shall be advised to the parties as soon as practicable after the conclusion of the hearing and shall be final and binding on notification to the appellant.

[WORLD RUGBY.ORG](http://WORLD RUGBY.ORG)



**WORLD  
RUGBY™**